

Technical Report

**Description of a basic model of
the 'UpWind reference jacket' for code
comparison in the OC4 project under
IEA Wind Annex 30**

Authors

Dipl.-Ing. Fabian Vorpahl
MSc Wojciech Popko
Dipl.-Ing. Daniel Kaufer

July 19, 2013

Imprint

Fraunhofer Institute for Wind Energy and Energy System Technology IWES
Department of Turbine Simulation, Software Development and Aerodynamics
Am Seedeich 45
27572 Bremerhaven
Germany
www.fraunhofer.iwes.de

Contact:

Dipl.-Ing. Fabian Vorpahl
Tel: +49 471 14290-370
Email: fabian.vorpahl@iwes.fraunhofer.de

MSc Wojciech Popko
Tel: +49 471 14290-366
Email: wojciech.popko@iwes.fraunhofer.de

Dipl.-Ing. Daniel Kaufer
Tel: +49 711 68568-327
Email: daniel.kaufer@ifb.uni-stuttgart.de

July 19, 2013

Content

1	Introduction	3
2	Support structure model	5
2.1	Coordinate systems and definitions for joint and member identification	5
2.2	Jacket primary steel	7
2.3	Grouted connection	8
2.4	Transition piece	9
2.5	Tower	10
2.6	Rotor-nacelle assembly connection	11
2.7	Marine growth, appurtenances, free flooded members	11
	Bibliography	13
	Appendix	13
A	Node coordinates, property sets and members of jacket	14

Acknowledgements

The model described in this document is based on work jointly carried out by several participants in Work Package 4 'Offshore Support Structures and Foundations' of the UpWind project under the European Union's 6th Framework Programme¹. Contributions from the University of Stuttgart (T. Fischer), Delft University of Technology (W. de Vries), Garrad Hassan (T. Camp, A. Cordle), Germanischer Lloyd Wind (K. Argyriadis, B. Schmidt), Rambøll A/S (N. K. Vemula, P. Passon, H. Carstens), NREL (J. Jonkman) are kindly acknowledged. Further refinements of the model have been discussed in the working group of the IEA Wind Annex 30 Offshore Code Comparison Collaboration Continuation (OC4) project². Special support from M. Muskulus from the Norwegian University of Science and Technology and H. von Waaden from REpower systems AG is very appreciated.

¹www.upwind.eu

²www.ieawind.org/task_30/task30_Public.html

1 Introduction

This document describes the jacket support structure model to be used in Phase I of the OC4 project. The jacket was originally designed by Rambøll A/S (Vemula, 2010) in the UpWind project. The turbine, which is to be used with this jacket structure is the well known 'NREL 5-MW baseline turbine' (Jonkman et al., 2009).

The support structure model is described in the following, no further information concerning structural properties is necessary to run the simulations in the course of this project¹. For the turbine model, i.e. the rotor-nacelle assembly (RNA) as the tower is mentioned as part of the support structure in the following, it is referred to Jonkman et al. (2009). There is one difference compared to the original description of the tower. The hub height of the turbine is shifted from 90 m to 90.55 m with the jacket due to a shifted tower top elevation.

The term offshore wind turbine (OWT) denotes the system as a whole, RNA and support structure, in this document.

This section is meant to give a general overview of the jacket support structure as it was designed by Rambøll A/S for the UpWind project. A detailed description of the numerical model of this structure for OC4 is given in Section 2.

The support structure described herein is designed for the 5-MW baseline turbine at the UpWind deep water reference site (Fischer et al., 2010) in 50 m of water. The four legged jacket has four levels of X-braces, accordingly mud braces and four central piles with a penetration depth of 45 m. Piles are grouted to the jacket legs. The transition piece (TP) between the jacket and the tower is a block of concrete that is penetrated by the upper parts of the four jacket legs. The total height of the jacket from mudline including the TP and excluding the tower is 70.15 m. The conical tower has a total length of 68 m leading to a realistic hub height over the mean sea level (MSL) of 90.55 m. Figure 1.1 shows the complete support structure.

¹An interested reader may find further details on the jacket and the design process in Vemula (2010)

Figure 1.1
Jacket with tower
and piles
(middle), concrete TP
(right) and pile heads
in detail (left).

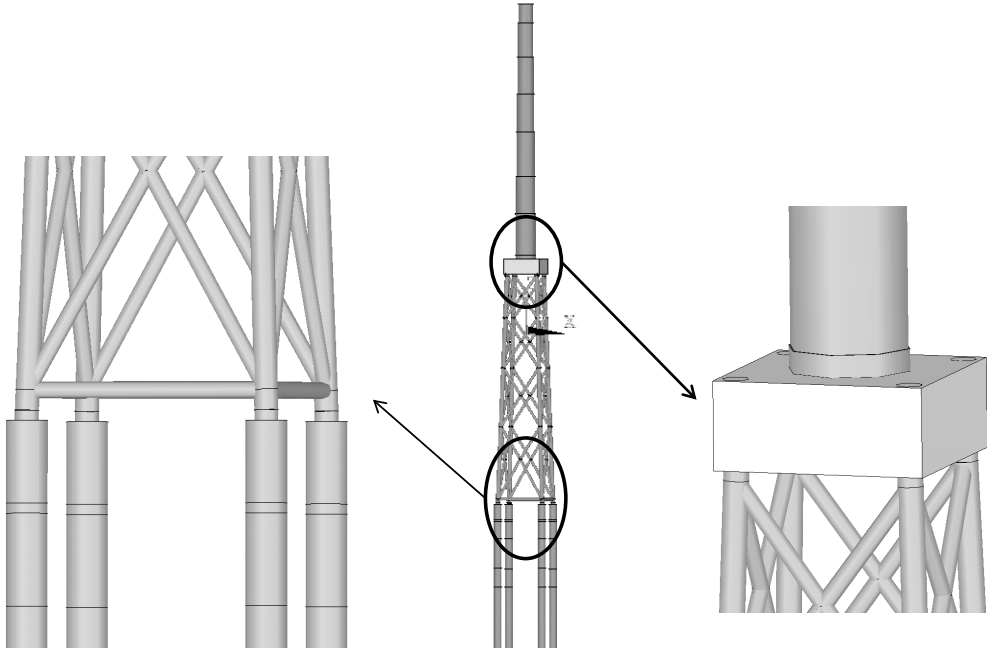

2 Support structure model

In this section, a basic numerical model of the jacket support structure carrying the NREL 5-MW baseline RNA for the aero-hydro-servo-elastic simulation in the OC4 project is described. This model is meant to be a common starting point. Further refinements may be realized in the course of the project. The assumed steel properties, such as density, Young's modulus and Poisson's ratio are as follows for the whole structural model:

$$\rho_s = 7850 \text{ kg/m}^3 \quad E_s = 2.1 \text{E}11 \text{ N/m}^2 \quad \nu_s = 0.3$$

The critical structural-damping ratio ζ_s and the corresponding logarithmic decrement δ_s for all modes of the support structure (without the rotor-nacelle assembly mass present) are defined as :

$$\zeta_s = 1 \% \quad \delta_s = 6 \%$$

This corresponds to the values defined by Kooijman et al. (2003) that were used in Jonkman et al. (2009) for the steel tower.

Node coordinates and member properties of the jacket are given in Appendix A including the pile sections above mudline. For the grout connection between piles and legs, for the TP and for the tower, the properties are not included in Appendix as these might be modeled differently in different simulation systems. For those parts, all necessary assumptions for a proper modeling are given in Sections 2.3, 2.4 and 2.5, respectively. Section 2.7 provides supplementary information necessary for proper modeling and simulation of the jacket.

2.1 Coordinate systems and definitions for joint and member identification

The x-axis of the global Cartesian coordinate system points downwind with respect to the main wind direction. The z-axis points upwards. The y-axis forms a right hand system. The origin lies at the mean sea level (MSL) in the centerline of the

tower. Mean wind and wave directions are aligned and the jacket is positioned with its sides (top view) parallel to the x- and y-axis, respectively.

Table 2.1 defines position of members and joints of the jacket.

Table 2.1
Description of jacket joints, members and their positions.

Description	Name	Position
jacket leg 1	L1	$x > 0; y > 0$
jacket leg 2	L2	$x < 0; y > 0$
jacket leg 3	L3	$x < 0; y < 0$
jacket leg 4	L4	$x > 0; y < 0$
jacket side 1	S1	leg 1 to leg 2
jacket side 2	S2	leg 2 to leg 3
jacket side 3	S3	leg 3 to leg 4
jacket side 4	S4	leg 4 to leg 1
intersection level at upper Y-Joints	YUp	$z = 15.615 \text{ m}$
intersection level at highest X-Joints	X1	$z = 10.262 \text{ m}$
intersection level at 2 X-Joints	X2	$z = -1.958 \text{ m}$
intersection level at 3 X-Joints	X3	$z = -16.371 \text{ m}$
intersection level at 4 X-Joints	X4	$z = -33.373 \text{ m}$
intersection level at highest K-Joints	K1	$z = 4.378 \text{ m}$
intersection level at middle K-Joints	K2	$z = -8.922 \text{ m}$
intersection level at lower K-Joints	K3	$z = -24.614 \text{ m}$
intersection level at lower Y-Joints	YBottom	$z = -43.127 \text{ m}$
intersection level at mud brace	mud brace	$z = -44.001 \text{ m}$

Figure 2.1 shows the global coordinates, the mean wind and wave directions and the definitions given in Table 2.1. As an example, Joint 'K2L1' identifies the double K-Joint at the middle K-joint level ($z = -8.922 \text{ m}$) being part of Leg 1. These definitions allow for the clear identification of braces as well, here, the information about the side must be included. As this becomes difficult to manage, the 64 braces are numbered top-down, from Leg 1 to Leg 4 with increasing leg number (counter clockwise for top view) as indicated in Figure 2.1 as well (bottom right) additionally.

The local member coordinate systems are defined as follows: the origin of each coordinate system lies between the two nodes in the center of the member. The local x-axis points from the node with the lower number to the node with the higher number along the member axis (cf. node numbering given in Appendix A). The local z-axis is perpendicular to a plane defined by the global x-axis and the member axis. There is one exception of this definition: with a member axis parallel to the global x-axis, this plane definition is impossible. In this case, the local z-axis is parallel to the global y-axis. The local y-axis is defined to form the right handed Cartesian coordinate system.

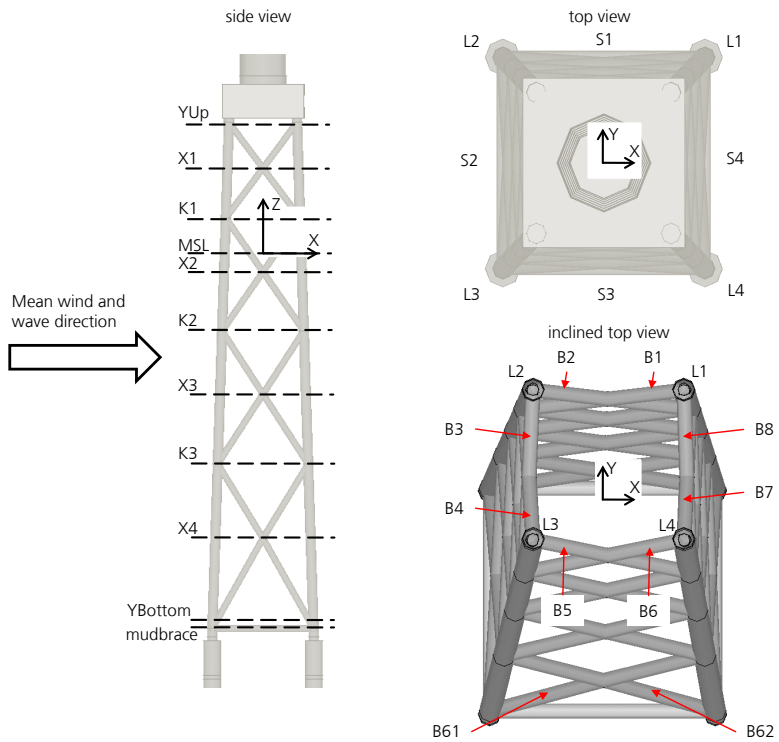
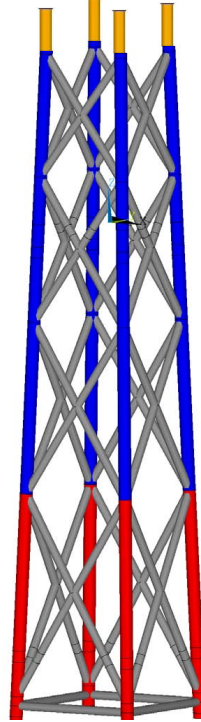

Figure 2.1
Global coordinate system, mean sea level (MSL), mean wind- and wave directions and definitions given in Table 2.1 (left). Jacket top view (upper, right) and inclined top view (lower, right) to clarify Joint, leg and brace naming conventions.

2.2 Primary steel jacket

Nodes, members and properties of the jacket model defined in the global Cartesian system as described in Section 2.1 are given in Appendix A.

Figure 2.2
Jacket as described
in Appendix A.
Member properties
displayed as given in
Table 2.2.



The properties of the tubular members are shown as described in Table 2.2. The table gives the property set number describing the geometry of the component, the name of each of those components, its color in Figure 2.2 and the properties outer diameter and wall thickness.

Table 2.2
Property sets of
jacket members.

Property set	Component	Color in Figure 2.2	Outer diameter [m]	Thickness [mm]
1	x- and mud braces	grey	0.8	20
2	leg at lowest level	red	1.2	50
3	leg 2 to 4 level	blue	1.2	35
4	leg crossing TP	orange	1.2	40
5	pile	not shown	2.082	60

2.3 Grouted connection

In this basic model, the structure is cantilevered at mudline. Meaning that all six degrees of freedom are set to zero at those positions. Therefore only the part of the piles over mudline is included in the model. These parts are mentioned as part of the jacket in the following. They consist basically of two tubular members,

the pile and the jacket leg that are connected with a grout material at each jacket corner. Figure 2.3 shows this part of the structure in detail.

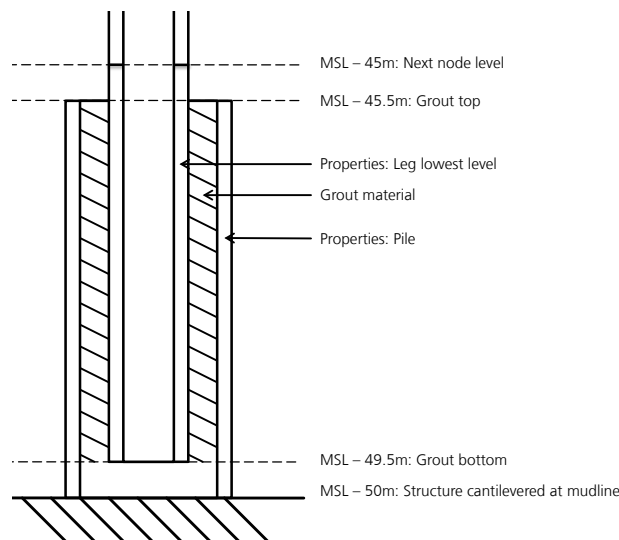

Figure 2.3
Grouted leg pile connection. The coordinates given with respect to MSL. The properties of the steel members are defined in Table 2.2.

As described in this figure in global coordinates (cf. Section 2.1), mudline lies at $z = -50$ m. The bottom of the grouted connection at $z = -49.5$ m and the upper end of the grout lies at $z = -45.5$ m. At $z = -45$ m the next level of structural nodes is found as defined in Appendix A at $z = -45$ m. The properties of the leg at lowest level and the pile are given in Table 2.2.

The density of the grout material between the two steel parts is $\rho_G = 2000 \text{ kg/m}^3$. As the stiffness of the two steel members together with the grout material is very high, the grouted volume from MSL -49.5 m to MSL -45 m (pile and leg and grout) is assumed to be rigid in the model.

2.4 Transition piece

A TP is a rigid concrete block with a mass of 666 t and a size of $4 \times 9.6 \times 9.6$ m. It is positioned on top of the jacket with its center in the centerline of the tower, as shown in Figure 2.4. The four supplementary vertical steel members that are grouted into the concrete, are parts of the jacket legs and therefore mentioned as part of the jacket in the context of this project. At $z = 15.651$ m the legs and the braces at the highest level (cf. Table 2.1; YUp) intersect and the lower end of the TP lies at $z = 16.15$ m. The upper end of the TP and the connection to the tower

lies at $z = 20.15$ m. The following member from $z = 20.15$ m to $z = 21.15$ m is mentioned as part of the tower.

Figure 2.4
TP coordinates are given with respect to MSL. Properties of the vertical steel members are given in Table 2.2.

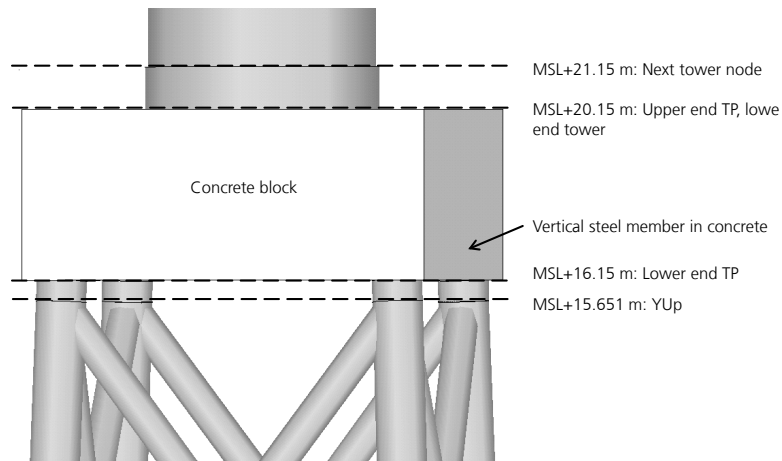

2.5 Tower

As shown in Figure 2.4, the connection between TP and tower lies at MSL + 20.15 m. The diameter of the conical tower decreases with height, the wall thickness as well. Only in the very upper part of tower the thickness is re-increased. The tower properties are given in terms of values at cross sections herein. In Table 2.3, the z-coordinate in the global coordinate system (with respect to MSL), and the outer diameter and thickness are provided. Three point masses representing flanges, bolts and equipment installed in the tower are included in the model. The point masses are positioned at the vertical tower centerline, the height coordinates and the masses are given in Table 2.3.

Table 2.3
Tower cross sectional properties:
z-coordinate with respect to MSL, outer diameter, thickness and point masses representing masses of flanges bolts and installed equipment.

Global height z [m]	Outer diameter [m]	Thickness [mm]	Point mass [t]
20.15	5.600	32	1.9
21.15	5.577	32	No
32.15	5.318	30	No
42.15	5.082	28	No
54.15	4.800	24	1.4
64.15	4.565	22	No
74.15	4.329	20	No
83.15	4.118	30	No
88.15	4.000	30	1.0

2.6 Rotor-nacelle assembly connection

The RNA and the support structure described herein include all properties of the OWT to be used in this project. The highest tower node defined in Table 2.3 represents the yaw bearing. The elevation of the yaw bearing is $z = 87.6$ m above MSL (Jonkman et al., 2009, p.13) and the corresponding value defined herein is $z = 88.15$ m over MSL. As all other distances provided by Jonkman are kept the same, the hub height of the OC4 model is $z = 90.55$ m and *not* $z = 90$ m. Figure 2.5 shows the RNA to be used here based on the description in Jonkman et al. (2009) (values from Table 1-1 on p. 2 and Table 4-1 on p. 13 included). The elevation of the yaw bearing in the global coordinate system (the only value that has been modified) is marked in red. If there is a supplementary member to be defined in certain simulation systems to connect the tower top to the RNA, this should be modeled rigid and massless.

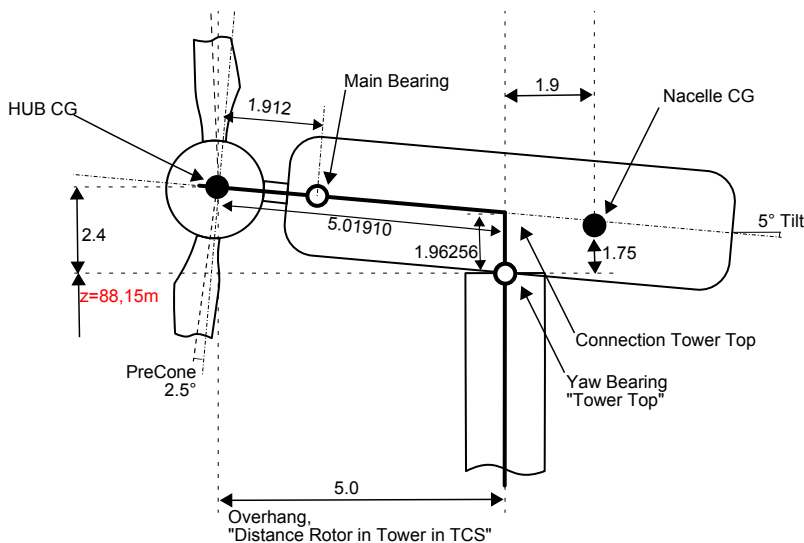

Figure 2.5
RNA to be used in this project based on the definitions given in Jonkman et al. (2009). Only the yaw bearing elevation (red) was changed from $z = 87.6$ m to $z = 88.15$ m.

2.7 Marine growth, appurtenances, free flooded members

As marine growth may influence the loads and the dynamic behavior, namely the eigenstates of a jacket structure significantly, it is included in the model described herein as recommended by the respective guidelines i.e. DNV (2011) and given by Fischer and Kühn (2009). Table 2.4 shows the depth range with respect to MSL to apply marine growth, its thickness and density.

Table 2.4
Marine growth in the
jacket model.

Depth range	$-40 \text{ m} \leq z_g \leq -2 \text{ m}$
Thickness	$t_g = 100 \text{ mm}$
Density	$\rho_g = 1100 \text{ kg/m}^3$

Appurtenances on the jacket structure such as boat landings, J-tubes, anodes, cables, ladders etc. are not included in the model. The legs of the jacket structure are assumed to be free flooded by sea water with a density of $\rho_w = 1025 \text{ kg/m}^3$, the braces are not.

Bibliography

- DNV (2011). *DNV-OS-J101 Design of Offshore Wind Turbine Structures*. Det Norske Veritas A/S.
- Fischer, T. and Kühn, M. (2009). Site Sensitive Support Structure and Machine Design for Offshore Wind Farms. *EWEC 2009 conference proceedings*, Marseille.
- Fischer, T., Vries, W. d., and Schmidt, B. (2010). UpWind Design Basis (WP4: Offshore Foundations and Support Structures). Technical report, Endowed Chair of Wind Energy (SWE) at the Institute of Aircraft Design, University of Stuttgart, Stuttgart.
- Jonkman, J., Butterfield, S., Musial, W., and Scott, G. (2009). Definition of a 5-MW Reference Wind Turbine for Offshore System Development. Technical Report NREL/TP-500-38060, National Renewable Energy Laboratory, Golden, CO.
- Kooijman, H. J. T., Lindenburg, C., Winkelaar, D., and van der Hooft, E. L. (2003). DOWEC 6 MW PRE-DESIGN: Aero-elastic Modelling of the DOWEC 6 MW Pre-design in PHATAS. Technical report, ECN.
- Vemula, N. K. (2010). Design Solution for the UpWind Reference Offshore Support Structure – Deliverable D4.2.5 (WP4: Offshore Foundations and Support Structures). Technical report, Rambøll Wind Energy, Esbjerg.

A Node coordinates, property sets and members of jacket

For the grout connection between piles and legs, for the TP and for the tower, the properties are *not* included in this Appendix, as these might be modeled differently in different simulation systems. For those parts, all necessary assumptions for a proper modeling are given in Sections 2.3, 2.4 and 2.5, respectively.

Table A.1
Nodal coordinates.

Node	x [m]	y [m]	z [m]	node	x [m]	y [m]	z [m]
1	6	6	-45.50	30	-4.385	-4.385	4.378
2	6	6	-45	31	-4.016	-4.016	15.651
3	5.967	5.967	-44.001	32	-4	-4	16.15
4	5.939	5.939	-43.127	33	4.82	-4.82	-8.922
5	5.333	5.333	-24.614	34	4.385	-4.385	4.378
6	-6	6	-45.50	35	4.016	-4.016	15.651
7	-6	6	-45	36	4	-4	16.15
8	-5.967	5.967	-44.001	41	5.62	0	-33.373
9	-5.939	5.939	-43.127	42	-5.62	0	-33.373
10	-5.333	5.333	-24.614	43	0	5.62	-33.373
11	-6	-6	-45.50	44	0	-5.62	-33.373
12	-6	-6	-45	45	5.064	0	-16.371
13	-5.967	-5.967	-44.001	46	-5.064	0	-16.371
14	-5.939	-5.939	-43.127	47	0	5.064	-16.371
15	-5.333	-5.333	-24.614	48	0	-5.064	-16.371
16	6	-6	-45.50	49	4.592	0	-1.958
17	6	-6	-45	53	-4.592	0	-1.958
18	5.967	-5.967	-44.001	51	0	4.592	-1.958
19	5.939	-5.939	-43.127	52	0	-4.592	-1.958
20	5.333	-5.333	-24.614	53	4.193	0	10.262
21	4.82	4.82	-8.922	54	-4.193	0	10.262
22	4.385	4.385	4.378	55	0	4.193	10.262
23	4.016	4.016	15.651	56	0	-4.193	10.262
24	4	4	16.15	57	4	4	20.15
25	-4.82	4.82	-8.922	58	-4	4	20.15
26	-4.385	4.385	4.378	59	4	-4	20.15
27	-4.016	4.016	15.651	60	-4	-4	20.15
28	-4	4	16.15				
29	-4.82	-4.82	-8.922				

Table A.2
Member properties.

Property set	Outer diameter [m]	Wall thickness[m]
1	0.8	0.20E-01
2	1.2	0.50E-01
3	1.2	0.35E-01
4	1.2	0.40E-01

Appendix

Member	Node 1	Node 2	Property set	Member	Node 1	Node 2	Property set
1	1	2	2	57	5	45	1
2	2	3	2	58	45	33	1
3	3	4	2	59	20	45	1
4	4	5	2	60	45	21	1
5	6	7	2	61	10	46	1
6	7	8	2	62	46	29	1
7	8	9	2	63	15	46	1
8	9	10	2	64	46	25	1
9	11	12	2	65	5	47	1
10	12	13	2	66	47	25	1
11	13	14	2	67	10	47	1
12	14	15	2	68	47	21	1
13	16	17	2	69	20	48	1
14	17	18	2	70	48	29	1
15	18	19	2	71	15	48	1
16	19	20	2	72	48	33	1
17	5	21	3	73	21	49	1
18	21	22	3	74	49	34	1
19	22	23	3	75	33	49	1
20	23	24	3	76	49	22	1
21	10	25	3	77	25	50	1
22	25	26	3	78	50	30	1
23	26	27	3	79	29	50	1
24	27	28	3	80	50	26	1
25	15	29	3	81	21	51	1
26	29	30	3	82	51	26	1
27	30	31	3	83	25	51	1
28	31	32	3	84	51	22	1
29	20	33	3	85	33	52	1
30	33	34	3	86	52	30	1
31	34	35	3	87	29	52	1
32	35	36	3	88	52	34	1
37	3	8	1	89	22	53	1
38	8	13	1	90	53	35	1
39	13	18	1	91	34	53	1
40	18	3	1	92	53	23	1
41	4	41	1	93	26	54	1
42	41	20	1	94	54	31	1
43	19	41	1	95	30	54	1
44	41	5	1	96	54	27	1
45	9	42	1	97	22	55	1
46	42	15	1	98	55	27	1
47	14	42	1	99	26	55	1
48	42	10	1	100	55	23	1
49	4	43	1	101	34	56	1
50	43	10	1	102	56	31	1
51	9	43	1	103	30	56	1
52	43	5	1	104	56	35	1
53	19	44	1	105	24	57	4
54	44	15	1	106	28	58	4
55	14	44	1	107	32	60	4
56	44	20	1	108	36	59	4

Table A.3
Members.