



**KERNFORSCHUNGSANLAGE JÜLICH GmbH**

Projektleitung Energieforschung  
International Energy Agency IEA

**Implementing Agreement for  
Co-Operation in the Development  
of Large Scale  
Wind Energy Conversion Systems**

**9<sup>th</sup> Meeting of Experts- Structural Design Criteria  
for LS WECS**

Organised by:  
Project Management for Energy Research (PLE)  
of the Nuclear Research Establishment Jülich (KFA)  
on behalf of the  
Federal Minister of Research and Technology,  
the Fluid Mechanics Department  
of the Technical University of Denmark  
and the Wind Energy Group, Southhall

**Jül - Spez - 225**

**October 1983**

ISSN 0343-7639

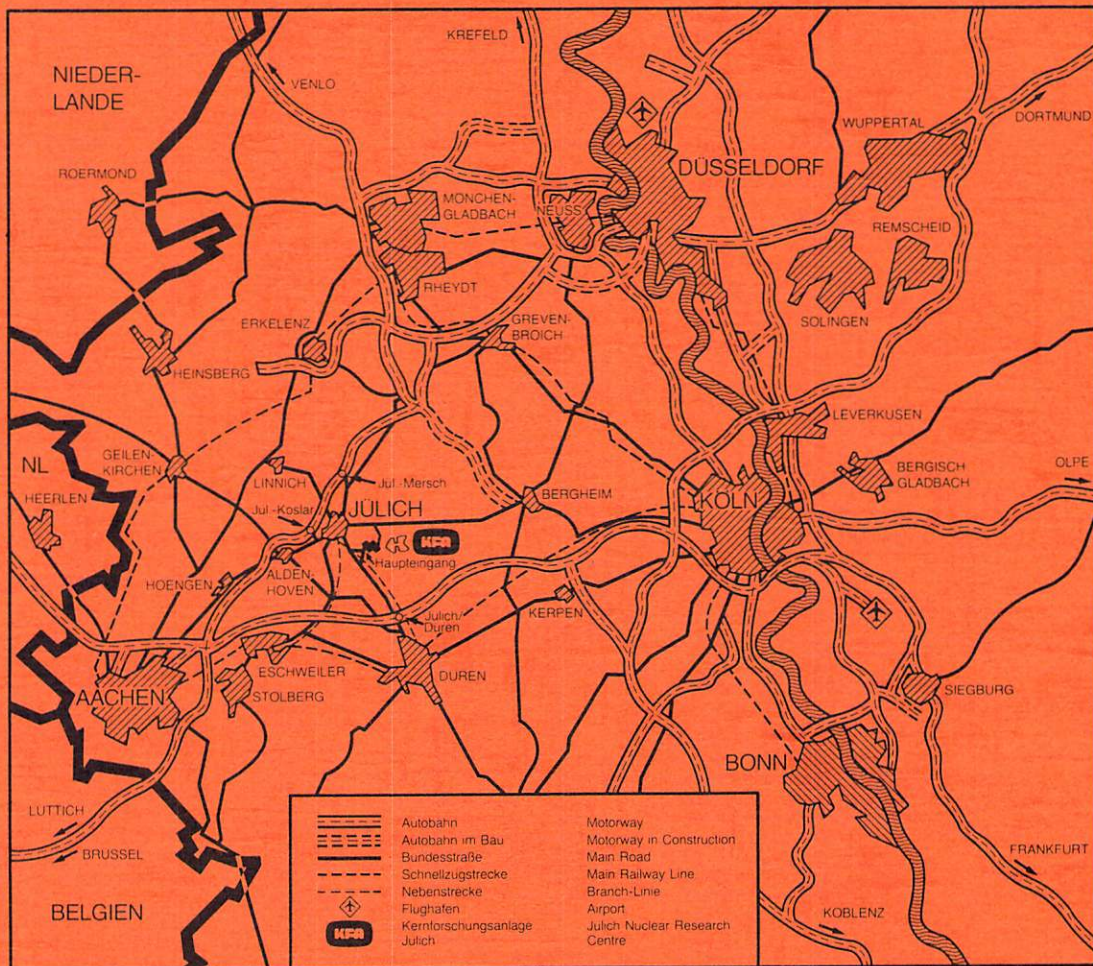

Als Manuskript gedruckt

**Spezielle Berichte der Kernforschungsanlage Jülich – Nr. 225**

Projektleitung Energieforschung Jül - Spez - 225

Zu beziehen durch: ZENTRALBIBLIOTHEK der Kernforschungsanlage Jülich GmbH  
 Postfach 1913 · D-5170 Jülich (Bundesrepublik Deutschland)  
 Telefon: 02461/610 · Telex: 833556-0 kf d

# **Implementing Agreement for Co-Operation in the Development of Large Scale Wind Energy Conversion Systems**

**9<sup>th</sup> Meeting of Experts- Structural Design Criteria  
for LS WECS**

**Greenford, March 7-8, 1983**

Organised by:

Project Management for Energy Research (PLE)  
of the Nuclear Research Establishment Jülich (KFA)  
on behalf of the  
Federal Minister of Research and Technology,  
the Fluid Mechanics Department  
of the Technical University of Denmark  
and the Wind Energy Group, Southhall

Scientific Coordination:

L. Möller (PLE-KFA Jülich)  
M. Petersen (Techn. Univ. of Denmark)  
P. Simpson (Wind Energy Group, Southhall)  
R. Windheim (PLE-KFA Jülich)

# C O N T E N T S

-----

	<u>Page</u>
P. SIMPSON (Wind Energy Group, UK) Structural loading criteria for Large Scale WECS Preamble .....	1
R.W. THRESHER and W.E. HOLLEY (Oregon State University, USA) Wind turbine structural response due to wind turbulence .....	5
P. HAUGE MADSON (Risø, Denmark) Dynamic analysis of wind turbine rotors for lifetime prediction .....	27
M.B. ANDERSON (sir Robert McAlpine & Sons Ltd., UK), A.D. GARRAD and U. HASSAN (Wind Energy Group, UK) Teeter excursions of a 2 bladed horizontal axis wind turbine ..	53
A.D. GARRAD and U. HASSAN (Wind Energy Group, UK) Turbulence induced loads in a Wind turbine rotor .....	89
B. MONTGOMERIE (FFA, Sweden) Some aspects of the structural loading criteria applied to the Swedish megawatt wind turbines .....	109
G. HUSS and E. HAU (M.A.N., Germany) Load cases for the structural design of GROWIAN and some signi- ficant results of the load calculations .....	111
B. DAHLROTH (VAST, Sweden) Load cases for medium sized wind power plants .....	121
S. HOLT (Central Electricity Research Laboratories, UK) and D.J. MILBORROW (CEBG, UK) Rotor blade loads on horizontal and vertical axis wind turbines .....	195
I.P. FICENCE (WEI Cranes Ltd., UK) Transmission dynamics of vertical axis variable geometry wind turbines .....	201
List of participants, map, previous expert meetings .....	217

## IEA LS WECS

Preamble to Expert Meeting  
onStructural Loading Criteria for Large Scale WECS

Peter Simpson

1. Introduction

This paper serves to identify some of the questions which arise in the formulation of structural loading criteria for the design of large scale Wind Energy Conversion Systems. It is not comprehensive, but concentrates on some aspects of the loads on WECS which on account of their unusual or, in some cases, complex nature are of particular interest to designers, analysts and meteorologists who jointly are concerned with formulating design rules which, as well as being safe, permit the construction of machines which will provide the most economic means of converting wind energy to useful power.

2. Complex Loadings

Descriptions of the periodic loadings on the rotor of an operating Wind Energy Converter due to influences such as yaw angle, wind shear and tower shadow are relatively straight forward. The loadings on a stationary WEC also present few problems as they can in principle be calculated using methods which are well established for a variety of fixed structures, either rigid or flexible.

Most of the difficulties associated with providing satisfactory descriptions of loads on WECS relate either to turbulence in the air stream intercepted by the rotor or the rapidly changing and sometimes complex successions of events that can occur during start-up and shut-down sequences.

3. Turbulence

Methods for analysing the response of a straight slender structure to turbulence in the wind are quite well documented. The influence of the rotation of a WEC rotor on the response of the system to turbulence, however, requires special treatment. The results of theoretical analyses and correlation with results from testing of systems in operation are particularly relevant to establishing accurate loading criteria.

The following are some of the questions which arise:

- a) How important is turbulent loading when compared with the quasi-steady periodic loadings associated with yaw, shear, etc?
- b) Can discrete gusts be used satisfactorily to simulate turbulent loading?
- c) Is three dimensional turbulence important?
- d) Is the present level of aerodynamic modelling adequate to deal with unsteady turbulent loads?
- e) For fixed pitch (horizontal axis) machines does the turbulence in the separated flow dominate the meteorological contribution?
- f) Existing models apply only to isolated machines, what happens to the ambient spectrum for clusters of machines?

#### 4. Start-up and Shut-down Sequences

Almost all start sequences can be described as normal, whereas shut-down sequences may be normal or associated with system faults.

All start-up and shut-down sequences present some difficulties with respect to the definition of loadings, insofar as they comprise a succession of operating conditions, each in combination with a variety of possible wind conditions. Particular cases of shut-down sequences associated with fault conditions demand careful analysis as they will probably give rise to extreme loadings. The statistical treatment of combinations of wind speed with system malfunction and particular control sequences may then require careful consideration in order to avoid oversight, on the one hand, or undue conservatism, on the other.

Here, the following questions arise:

- a) Typically, what proportion of the total fatigue loading on various components occurs during start-up and shut-down sequences.
- b) To what extent can careful control strategies reduce loadings, both extreme and fatigue, during these sequences.

#### 5. Further Considerations of Particular Importance

In addition to the aspects of WECS loading already mentioned, the following may be considered to be of particular importance in a

discussion of structural loading criteria:

- a) Prediction of extreme winds, especially in combination with infrequent system status (such as parking with fault condition) in order to design for appropriate probabilities of serviceable survival.
- b) Safeguards against extremely improbable failure modes e.g. blade (tip) loss.

## WIND TURBINE STRUCTURAL RESPONSE DUE TO WIND TURBULENCE

R. W. Thresher

W. E. Holley

Mechanical Engineering Department

Oregon State University

Corvallis, Oregon 97331

Presented at the IEA Expert Meeting  
"Structural Loading for Large Scale WECS"  
March 7-8, 1983

Held at Taylor Woodrow Construction Ltd.  
309 Ruislip Road East  
Greenford, Middlesex, England UB6 9BQ

## ABSTRACT

This paper presents some approaches to modeling the dynamic response of wind turbine systems to atmospheric turbulence. The first section deals with one possible method for modeling the wind turbulence inputs. The second section looks at the machine response to the turbulence, and shows why the resulting loads should be computed using a coupled dynamic model. The third section examines some of the problems encountered when estimating the fatigue life of a turbine exposed to random atmospheric excitations. In the final section, some suggestions are made for alternate approaches to modeling the effects of turbulence on wind systems.

## THE WIND INPUT

It was the goal of the research work at Oregon State University to develop a method for computing the effect of atmospheric turbulence excitations which treated the wind input and the turbine response using the statistical techniques of random vibration theory, and avoid the artificial concept of a discrete deterministic wind gust. A complete statistical description of the turbulent wind field over the rotor disk was computationally impossible, so simplifying assumptions were made. A model was developed that preserved many of the physical pro-



properties which were known to cause dynamic response of wind turbines, but was computational simple and could be used in either the frequency domain or the time domain. The turbulence field at the rotor disk is approximated with a set of velocity components which are uniform over the rotor disk, and a set of six velocity gradients across the disk. Thus, the model includes all three velocity components, and allows for both horizontal and vertical wind shears in each velocity component. The wind inputs can thus be written as

$$(1) \quad \{V_{\infty}\} = \begin{Bmatrix} 0 \\ V_w \\ 0 \end{Bmatrix} + \begin{Bmatrix} V_x \\ V_y \\ V_z \end{Bmatrix} + \begin{bmatrix} V_{x,x} & V_{x,y} & V_{x,z} \\ V_{y,x} & V_{y,y} & V_{y,z} \\ V_{z,x} & V_{z,y} & V_{z,z} \end{bmatrix} \begin{Bmatrix} r \sin \Omega t \\ 0 \\ r \cos \Omega t \end{Bmatrix}$$

where the mean wind is in the y direction, the commas imply differentiation with respect to the coordinate of the following subscript, and the uniform velocity terms,  $V_i$ , and the linear gradient terms,  $V_{i,j}$ , are functions of time.

In order to simplify the correlation model, and because certain combinations of the gradient terms in the plane of the rotor always appear together in the linearized aerodynamic relationships, the following quantities are defined.

$$(2) \quad \begin{aligned} \gamma_{zx} &= \frac{1}{2} (V_{z,x} - V_{x,z}), & \bar{\gamma}_{zx} &= \frac{1}{2} (V_{z,x} + V_{x,z}) \\ \epsilon_{zx} &= \frac{1}{2} (V_{z,z} - V_{x,x}), & \bar{\epsilon}_{zx} &= \frac{1}{2} (V_{z,z} + V_{x,x}) \end{aligned}$$

Then the turbulent velocity at the rotor can be rewritten as

$$(3) \left\{ \begin{matrix} V_x \\ V_y \\ V_z \end{matrix} \right\} = \left\{ \begin{matrix} V_x + (\bar{\epsilon}_{zx} - \epsilon_{zx}) r \sin\Omega t + (\bar{\gamma}_{zx} - \gamma_{zx}) r \cos\Omega t \\ V_w + V_y + V_{y,x} r \sin\Omega t + V_{y,z} r \cos\Omega t \\ V_z + (\bar{\gamma}_{zx} + \gamma_{zx}) r \sin\Omega t + (\bar{\epsilon}_{zx} + \epsilon_{zx}) r \cos\Omega t \end{matrix} \right\}$$

where the nine turbulence inputs:  $V_x, V_y, V_z, V_{y,x}, V_{y,z}$  and  $\gamma_{zx}, \epsilon_{zx}, \bar{\gamma}_{zx}, \bar{\epsilon}_{zx}$  vary with time and can be shown to be statistically uncorrelated.

A correlation model for the various velocity components is derived using the Von Karman isotropic turbulence model to obtain the correlation between velocities at spatially separated points. Using this correlation model for the turbulence field, the velocity at the rotor disk is approximated by the time dependent uniform and gradient terms of Eq. (2). These terms are chosen to minimize the expected error between the true velocity and the approximate velocity over a region the size of the rotor disk. Furthermore, the power spectral densities are approximated by a simple rational form which corresponds to an exponentially correlated random process, and can be easily used analytically, or for time domain simulations. This model is conveniently expressed by the stochastic differential equation

$$(4) \quad \dot{u} + \hat{a}u = \hat{b}w$$

where  $u$  = instantaneous value of one of the terms  $V_x, \dots, V_{y,x}, \dots, \gamma_{xz}$ , etc.  
 $w$  = nondimensional white noise with power spectral density  $S_w = \sigma^2 L / V_w^3$   
 $\hat{a}$  =  $\frac{V_w}{L} a_*$

$$\hat{b} = \begin{cases} \frac{V_w^2}{L} b_* & \text{for uniform terms} \\ \frac{V_w^2}{LR} b_* & \text{for gradient terms} \end{cases}$$

$\sigma^2$  = turbulent velocity component variance  
 $L$  = turbulence integral scale  
 $V_w$  = mean wind speed  
 $R$  = rotor disk radius

where the nondimensional coefficients  $a_*$  and  $b_*$  are tabulated for a wide variety of turbine size to length scale ratios,  $(R/L)$ . A detail development of this model, as well as, some typical results have been documented in references (1,2).

At this time, work is underway to improve this wind model by adding terms which allow for a quadratic variation in the longitudinal component of the turbulence. This effort is to be completed in September, 1982.

#### THE TURBINE RESPONSE

The wind turbine model is shown schematically in Figure 1. Both the rotor and the nacelle are assumed to be rigid bodies which move in unison, except for the spinning rotor. Due to tower flexibility, the nacelle and rotor are free to translate in a plane parallel to the ground and rotate about the top of the tower in pitch and yaw. The yaw angle of the rotor axis is defined by the angle,  $\phi$ , and the pitch angle by  $\chi$ . The lateral translation,  $U$ , is in the  $x$  direction, while the  $V$  translation is in the  $y$  direction along the rotor axis. The rotor spin velocity is given by  $\Omega + \dot{\Psi}$ , where  $\Omega$  is the mean rotation rate and  $\dot{\Psi}$  is some small fluctuation. For the case of a turbine with a three-bladed rigid rotor, the basic principles of Newtonian mechanics and linear, quasi-steady aerodynamics give motion equations of the form

Table 1. Wind Model Assumptions and Important Features

- 
1. The velocity components are correlated using the Von Karman isotropic turbulence model.
  2. The turbulent velocity field at the rotor disk is approximated using three uniform terms plus six gradient terms.
  3. Each of these nine turbulence inputs is modeled as a stationary, exponentially correlated random process, which can be represented by a first order linear differential equation.
  4. Velocity shears caused by turbulence seem to result in significant turbine response and are modeled for all the velocity components.
  5. Three wind parameters are required to model a specific site: the mean wind, the turbulent velocity component variance, and the turbulence length scale.
  6. The model can be used to perform analysis in the frequency domain, as was done for the results which will be presented here, or the differential equations of the wind model can be used to drive any type of time domain simulation.
-

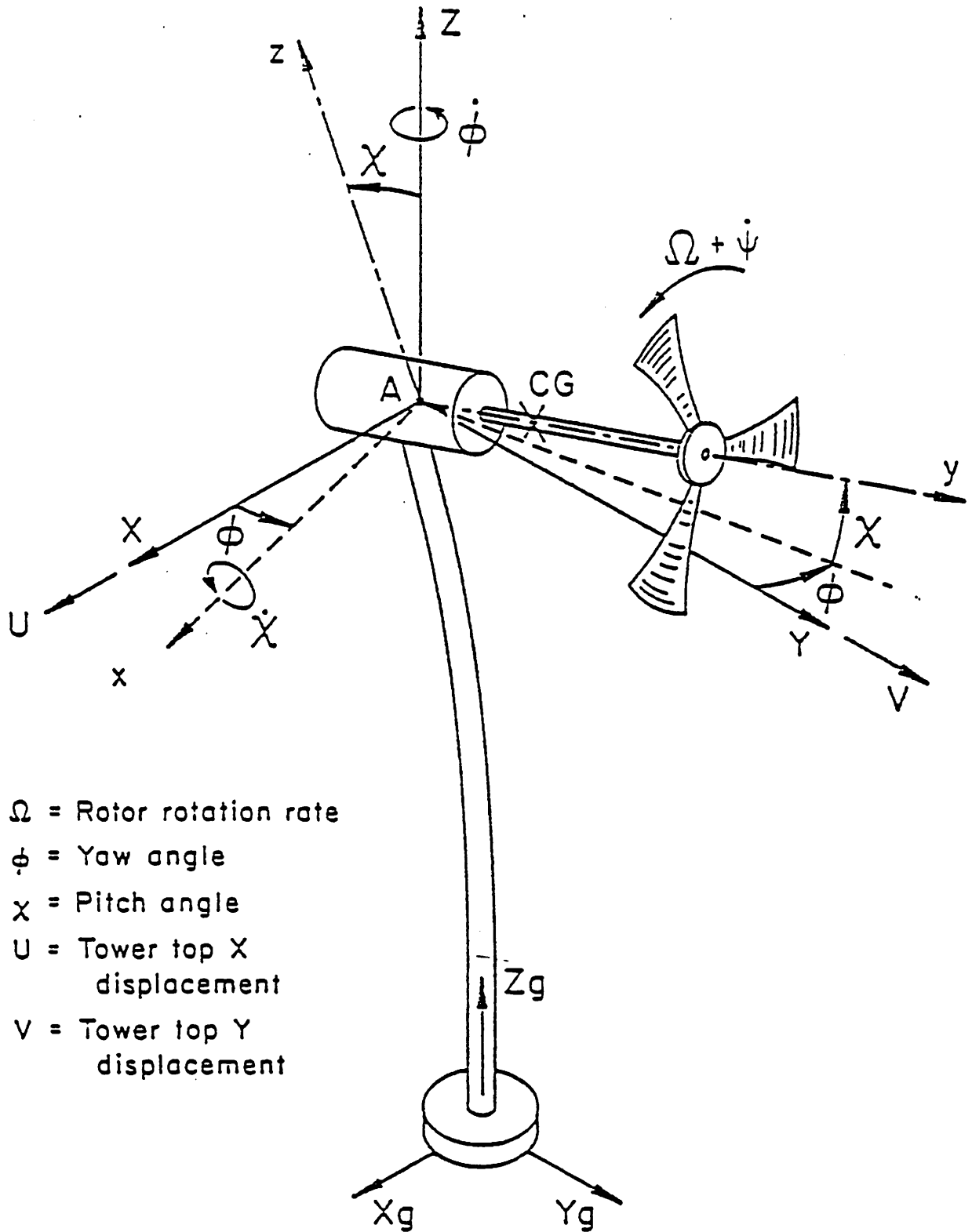

Figure 1. The Turbine Model

$$(5) \quad [M]\{\ddot{X}\} + [C]\{\dot{X}\} + [K]\{X\} = \{Q_1\} + [F]\{u\}$$

where  $[M]$ ,  $[C]$ ,  $[K]$ , and  $[F]$  are the inertia, damping, stiffness, input coefficient matrices,

$$\{X\}^T = (U, V, \phi, \chi, \psi) = \text{displacement coordinate}$$

$$\{Q_1\}^T = (0, T, 0, Q, 0) = \text{steady state}$$

$$\{u\}^T = (V_x, V_y, V_z, \bar{V}_{y,x}, \bar{V}_{y,z}, \gamma_{xz}, \epsilon_r, \bar{\gamma}_r, \bar{\epsilon}_{xz}) = \text{wind inputs}$$

$$\epsilon_r = \epsilon_{zx} \cos 3\Omega t + \bar{\gamma}_{zx} \sin 3\Omega t$$

$$\bar{\gamma}_r = -\epsilon_{zx} \sin 3\Omega t + \bar{\gamma}_{zx} \cos 3\Omega t$$

The terms  $\epsilon_r$  and  $\bar{\gamma}_r$  come from the three-bladed sums of the aerodynamic forces that involve  $\sin(2\Omega t)$  and  $\cos(2\Omega t)$ .

Discarding the steady terms, it is convenient to transform these turbine equations to the state space form, and to augment them with the nine wind input equations. This forms a single set of equations with white noise as the driving input. These may be written as

$$(6) \quad \{\dot{x}\} = [A]\{x\} + [B]\{w\}$$

$$\{y\} = [C]\{x\}$$

where

$$\{x\} = \begin{Bmatrix} \{X\} \\ \{\dot{X}\} \\ \{u\} \end{Bmatrix} \quad [A] = \begin{bmatrix} [0] & [I] & [0] \\ -[M]^{-1}[K] & -[M]^{-1}[C] & [M]^{-1}[F] \\ [0] & [0] & [\hat{a}] \end{bmatrix}$$

$$[B] = \begin{bmatrix} [0] \\ [\hat{b}] \end{bmatrix} \quad \{y\} = \left\{ \begin{array}{l} F_x \\ F_y \\ M_z \\ M_x \\ \text{Power} \\ \{x\} \end{array} \right\} = \text{outputs}$$

[C] = response matrix

The displacements represented by  $\{x\}$  and velocities given by  $\{\dot{x}\}$  are deviations from the steady values. The outputs  $\{y\}$  are selected by the user, and depend on the coefficients of the response matrix [C]. With this formulation it is a relatively straightforward numerical procedure, to determine the complex eigenvalues of the A matrix and then to compute the modal matrix, which is made up of the associated eigenvectors. The modal matrix can then be used to decouple the equations of motion so that transfer functions between any of the nine white noise inputs and any output,  $y_i$ , may be easily computed. These transfer functions account for differences in the energy level for the turbulence inputs,  $\{u\}$ , so that a comparison of the transfer function magnitudes provides a direct estimate of relative importance. The final result uses the central equation from random vibration theory Eq. (7), which states that the spectral density for any of the outputs  $\{y\}$  will be given by

$$(7) \quad \{S_y(\omega)\} = [ |H_{yw}(\omega)|^2 ] \{S_w\}$$

for uncorrelated inputs. In this equation,  $\{S_y(\omega)\}$  is the spectral density of the outputs  $\{y\}$ ,  $[ |H_{yw}(\omega)|^2 ]$  is the matrix consisting of elements which are the

Table 2. Mod-G Characteristics

Rotor Characteristics:

Rotor Radius	150	ft
Blade Chord (linear taper)	7.74	ft
	at hub to	
	3.15	ft
	at tip	
Coning Angle	4°	
Blade Twist (linear)	8°	

System Frequencies:

1st Bending (fore-aft)	(1.5 $\Omega$ )	2.7	rad/s
2nd Bending (fore-aft)	(7.5 $\Omega$ )	13.7	rad/s
1st Bending (side-to-side)	(1.6 $\Omega$ )	2.9	rad/s
1st Torsion	(4.9 $\Omega$ )	9.0	rad/s

Aerodynamic Properties:

Lift Curve Slope	5.73
Drag Coefficient, $C_{D0}$	.008
Stall not Modeled	

Operating Conditions:

Wind Velocity	(1.833	20	MPH
	rad/s)		
Rotor Speed		17.5	RPM
Pitch Setting at Tip		-6.2°	
Turbulence Length Scale		500	ft
Rms turbulent intensity		2.44	ft/s
Approximate Power Output		1.1	MW



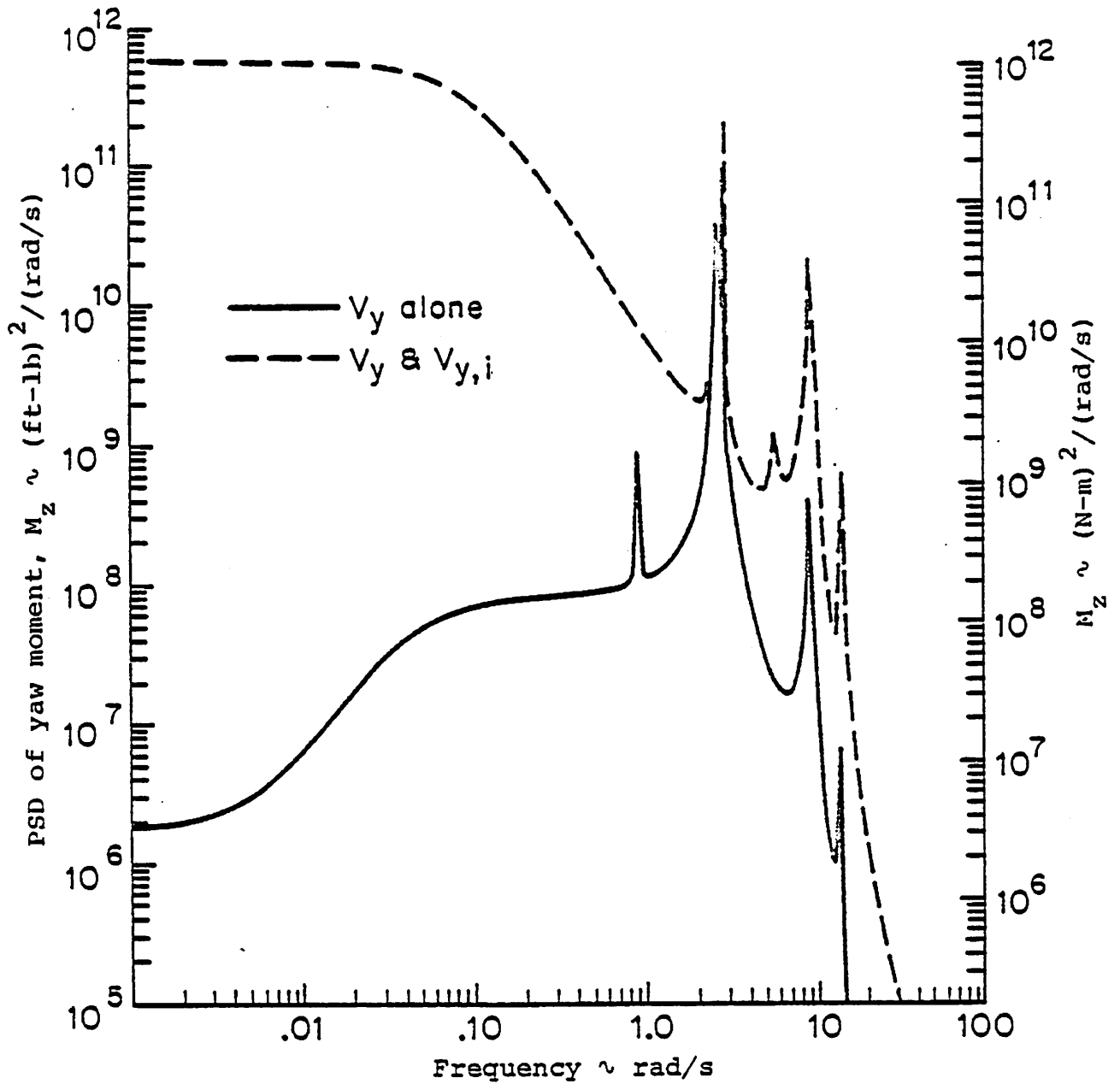

Figure 2. The effect of the gradients  $v_{y,x}$  and  $v_{y,z}$  on yaw moments for Mod-G using the equilibrium wake.

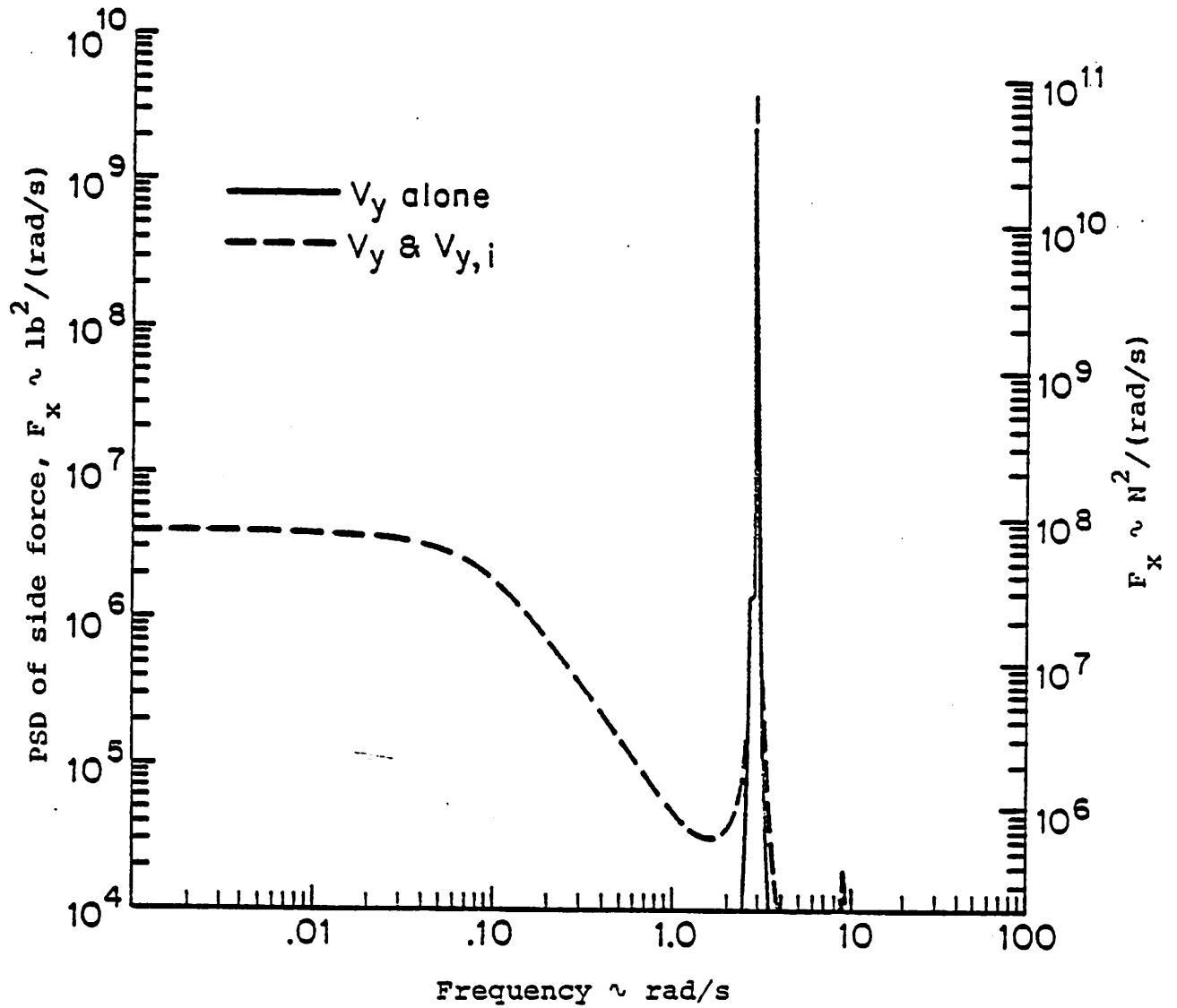

Figure 3. The effect of the gradients  $v_{y,x}$  and  $v_{y,z}$  on the side force for Mod-G using the equilibrium wake.

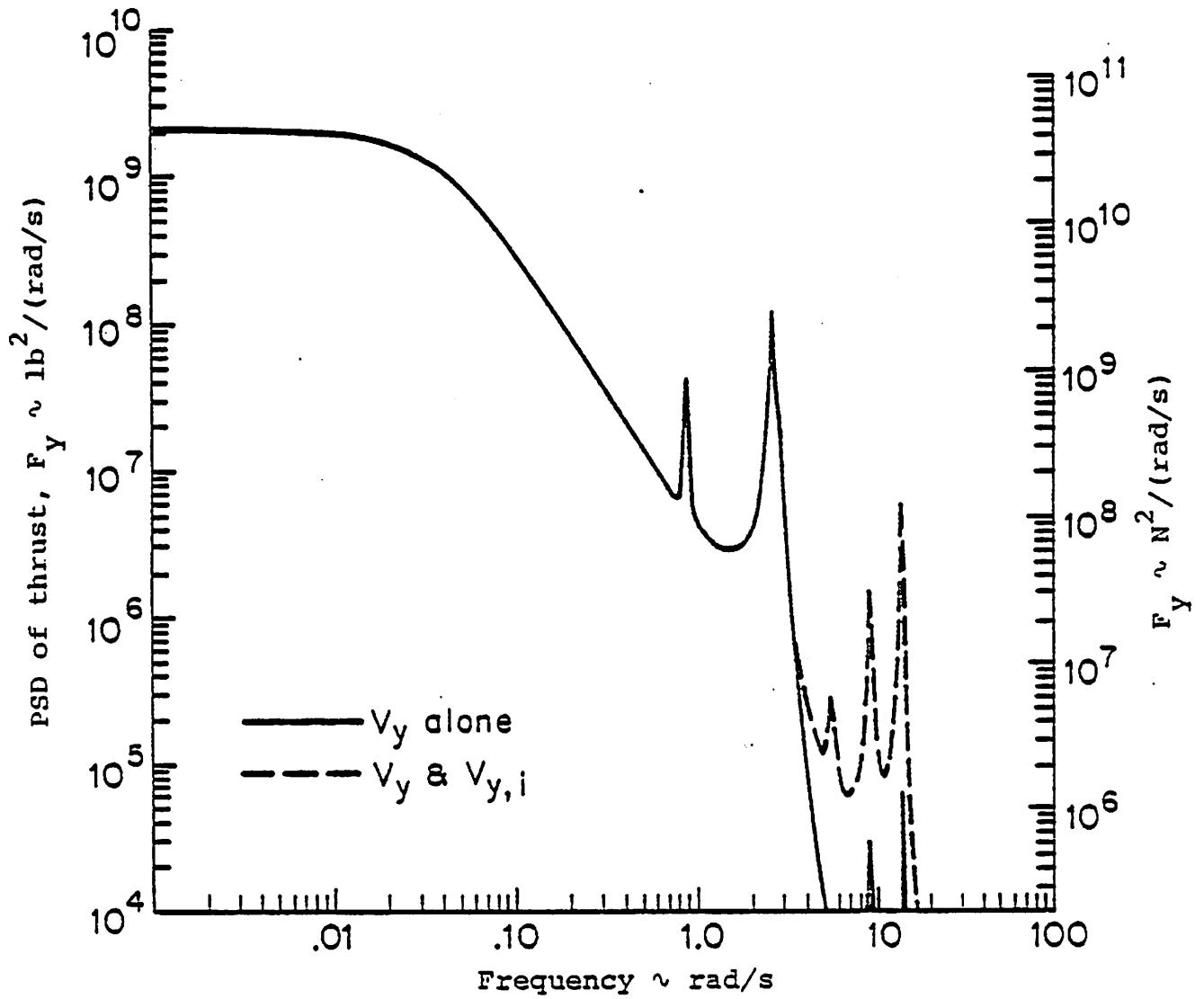

Figure 4. The effect of the gradients  $v_{y,x}$  and  $v_{y,z}$  on thrust for the Mod-G using the equilibrium wake.

square of the transfer function magnitude and  $\{S_w\}$  is the flat spectral density of the white noise driving inputs, which are all equal.

Using this procedure a large wind turbine called the Mod-G was analyzed. The Mod-G is a 2.5 MW turbine with a three-bladed rotor located upwind of the tower, and is designed for fixed-yaw operation. The specific characteristics of this system are shown in Table 2. Figures 2 through 4 present the computation results for the Mod-G turbine.

The primary objective of this work was to identify the features of turbulence which are most important in wind turbine design. In an effort to focus on these key features, the response at specific system frequencies was broken down into fractional contributions from each turbulence input. The most significant results of these calculations are tabulated in Table 3.

From these results it seems clear that the most important inputs are the longitudinal turbulence component,  $V_y$ , the two associated gradient terms  $V_{y,x}$  and  $V_{y,z}$ .

To examine this conclusion more closely, consider again Figures 2 through 4, which present plots of power spectral densities for the various response variables using, first, only the turbulence input  $V_y$ , and then comparing it with the results when the two gradients  $V_{y,x}$  and  $V_{y,z}$  are added to the input. The figures clearly show that the response is significantly underestimated unless the turbulence gradient terms  $V_{y,x}$  and  $V_{y,z}$  are included.

There are two simple conclusions which arise from the results presented here. First, the turbine response to atmospheric turbulence should be obtained using a coupled dynamic model which inputs the wind excitations over the appropriate frequency range. If this is not done, then all of the turbine natural frequencies will not be excited in a realistic manner. In addition, it is essential to model the spatial variations in wind velocity caused by turbulence.

Table 3. Fractional Response Contributions of the Turbulence Inputs for the Mod-G Using the Equilibrium Wake

Response/Input	$V_y$	$V_{y,x}$	$V_{y,z}$	$\epsilon_r$	$\bar{Y}_r$	Other
<u>Frequency = 0</u>						
Side Force, $F_x$	.0	.06	.92	.0	.0	.02
Thrust, $F_y$	1.0	.0	.0	.0	.0	.0
Yaw Moment, $M_z$	.0	.97	.0	.0	.0	.03
Pitch Moment, $M_x$	.0	.0	.97	.0	.0	.03
<u>Frequency = 2.69 (Fore-Aft Bending)</u>						
Side Force, $F_x$	.93	.04	.02	.0	.0	.01
Thrust, $F_y$	.78	.0	.21	.0	.0	.01
Yaw Moment, $M_z$	.77	.02	.20	.0	.0	.01
Pitch Moment, $M_x$	.78	.0	.21	.0	.0	.01
<u>Frequency = <math>3\Omega = 5.5</math></u>						
Side Force, $F_x$	.02	.39	.09	.25	.24	.01
Thrust, $F_y$	.01	.02	.19	.38	.39	.01
Yaw Moment, $M_z$	.02	.31	.0	.34	.32	.01
Pitch Moment, $M_x$	.01	.02	.20	.38	.39	.0
<u>Frequency = .89 (Drive Train)</u>						
Side Force, $F_x$	.0	.08	.90	.0	.0	.02
Thrust, $F_y$	1.0	.0	.0	.0	.0	.0
Yaw Moment, $M_z$	.11	.87	.01	.0	.0	.01
Pitch Moment, $M_x$	.01	.0	.97	.0	.0	.02

## FATIGUE DAMAGE

For a structure exposed to a Gaussian narrow band loading, there are several approaches to computing the expected life. The most straightforward is the Palmgren-Miner rule. This rule states that, if  $n_i$  cycles occur at stress level  $s_i$ , and at constant amplitude, it would take  $N_i$  cycles at this level for failure, then the fractional damage at  $s_i$  is  $(n_i/N_i)$ . Failure is expected when the sum of all the fractional damages equals unity. That is when

$$\sum_i (n_i/N_i) = 1$$

From this it is possible to determine the time to failure as

$$T = \frac{1}{v_0^+ \int_0^\infty \frac{P_p(s) ds}{N(s)}}$$

where  $N(s)$  = the number of cycles to failure at  $s$ .

$$v_0^+ = \frac{1}{2\pi} \frac{\sigma_{\dot{s}}}{\sigma_s} = \text{zero crossing frequency.}$$

$$P_p(s) = \frac{s}{\sigma_s} e^{-s^2/2\sigma_s^2} = \text{probability density function of stress peaks.}$$

$$\sigma_s^2 = \text{the variance of the stress, } s.$$

$$\sigma_{\dot{s}}^2 = \text{the variance of } \dot{s}.$$

The variance can be computed from the power-spectral-density by direct integration or directly from the system governing equations. For a single response variable, this would be

$$\sigma_s^2 = \int_{-\infty}^{\infty} S_s(\omega) d\omega$$

and

$$\sigma_s^2 = \int_{-\infty}^{\infty} \omega^2 S_s(\omega) d\omega$$

where  $S_s(\omega)$  is the power-spectral-density for the stress  $s$ . Note that these two integrals represent areas under spectral density curves.

Alternately, fracture mechanics techniques can be used. Fatigue-crack-growth data can be conveniently represented by the equation

$$\frac{da}{dN} = C(\Delta K_I)^m$$

where  $a$  is crack length;  $N$  is the number of cycles;  $C$  is a material constant;  $\Delta K_I$  is the range of the stress intensity factor; and  $m$  is an exponent in the range 2-4.

Using this approach Pook and Greenan (3) have performed statistical computations similar to those presented above for Miner's rule, and compared the results with a limited amount of experimental data for mild steel under narrow-band random loading. Results for this work are reproduced in Figure 7. The spread in the predictive results would seem to indicate that there is still some research work that needs to be done.

These results apply only for narrow-band random loading. For wind systems the response is generally wide-band with major contributions at the natural frequencies of the system. While the above methods can be modified to the more complex situation of wide-band loading as Holley (4) has demonstrated, the linear damage rules do not predict damage nearly so well as for narrow-band loading. In general, prediction of fatigue life under wide-band random loads is considered to be a research topic of significant difficulty.

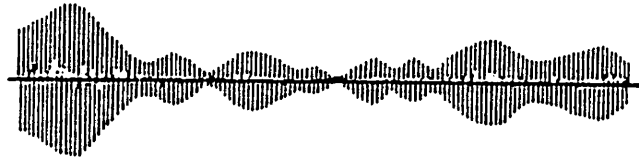

Narrow-band random loading.

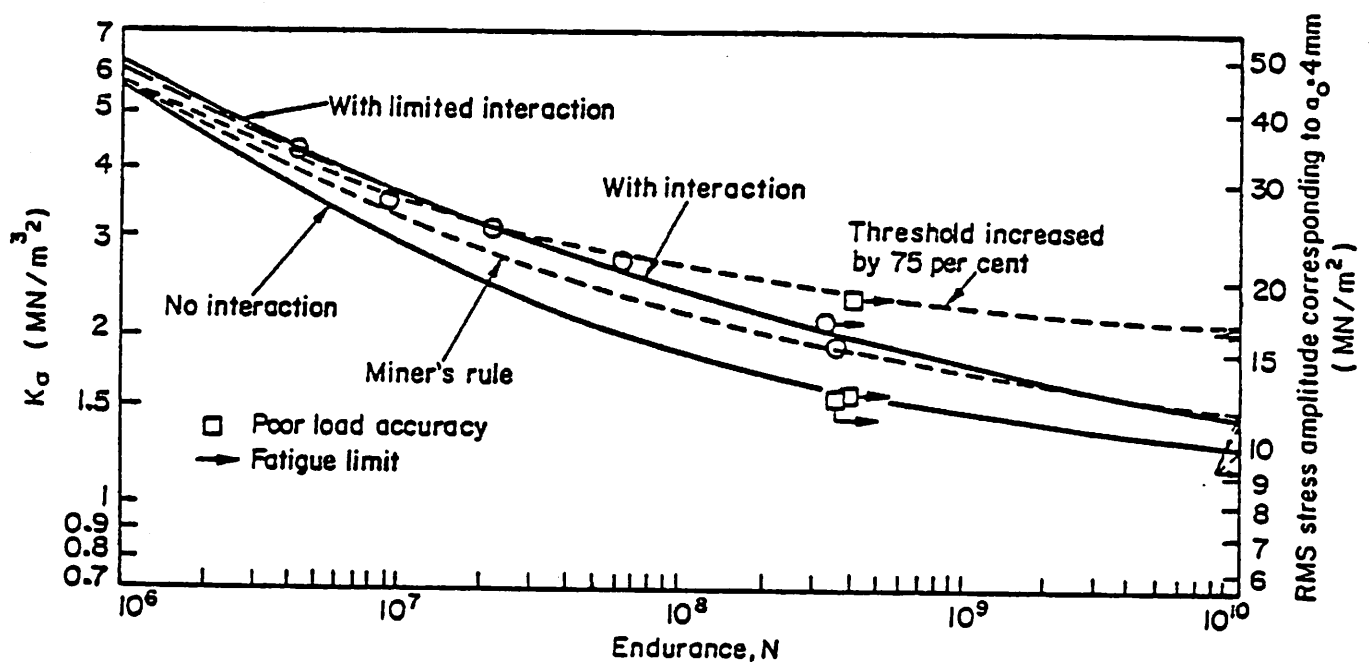

Figure 5. Results of comparison and loading from reference (3).



## CONCLUSIONS AND RECOMMENDATIONS

This paper has put forth the following major points:

1. For computation of wind turbine loads, the turbulence inputs must include terms which generate a nonuniform spatial distribution of velocity over the rotor disk, otherwise important excitations will be lost.
2. The procedures used to compute the dynamic loads caused by turbulence must allow a full dynamic response to these inputs. Quasi-steady computation and the use of discrete deterministic gusts will probably give misleading results.
3. The response of wind turbines to turbulence inputs tends to be wide-band, and the usual fatigue damage rules may not provide accurate estimates of structural life for wide-band loading. This problem is not, however, unique to wind systems. It is a generic problem common to many mechanical systems, and should be classified as a "basic research issue" of significant importance to the success of wind energy systems.

In addition to these major points, the authors would like to make the following recommendations:

1. At this point in time, there is little experimental data, in the form of spectral-density plots of machine loads, to use as a guide for model development and setting design criteria. This type of data would be very helpful, and should be developed and published. For a complete picture, the associated wind data is also necessary.
2. Because the governing equation for two-bladed wind turbines contains periodic coefficients, it would appear at first that frequency domain techniques are not practical. However, Holley and Bahrami (5) have extended the analysis

presented here using Floquet theory to periodic linear systems. In addition, under some simplifying assumptions, it may be possible to use the nonlinear time domain computer codes already developed for dynamic analysis of turbines to compute a set of transfer functions relating a specific wind turbulence input and any desired responses. For example, a nonlinear code could be used to compute the response to a mean wind and a suddenly applied linear gradient across the disk,  $V_{y,x}$ , where the gradient time history is a square wave of several cycles with each cycle of shorter duration to fully excite higher turbine natural frequencies. From the time history of the input and any particular output, a transfer function could then be computed numerically. This would provide a set of linearized transfer functions which would contain the proper frequencies, but would in some sense average-out the effect of the periodic coefficients. This approach has the advantage of using the existing codes and allowing the turbulence calculations to be done separately, but would need to be fully validated for design use.

3. Some form of time domain analysis should also be developed. However, it seems likely that the computation time for a full system simulation will be long. For this reason, it may be best to model only the power train and rotor system to validate the turbulence input modeling with field test data. After validation of the technique, a more comprehensive turbine system model could be developed.

## ACKNOWLEDGEMENTS

This research was supported by the U.S. Department of Energy through Battelle, Pacific Northwest Laboratory. The authors would like to thank Dr. J. R. Connell for his helpful and enthusiastic support, and the many valuable suggestions made by the PNL staff.

## REFERENCES

1. Thresher, R. W., et al., Modeling the Response of Wind Turbines to Atmospheric Turbulence, Oregon State University Report RLO/2227-80/2, 1981.
2. Thresher, R. W. and Holley, W. E., The Response Sensitivity of Wind Turbines to Atmospheric Turbulence, Oregon State University Report RLO/2227-81/2, UC-60, August 1981.
3. L. P. Pook and A. F. Greenan, "The Effect of Narrow-band Random Loading on the High Cycle Fatigue Strength of Edge-Cracked Mild Steel Plates," Int. J. Fatigue, January 1979, pp. 17-22.
4. Holley, R. E. and Thresher, R. W., "Response of Wind Turbines to Atmospheric Turbulence," presented at Wind Workshop V, Washington, D.C., October 1981.
5. Holley, W. E. and Bahrami, M., "Periodic Linear Systems Forced by White Noise with Wind Turbine Applications," Proceedings of the 15th Asilomar Conference on Circuit Systems and Computers, Pacific Grove, CA, November 9-11, 1981.

## DYNAMIC ANALYSIS OF WINDTURBINE ROTORS FOR LIFETIME PREDICTION

by

P. Hauge Madsen\* )

Abstract. An overview of an ongoing project on prediction of lifetime of rotors of propellertype windturbines is given, and the models necessary for the analysis, loadmodels, aerodynamic and structural models, are shortly discussed. The effect of wind turbulence is introduced using the concepts of stationary random vibration and the covariance structure of the stochastic turbulence model is presented.

A new fatigue model and an approach to extreme response calculations have been derived, which take into account both the periodic and the stochastic part of the stress responses. Finally, some results of test calculations are shown, and a few conclusions are made.

\* ) Meteorology Section, Physics Department  
Risø National Laboratory  
DK-4000 Roskilde  
Denmark

## 1. INTRODUCTION

During the last few years with the rapid technical development of small-scale windturbines the cause of structural failure of such has changed from arising from missing understanding of extreme short term loading to being one of accumulative damage or material fatigue. Thus, several failures due to fatigue cracks in the load-carrying structure have occurred both on small and large windturbines, the sensitive point being the rotor system. The economic viability of wind energy being strongly dependent of the lifetime of the turbines has made fatigue analysis increasingly important, and a need of thorough understanding of the dynamic loading and efficient tools for lifetime evaluation has arisen.

For this reason a project was started at Risø National Laboratory in 1981 under contract with the Research Association of the Danish Electricity Supply Undertakings (DEFU) with the purpose of developing a computer code, specifically directed against the prediction of windturbine lifetime. In that respect the program differs from other computer codes for windturbine calculations such as MOSTAS [1] and DYNAWECS [2], which for a given load time-history very accurately can predict the structural response of the turbine. In contrast the emphasis in the present project has been on the load representation and on the final evaluation of the calculated stress-responses with respect to fatigue and extreme stresses.

In short the objectives of the work have been to

- analyse and predict the lifetime of the rotor system of a horizontal axis windturbine design
- identify the important sources of loading; e.g. gravity, wind shear, wind turbulence

- identify load cases, characterized by windspeed and operational mode, at which the extreme loading of the turbine occurs.

Since lifetime prediction requires a large number of load cases to be analyzed, some effort has been made to make the program computationally efficient, thus the frequency domain technique has been adopted for the response analysis of normal operation conditions at the cost of a basic assumption of system linearity, constant rotation speed and only partially including the tower flexibility.

Prior to the analysis the spectrum of load conditions that a windturbine experiences during its lifetime must be made discrete into a finite number of loadcases. Three major operational modes are considered, the stand-still position, which for fatigue and extreme responses only is of interest for very high windspeeds, normal operation and the nonstationary start and stop procedures. The basic philosophy for the first two modes is that the lifetime is divided into segments of 10 minutes duration in which the windspeed is modelled as a stationary ergodic Gaussian stochastic process, characterized by a constant mean windspeed and a power spectrum of the fluctuations. It is implied in the model that the fatigue damage and extreme stresses obtained from  $N$  segments with equal mean windspeed correspond to their equivalent from one segment of length  $N \times 10$  minutes. Hence the lifetime is divided into loadcases characterized by mean windspeed and operation conditions with the time duration being the fraction of time spent in that particular case, e.g.  $v = 8-10$  m/s, no yawing, wind direction perpendicular to the rotor plane.

The response analysis delivers for a given load case the stresses in terms of a periodic part and a stationary stochastic part. Two failure modes are considered, either the wind turbine structure fails from accumulated damage, or it fails due to the stress suddenly exceeding the short term strength. Essentially the fail-

ure modes are identical, however, since fatigue analysis using the Palmgren-Miner model and S-N curves is basically an average consideration, the separation was found necessary. In order to take into account the special structure of the stress response signals both a new fatigue model and an extension of the usual approach to calculate the extreme of a stochastic process have been derived. The models are analytical and a simulation of the wind response is thus avoided.

The synthesis of various models of loads, aerodynamics, structures, material fatigue, etc. into an efficient tool for lifetime prediction is considered to be the main achievement of the project. However, a number of models have been derived among which the most interesting are presented in the following. Presently, for the category of wind turbines mentioned in the objectives, the developed computer program is felt to be an efficient tool for lifetime calculations, and a significant number of load cases can be analysed at a moderate computational cost. In the end of the paper some preliminary results of a test analysis of a Nibe-B type turbine are presented, which illustrate the capabilities of the program.

## 2. ELEMENTS IN THE ANALYSIS

An essential point in a lifetime analysis is the assessment of the external loadings and the operational condition which a given wind turbine will experience. A simple approach, which probably accounts for most of the lifetime, consists of dividing the wind speed distribution for various terrain classes, Petersen et al. [3], into a finite number of wind speed intervals, each with a characteristic mean wind speed and a relative duration. As operation modes normal production operation at intermediate wind speeds and standstill position at very low and high wind speeds could be considered. However, in general many more operation modes should be included such as start and stop procedures, emer-



gency shut-down, production operation while yawing and various degrees of rotor misalignment. Combined with the possible wind speeds the operation modes constitutes the load cases to be considered.

Once a load case has been specified, the analysis of the wind turbine design with respect to damage rate and response extremes can be performed. The analysis model is a synthesis of various models as it is illustrated in Fig. 1. The component models are thoroughly described in Madsen et al. [4] and will only briefly be commented on here.

The loadgenerating phenomena consist of a nonuniform windfield, forces due to rotation such as centrifugal forces and gyroforces from yawing and gravity, which combined with tolerance effects e.g. differences in blade masses and setting of profile angles give rise to dynamic loading. The variation in wind speed across the rotor disc is due to wind shear, interferences with the tower, misalignment of the rotor and wind turbulence. In order to evaluate the corresponding wind load on the rotor, an aerodynamic model is necessary. In the present context the blade element theory of Glauert [5], which includes both induced axial flow as well as induced rotational flow, is used. The load derivatives with respect to perturbations in wind speed are derived from this theory, assuming that the induced velocities obtain their steady-state values for the instantaneous wind speed, the so-called "Equilibrium wake" approach, Thresher et al. [6]. The derivatives are then used as proportionality coefficients between fluctuations in wind speed and pressure. Apart from the turbulence all loads are periodic during normal operation and are represented in terms of their Fourier coefficients.

The wind turbine is described in rotating coordinates by a linear structural model. The structural model is formulated by means of a general purpose finite-element program and the number of degrees of freedom is reduced by representing the dynamic displacements in terms of a limited number of natural mode shapes.

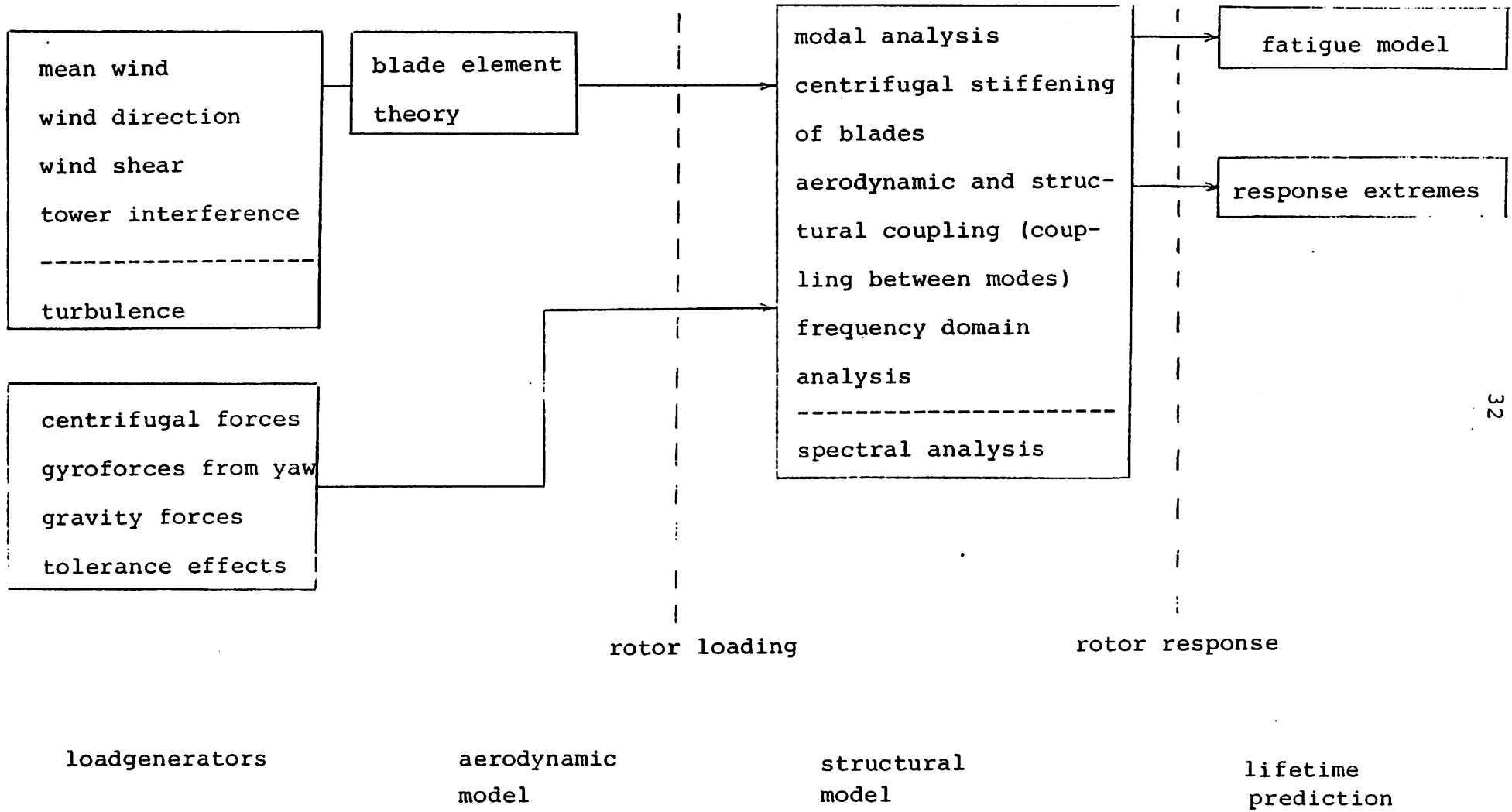

Fig. 1. Elements in the analysis

At normal operation conditions the response problem is solved in the frequency domain, which requires system linearity. Hence, the aeroelastic coupling between blade velocity and aerodynamic force is linearized, and the term included as an aerodynamic damping. A linearization of the nonlinear coupling blade displacement / centrifugal forces result in an artificial additional stiffness, Putter and Manor [7], and the corresponding change in mode frequencies is found by a perturbation technique, Collins and Thompson [8].

Finally the stress response of the rotor components are evaluated by means of a fatigue model and a model for extreme responses in order to obtain damage and extreme stresses for that particular load case. The models are further discussed in section 4.

### 3. STOCHASTIC MODEL OF WIND TURBULENCE

Undoubtedly the action of wind turbulence on wind turbines is important when extreme stresses and fatigue lifetime are considered. However, there exists discussion on which way to represent the wind fluctuations for calculations, namely either by a discreet gust model having a gust shape, duration and amplitude or by a stochastic process model. The latter is adopted here, thus representing the wind fluctuations as a zero-mean Gaussian stationary process with a frequency content characterized by a power spectra.

Basically the model is rather simple, the turbulence is assumed to be both isotropic and homogeneous, and only the alongwind component is considered due to this component being dominant in the turbulence loading, Jensen and Frandsen [9].

The turbulence model is thoroughly described in Kristensen and Frandsen [10], who have based their model on the earlier work by Rosenbrock [11]. Using the von Karman energy spectrum to describe

the turbulence, the longitudinal correlation function and the associated power spectrum becomes

$$R_2(v) = \frac{2\sigma_0^2}{\Gamma(1/3)} \left(\frac{r}{2L}\right)^{1/3} K_{1/3}(r/L) \quad (1)$$

and

$$S_L(\omega) = \frac{\Gamma(5/6)}{\Gamma(1/3)} 2\sqrt{\pi}\sigma_0^2 \frac{L/U}{\left(1 + \left(\frac{\omega L}{U}\right)^2\right)^{5/6}} \quad (2)$$

in which  $K_{1/3}$  is a modified Bessel function of the second kind of order  $1/3$ .  $U$  is the mean wind speed at the observer's height, and the variance  $\sigma_0^2$  and the length scale  $L$  are determined from

$$\sigma_0^2 = \frac{U}{\ln(z/z_0)} \quad (3)$$

Lumley and Panofsky [12], in which  $z$  is the height above the ground, and  $z_0$  is the roughness length, and

$$L = 6.5 z \quad (4)$$

(4) ensures that the maximum of  $\omega S_L(\omega)$  occurs at the frequency  $f_m = \omega z / (2\pi U) = 0.03$ , Simiu and Scanlan [13]. Assuming incompressibility the covariance tensor of the along wind fluctuation at two points separated the distance  $r$  and the distance

$$r_1 = Ut \quad (5)$$

in the wind direction can be expressed as, Engelund [14],

$$R_{11}) = R_L(r) - \frac{r}{2} \frac{dR_L(r)}{dr} \left(1 - \frac{r_1^2}{r^2}\right) \quad (6)$$

For two points rotating with the angular velocity  $\omega_R$  and mutual location given by the radii  $a$ ,  $b$  and the angle  $\phi$ , the distance  $r$  as a function of time can be written

$$r = \sqrt{r_1^2 + r_p^2} \quad (7)$$

in which  $r_p^2$  is given by

$$r_p^2 = a^2 + b^2 - 2ab \cos(\omega_R \tau + \phi) \quad (8)$$

as is illustrated on Fig. 2.

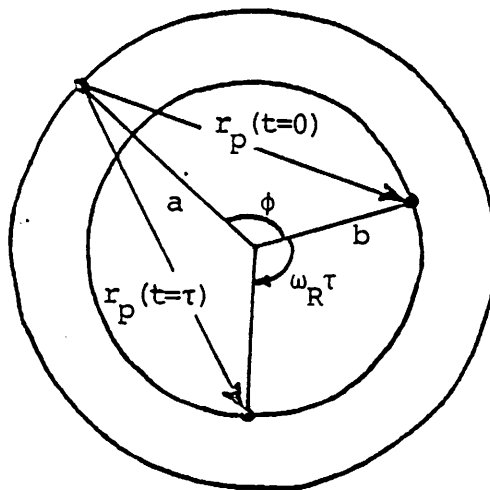

Fig. 2. Distance between points in the rotorplane as function of time.

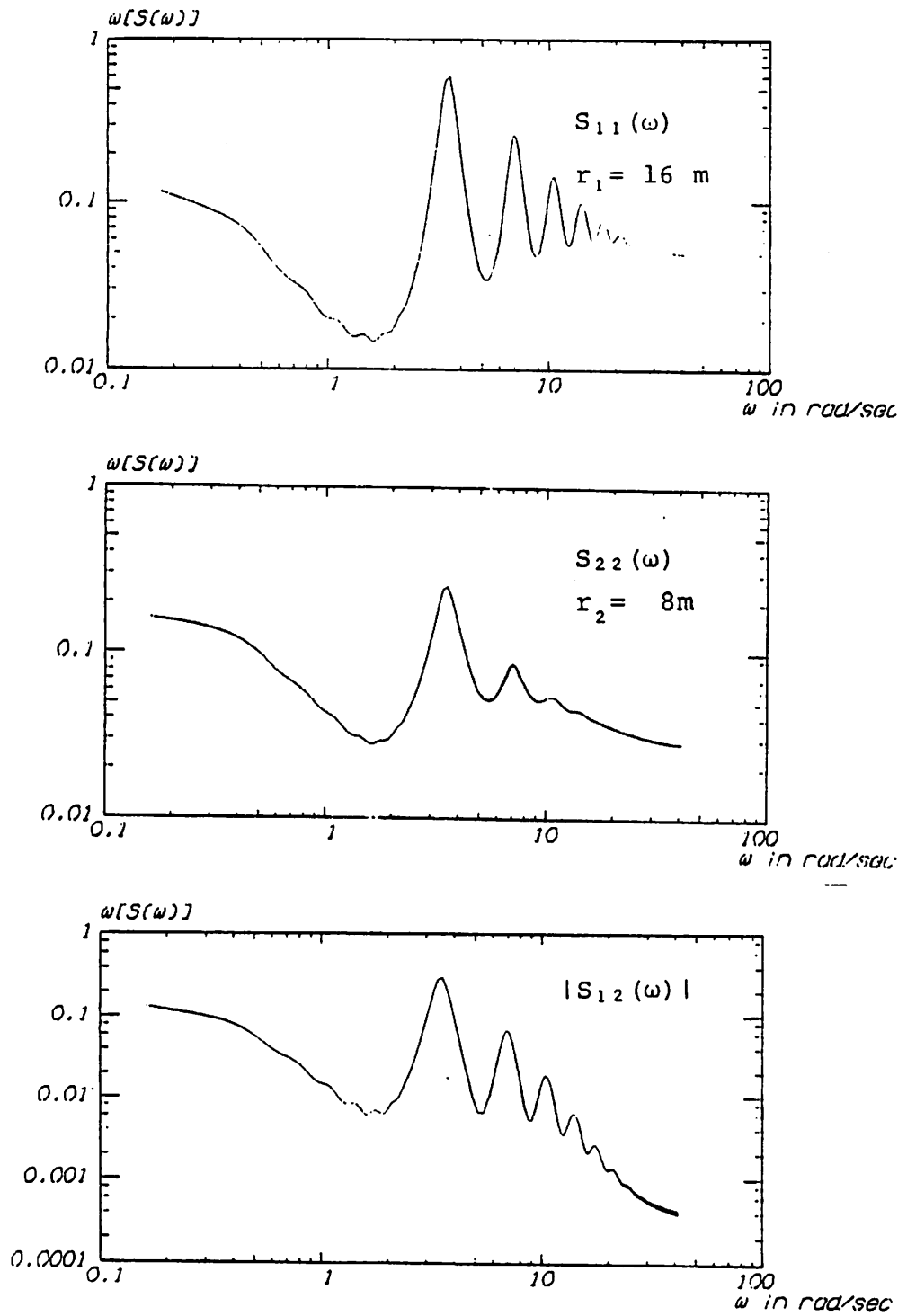

Fig. 3. Auto- and cross-spectra at two points on a rotating wind turbine blade.

Inserting (7) into (6) the covariance can be written as functions of time. The corresponding auto- and cross-spectra are found by

$$S_{11}(\omega) = \int_{-\infty}^{\infty} R_{11}(\tau) e^{-i\omega\tau} d\tau \quad (9)$$

The Fourier integral in (9) must be calculated using a numerical digital Fourier transform. In Fig. 3 the auto- and cross-spectra for two points on a rotating blade are shown.

To obtain the spectra of the modal turbulence load, the spectra times the mode shape vectors must be integrated over the rotor. In the program a gauss-integration procedure is used and 3-5 gauss-points per blade must be used to obtain a reasonable accuracy, when the first two flapwise and chordwise bending modes of the blades are included in the analysis.

#### 4. FATIGUE MODEL AND EXTREME RESPONSE

From the response analysis the various stress responses at the selected points appear in the form

$$Y(t) = Z(t) + X(t) \quad (10)$$

in which  $Z(t)$  is a periodic function expressed as a truncated Fourier series

$$Z(t) = \text{Re} \left[ \sum_{n=0}^N \alpha_n e^{in\omega_R t} \right] \quad (11)$$

and  $X(t)$  is a stationary Gaussian process with zero mean. The process  $X(t)$  is described by the spectral moments

$$\lambda_k = 2 \int_0^{\infty} \omega^k S(\omega) d\omega \quad (12)$$

where  $S(\omega)$  is the power spectrum of  $X(t)$ .

The fatigue model is based on material properties in terms of an S-N curve and the Palmgren-Miner linear damage model [15]. The model implies that the damage due to  $N$  time segments each with  $n_i$  sinusoidal cycles having the stress range  $\Delta S_i$  becomes

$$D = \sum_{i=1}^N n_i \left( \frac{\Delta S_i}{S_1} \right)^m \quad (13)$$

in which  $S_1$  and  $m$  are the S-N curve material constants. For the complex signal  $Y(t)$  the first question is how to define a cycle. For a complex signal with known time history the rainflow counting procedure by Matsuishi and Endo [16], which counts cycles and ranges, gives good results. It is therefore a goal for an analytical approach to yield similar results.

As  $Y(t)$  is a stochastic signal, it follows that statistics of a number of cycles and stress ranges must be determined in order to calculate the expected damage rate, i.e. the damage per unit time. For a narrowband Gaussian process with zero mean  $X(t)$ , the realizations resemble sinusoids with slowly varying amplitudes. In this case the rises and falls are Rayleigh distributed, Crandall and Mark [17] and the expected damage rate can be written

$$E\{D\} = v_0 \left( \frac{\Delta S}{S_1} \right)^m \quad (14)$$

where the number of cycles are represented by  $v_0$ , the upcrossing rate.  $v_0$  is obtained from Rice's formula, [18]



$$v_0 = \int_0^{\infty} \dot{x} f_{X\dot{X}}(0, \dot{x}) d\dot{x} = \frac{1}{2\pi} \sqrt{\lambda_2/\lambda_0} \quad (15)$$

where  $f_{X\dot{X}}$  is the joint probability function of  $X(t)$  and its time derivative. The associated stress range  $\Delta s$  is

$$\Delta S = \sqrt{8\lambda_0} \Gamma(1+m/2)^{1/m} \quad (16)$$

where  $\Gamma(\ ) =$  gamma function.

For a Gaussian stress signal, which is not narrowbanded, Wirsching and Light [19] have proposed an equivalent stress range of the form

$$\Delta S = g(\alpha, m) \sqrt{8\lambda_0} \Gamma(1+m/2)^{1/m} \quad (17)$$

$g(\alpha, m)$  is an empirical determined correction function, which depends on the material parameter  $m$  and

$$\alpha = v_0/v_m \quad (18)$$

$v_m$  being the expected number of maximas given by, Rice [20]

$$v_m = \int_{-\infty}^{\infty} \dot{x} f_{X\ddot{X}}(0, \ddot{x}) d\ddot{x} = \frac{1}{2\pi} \sqrt{\lambda_4/\lambda_2} \quad (19)$$

In the present model, Madsen et al. [21], a similar approach has been taken. Thus the number of cycles is still given by the up-crossing frequency  $v_0$ , whereas the stress range becomes

$$\Delta S = \sqrt{8\lambda_0 g_x} [\Gamma(1+m/2)M(-m/2, 1, -\beta^2)]^{1/m} \quad (20)$$

$M( , , )$  is a confluent hypergeometric function and

$$\beta = \frac{g_z \sigma_z}{g_x \sqrt{\lambda_0}} \quad (21)$$

$$g_z = 1.24 - (0.325 - 0.025 m)(2.2\alpha - \alpha^2) \quad (22)$$

$$g_x = 0.93 - 0.07 \alpha^5 \quad (23)$$

$\sigma_z$  is the standard deviation of the periodic signal  $Z(t)$  and  $\alpha$  is still defined by (18). For the combined signal  $Y(t)$ ,  $\nu_0$  and  $\nu_m$  are still given by the integrals (15,19), however, the joint density functions get rather complicated and the integration must be performed numerically.

For a narrowband combined signal,  $\alpha = 1$ ,  $g_x = 1$ ,  $\beta = \sigma_z/\sqrt{\lambda_0}$ , the model yields the exact result, Rice [22], and the correction functions are based on rainflow counting on simulated processes and experimental results where possible.

An estimate of the lifetime  $T$  is then obtained as

$$T = D_{\text{failure}} \left[ \sum_i p_i E\{D_i\} \right]^{-1} \quad (24)$$

where  $D_{\text{failure}}$  is the damage at failure and  $p_i$  is the fraction of time spent in loadcase No.  $i$ .

Due to the stochastic part of the response process  $Y(t)$ , the maximum of  $Y(t)$  during the time  $p_i T$  spent in loadcase No.  $i$  is also a random quantity. In order to avoid failure, the maximum stresses

from all loadcases must be below the material short term strength. The criteria for adequate strength in this context can be formulated in two ways, either the probability of  $Y(t)$  exceeding the strength during the wind turbine lifetime should be acceptably small, or a characteristic value of the extreme of  $Y(t)$  must be shown to be less than a characteristic strength. The first criteria makes the best use of the information in the model, whereas the latter probably is the most familiar to the engineer.

Along the lines of gust loading factors for building structures, Davenport [23], a characteristic extreme will be defined as the mean value in the asymptotic Extreme-1 distribution of the largest extreme. As in Davenport [23] the derivation of the parameters in this distribution is based on the asymptotic distribution for large values of the local maximas, which can be expressed in terms of the threshold upcrossing frequency, Krenk [24]. For the combined signal  $Y(t)$ , the expected value of the largest extreme cannot be given in closed form. However, in Madsen et al. [25] it is demonstrated that the characteristic extremes during a time interval  $T$  with good accuracy can be approximated by

$$\frac{\mu_{\max}^* - Z_{\max}}{\sqrt{\lambda_0}} = \sqrt{2 \log(\zeta v_0 T)} + \frac{\gamma}{\sqrt{2 \log(\zeta v_0 T)}} \quad (25)$$

$$\frac{Z_{\min} - \mu_{\min}^*}{\sqrt{\lambda_0}} = \sqrt{2 \log(\xi v_0 T)} + \frac{\gamma}{\sqrt{2 \log(\xi v_0 T)}} \quad (26)$$

in which  $\gamma = 0.5772$  (Eulers constant) and  $v_0$  are given by the spectral moments by (14).  $Z_{\min}$ ,  $Z_{\max}$  are the maximum and the minimum values of the periodic signal and  $\mu_{\max}^*$ ,  $\mu_{\min}^*$  are the expected values of the largest and smallest extreme during  $T$ . The time scaling coefficient  $\zeta$ ,  $\xi$  are given by

$$\zeta = \sigma_z^2 / [(Z_{\max} - \mu_z)(Z_{\max} - Z_{\min})] \quad (27)$$

$$\xi = \sigma_z^2 / [\mu_z - Z_{\min})(Z_{\max} - Z_{\min})] \quad (28)$$

$\mu_z$  is the average value of the periodic signal  $Z(t)$ , and it is seen that for  $Z(t) = 0$  the results of Davenport [26] are obtained.

## 5. SOME RESULTS

Some preliminary calculations on the 630 kW Nibe-B turbine has been made. This turbine is three-bladed and pitch regulated, however, the regulation is active for windspeeds larger than 12 m/s only.

A finite-element model with 11 beam elements per blade has been formulated by means of the linear FE-program SAP IV [27]. To capture the dynamics the two first bending modes in both the flap and the chord direction as well as the first torsional drive train mode and a translational tower mode have been included.

The model environment in terms of terrain and windspeed distribution corresponds to the actual site, and seven loadcases each with a certain mean windspeed are included.

The parameters  $m = 5.5$  and  $S_1 = 1460$  MPa were used for the steel material, and results from the fatigue analysis are shown in table 1. It is seen that the sensitive point lies in the rotorplane due to gravity being a major source to the stresses in blades for this size of wind turbines.

The model predictions of mean  $\mu$ , rms values of the periodic  $\sigma_z$  and stochastic part  $\sigma_x$  of three responses are given in table 2. It is seen that turbulence is responsible for 50% of the vibrations in the flap direction in terms of base bending moment. In the chord-wise bending moments the gravity dominates, however, for large windspeeds the turbulence becomes significant and must be included both for fatigue and extreme value analysis. It is further seen



Mean wind speed m/s	Blade bending moments at base						Rotor thrust (kN)		
	Flapwise (kNm)			Chordwise (kNm)			$\mu$	$\sigma_z$	$\sigma_x$
	$\mu$	$\sigma_z$	$\sigma_x$	$\mu$	$\sigma_z$	$\sigma_x$	$\mu$	$\sigma_z$	$\sigma_x$
6	-91.7	22.2	21.4	9.2	116.	7.4	-95.2	0.6	5.1
8	-61.2	22.2	24.6	14.9	117.	7.7	-104.	0.6	6.1
10	- 8.6	23.2	28.2	29.1	117.	11.0	-117.	0.6	7.3
12	37.8	23.6	31.0	45.1	117.	14.9	-128.	0.6	8.4
14	3.6	26.4	34.5	55.1	117.	21.1	-123.	0.7	9.9
17	-64.6	35.7	38.9	43.1	117.	32.7	-111	1.0	12.2
21	-107.	45.7	43.7	25.3	117.	50.5	-105	1.2	15.6

Table 2. Calculated response statistics for various wind speeds.

- 1/1/00

	Flapwise base bending moment		Chordwise base bending moment		Drive moment on axle	
	Model	Measured	Model	Measured	Model	Measured
mean (kNm)	8	15	35	37	111	108
st.dev. (kNm)	37	35	118	129	28	23
min. (kNm)	-136	-135	-184	-194	28	24
max. (kNm)	132	122	251	261	160	151

Table 3. Comparison of statistics of response from measurements and calculations.

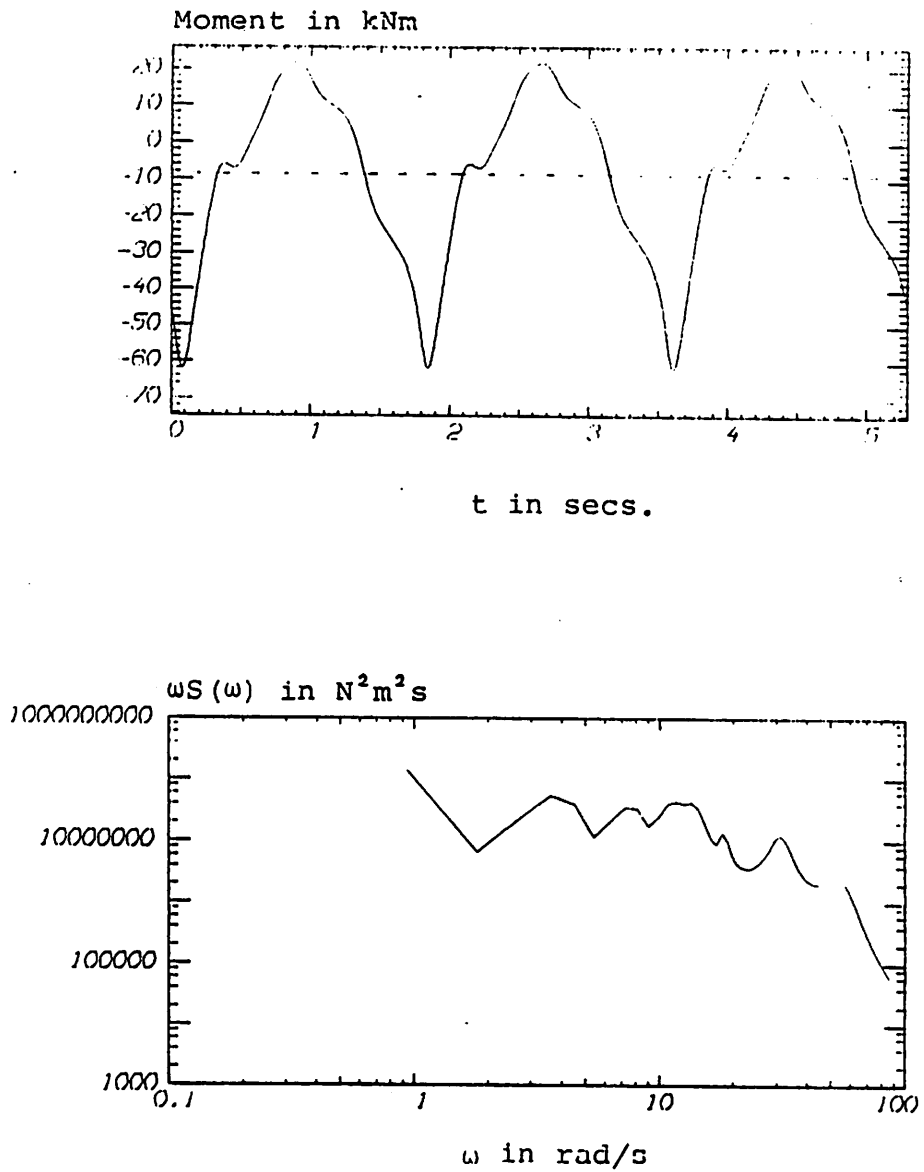

Fig. 4. Timehistory of the periodic part and power spectrum of the stochastic part of the flapwise bending moment at radius 1.6 m.



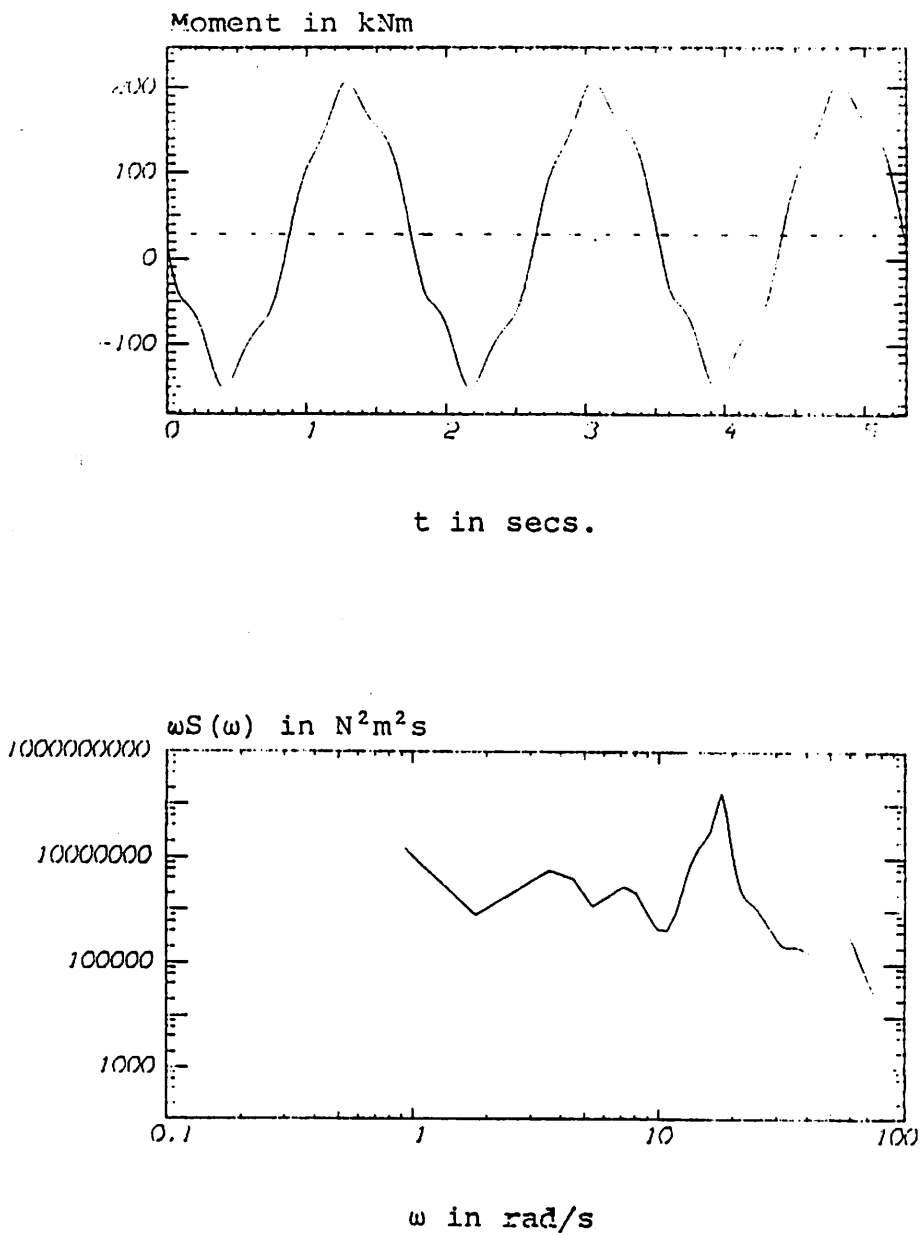

Fig. 5. Timehistory of the periodic part and power spectrum of the stochastic part of the chordwise bending moment at radius 1.6 m.

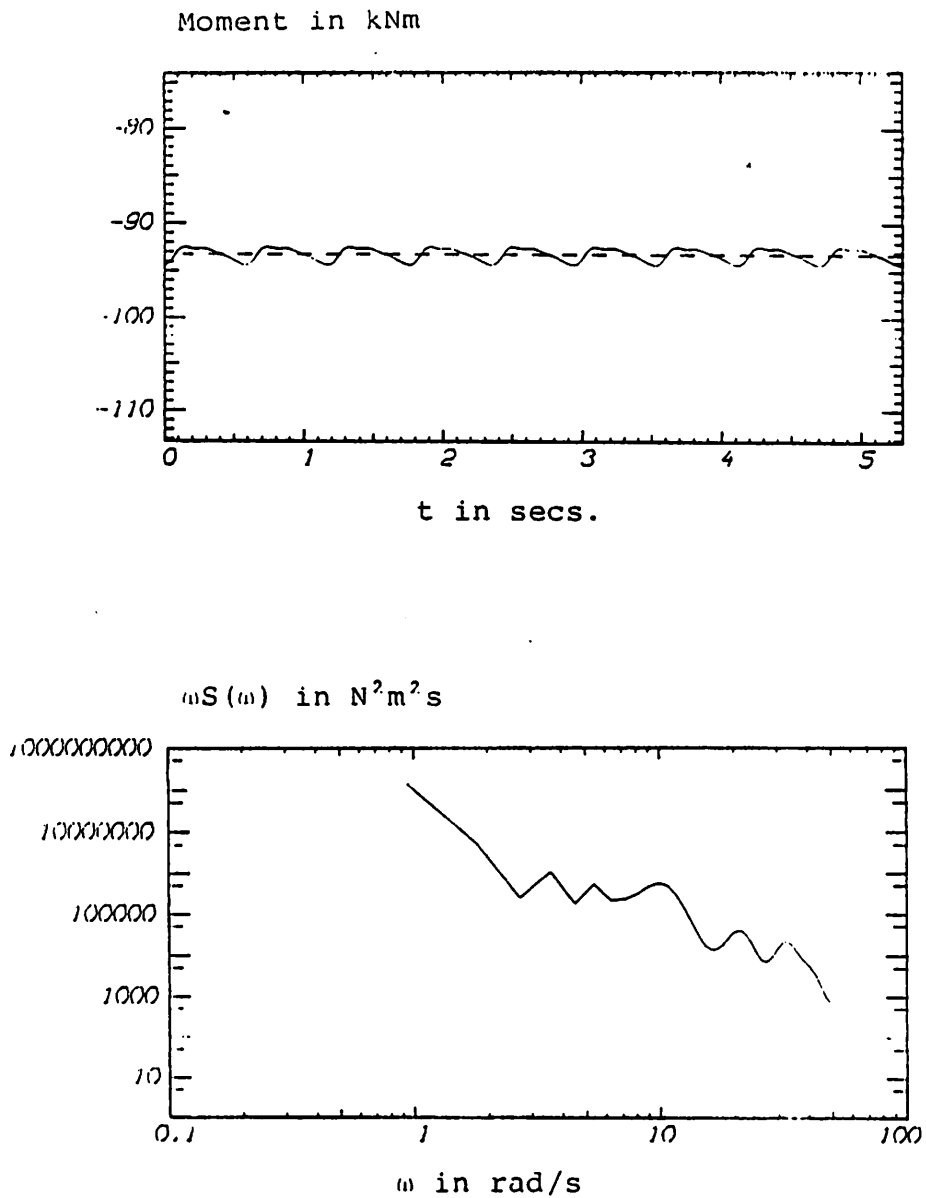

Fig. 6. Timehistory of the periodic part and power spectrum of the stochastic part of the drive moment on the shaft.

that fluctuations in the rotor thrust are almost solely caused by turbulence.

At the present time only a few comparisons have been made with measured data. However, in table 3 measured statistics from a recent 20 min measurement run from the Nibe-B turbine at a mean windspeed  $U = 10$  m/s. The three responses, flapwise and chordwise blade moment in the distance 1.6 m from the rotation axis and the axle drive moment are considered in terms of mean value, standard deviation and minimum and maximum values. The agreement with the model predictions using (25) and (26) for extreme value calculations is very good. In the Figs. 4, 5 and 6 the time history of the periodic part and the power spectrum of the stochastic part of the three responses from the model are shown at the mean wind speed  $U = 10$  m/s. The jagged appearance of the spectra is due to the limited resolution in the digital Fourier transform. The peaks in the spectra are caused by both the rotation in the turbulent windfield and the amplification at the modal frequencies.

Finally, it should be noted that the computer time for the calculations here referred to is less than 10 CPU min on a Burroughs B 7800 computer.

#### CONCLUDING REMARKS

A computer model of a wind turbine has been developed for lifetime prediction. Failure of the load carrying components can occur either by an accumulation of damage, material fatigue, or by a sudden exceedence of the ultimate stress by some stress response. The computer program is efficient, and preliminary comparisons indicate a good accuracy.

From test calculations it can be concluded that the turbulent excitation of a wind turbine plays an important role for both fatigue and extreme stress considerations. The proposed spectral approach to turbulence modelling applies for both considerations which speaks in favour of this method against the discrete gust approach.

## REFERENCES

- [1] Dugundji, J. and Wendell, J.H., "General Review of the MOSTAS Computer Code for Wind Turbines", M.I.T. Aerolastic and structures Research laboratory Report ASRL TR 197-1, July 1980.
- [2] Fabian, O., "A New Method for Aerolastic Analysis of Wind Turbines", AFM-report 81-06, Techn. University of Denmark, 1981.
- [3] Petersen, E.L. et al., "Windatlas for Denmark", Risø National Laboratory, Jan., 1981.
- [4] Madsen, P.H., Frandsen, S., Holley, W.E. and Hansen, J.C., "Dynamic Analysis of Wind Turbine Rotors for Lifetime Prediction", RISØ-report, 1983. (to appear).
- [5] Glauert, H., "Airplane Propellers", in Aerodynamic Theory, ed. Durand, W.F., Springer, Berlin.
- [6] Thresher, R.W., Holley, W.E. and Jafarey, N., "Wind Response Characteristics of Horizontal Axis Wind Turbines", Proc. Second DOE/NASA Wind Turbine Dynamics Workshop, Cleveland Ohio, Feb. 24-26, 1981.
- [7] Putter, S. and Manor H., "Natural Frequencies of Radial Rotating Beams", Journal of Sound and Vibration, Vol. 56, No. 2, 1978, pp 175-185.
- [8] Collins, J.D. and Thompson, W.T., "The Eigenvalue Problem for Structural Systems with Statistical Properties", AIAA Journal, Vol. 7, No. 4, 1969, pp. 642-648.
- [9] Jensen, N.O. and Frandsen, S., "Atmospheric Turbulence in Relation to Wind Generator Design", Proc. of the 2nd International Symposium on Wind Energy Systems, Amsterdam, 1978.

- [10] Kristensen, L. and Frandsen, S., "Model for Power Spectra Measured from the Moving Frame of Reference of the Blade of a Wind Turbine", Journal of Wind Engineering and Industrial Aerodynamics 10, No. 2, 1982.
- [11] Rosenbrock, H.H., "Vibration and Stability Problems in Large Wind Turbines Having Hinged Blades", Electrical Research Association Rep. C/T 113, 1955.
- [12] Lumley, J.L. and Panofsky, H.A., The Structure of Atmospheric Turbulence, Interscience Publ., John Wiley & Sons, New York, 1964.
- [13] Simiu, E. and Scanlan, R.H., Wind Effects on Structures, an Introduction to Wind Engineering, John Wiley & Sons, New York, 1978.
- [14] Engelund, F., Hydrodynamik, Den private Ingeniørfond, Danmarks Tekniske Højskole, 1968.
- [15] Miner, M.A., "Cumulative Damage in Fatigue", J. of Appl. Mech., Amer. Soc. of Mech. Engr., v. 12, pp. A 159 - A 164.
- [16] Matsuishi, M. and Endo, T., "Fatigue of Metals Subjected to Varying Stress", Proc. Japan Society of Mechanical Engineers, (in Japanese) n. 68-2, 1968, pp. 37-40.
- [17] Crandall, S.H. and Mark, W.D., Random Vibration in Mechanical Systems, Academic Press, New York, 1963.
- [18] Rice, S.O., "Mathematical Analysis of Random Noise, in Selected Papers on Noise and Stochastic Processes, ed. Wax, N., Dover, New York, 1954.
- [19] Wirsching, P.H. and Light, M.C., "Fatigue Under Wide Band Random Stresses", J. of Structural Div., Proc. A.S.C.E., v. 106, July 1980, pp. 1593-1607.

- [20] Rice, op. cit., 1954.
- [21] Madsen, op. cit., 1983.
- [22] Rice, op. cit., 1954.
- [23] Davenport, A.G., "Note on the Distribution of the Largest Value of a Random Function with Application to Gust Loading", Proc. Inst. Civil. Eng., London, Vol. 28, 1964, pp. 187+196.
- [24] Krenk, S., "First-Passage Times and Extremes of Stochastic Processes", in Thoft-Christensen, P. (ed.), Lecture on Structural Reliability, Institute of Building Technology and Structural Engineering, 1980, pp. 75-98.
- [25] Madsen, op. cit., 1983.
- [26] Davenport, op. cit., 1964.
- [27] Bathe, K.J., Wilson, E.L. and Peterson, F.E., SAP-IV, A Structural Analysis Program for Static and Dynamic Analysis of Linear Structural Systems.  
EERC Report No. 73-11, College of Engineering, University of California, Berkeley, June 1973.

TEETER EXCURSIONS OF A 2-BLADED HORIZONTAL AXIS WIND TURBINE  
ROTOR IN A TURBULENT VELOCITY FIELD

---

M B Anderson

Sir Robert McAlpine & Sons Limited  
40 Bernard Street  
London

A D Garrad and U Hassan

Wind Energy Group  
Taylor Woodrow Construction Limited  
309 Ruislip Road East  
Greenford  
Middlesex

Summary

A theoretical model is developed for predicting teeter excursions of the rotor of a horizontal axis wind turbine due to turbulence. A single degree of freedom model is used and it is assumed that the atmospheric turbulence is homogeneous and isotropic and that Taylor's frozen turbulence hypothesis is obeyed.

The effects of rotor size, Lock number, turbulence intensity and the introduction of a delta- $\beta$  hinge are examined. An approximate but rapid means of assessing the response of a given rotor to particular site conditions is described.

## 1. Introduction

On many two-bladed wind turbines the rotor is attached to the support structure via a "teeter hinge" that permits the rotor to exercise "see-saw" motion out of its plane of rotation thus allowing the reaction to the out-of-plane hub moments to be derived from the rotor inertia rather than the supporting structure.

On some wind turbines the hinge is not put at right angles to the rotor span but at an angle; this is usually referred to as a  $\delta_3$  hinge, see Figure 1. This variant of a teeter hinge introduces pitch-flap coupling as it changes the pitch of the blades as the rotor teeters and thus is equivalent to an aerodynamic spring. For a simple teeter hinge where  $\delta_3 = 0$  the rotor operates at resonance and hence the use of a non-zero  $\delta_3$  angle is useful since the addition of the aerodynamic spring moves the resonant frequency away from the operating point.

Anderson [1] considered the effect of tip speed ratio on teeter stability, Garrad [2] made a similar study that also included the influence of blade pitch angle. Some thirty years ago Rosenbrock [3] laid the foundations for the analytical treatment of wind turbines in a turbulent velocity field. The resurgence of wind energy has led to renewed interest in this work. Various authors Anderson [1], Connell [4] and Kristensen and Frandsen [5] have combined Rosenbrock's approach with the advantages of modern digital computers to allow more realistic representations of the turbulent fluctuations to be incorporated and cross-correlations to be treated. However, apart from Anderson [6] these papers have consisted of derivations of the basic



theory and have not attempted to translate this into information that is in a form accessible to designers of wind turbines. It is thought that the analysis and its interpretation presented here will provide a better understanding of the behaviour of a teetered rotor in a turbulent wind. It will also demonstrate that the spectral approach to such problems, which is more realistic than the discrete gust approach used in wind power applications, can give rise to informative data about machine behaviour.

## 2. Dynamic Model

A number of authors (Spera [7], Anderson [6] and Garrad [2]) have shown that a simple dynamic model of the rotor containing only one aeroelastic degree of freedom - the teetering motion - is sufficient for analysis of the rigid body motion of the rotor provided elastic considerations are not important. The following analysis will also adopt this approach.

The basic equation of motion is straightforward:

$$I \ddot{\beta} + I \omega^2 \beta = \int_{-R}^R r \frac{\partial F}{\partial r}(r, z) dr \quad (1)$$

Where  $\beta$  is the teeter angle;  $I$  the polar moment of inertia of the rotor about the teeter hinge;  $R$  the radius;  $\omega$  the rotational speed;  $r$  the local radius and  $F$  the out of plane force at radius  $r$ .

### 3. Aerodynamic Loads

Turbulence is made up of three velocity components: lateral, vertical and longitudinal. For a high tip speed ratio rotor ( $\lambda \gg 1$ ) it can be shown (Jensen and Frandsen [8]) that both the lateral and vertical components can be neglected with respect to the influence of the longitudinal component on the loads.

According to blade-element theory the blade loading distribution can be calculated from:

$$\frac{\partial \bar{F}(r, t)}{\partial r} = \frac{1}{2} \rho W^2 c C_{L\alpha} (\phi - \theta) \cos \phi \quad (2)$$

where  $W$  is the modulus of the apparent wind speed vector;  $c$  the chord at radius  $r$ ;  $\rho$  the density of the air;  $C_{L\alpha}$  the slope of the lift - angle of attack curve,  $\phi$  the angle between  $W$  and the plane of rotation and  $\theta$  the built-in twist. The profile drag has been neglected and it is assumed that the flow is quasi-steady.

The turbulent fluctuations,  $u(r, t)$  and the blade teetering will affect both  $W$  and  $\phi$ . It has been shown by de Vries [9] that for  $\lambda \gg 1$  their influence on  $W$  can be neglected with respect to their influence on  $\phi$  which results in the following variation in  $\phi$ :

$$\Delta \phi = \frac{u(r, t) - r \dot{\beta}}{\Omega r} \quad (3)$$

The pitch-flap coupling arising from the  $\frac{1}{3}$  hinge arrangement results in the following variation in  $\beta$  :

$$\Delta \beta = K_p \beta \quad (4)$$

where  $K_p = \tan \frac{\pi}{3}$ .

We may consider  $F(r, t)$  to be composed of a mean value  $\bar{F}(r)$  and a fluctuating component  $\Delta F(r, t)$ , then as  $\phi$  is relatively small when  $\lambda \gg 1$ ,  $\cos(\phi + \Delta\phi) \approx \cos \phi \approx 1$ ;  $W \approx \Omega r$ , it follows from equations (2), (3) and (4) that:

$$\Delta \left( \frac{\partial F(r, t)}{\partial r} \right) = \frac{1}{2} \rho \Omega r c C_{L\alpha} (u(r, t) - r\dot{\beta} - \Omega r K_p \beta) \quad (5)$$

and assuming that the blade chord,  $c$  is constant we obtain from equations (1), (3), (4) and (5)

$$\begin{aligned} \ddot{\beta} + \gamma \Omega \dot{\beta} + \Omega^2 (1 + K_p \gamma/3) \beta &= \\ \frac{\gamma}{4\Omega R^4} \left\{ \int_c^R |r| r u \, dr - \int_{-R}^c |r| r u \, dr \right\} \\ &= \frac{\gamma}{4\Omega R^4} \int_{-R}^R |r| r u \, dr \quad (6) \end{aligned}$$

where  $\gamma = 2\rho R^4 C_{L\alpha} c/I$  and is usually referred to as the Lock number (ratio of aerodynamic to inertial forces acting on a blade). Equation (6) describes the well known damped, forced oscillator and since the turbulent velocity fluctuations are stochastic the response,  $\beta$  will also be stochastic.

The power spectrum of the teeter angle,  $\theta$ , is therefore

$$S_{\theta}(\omega) = S_{\xi}(\omega) \left(1 - \gamma K_p / \beta\right)^{-2} / 4(\omega_c)^2 \quad (7)$$

where

$$|M(\omega)|^2 = \left[ \left(1 - (\omega/\omega_c)^2\right)^2 + \left(2\xi(\omega/\omega_c)\right)^2 \right]^{-1} \quad (8)$$

is commonly referred to as the mechanical transfer function,  $S_G(\omega)$

the power spectrum of the aerodynamic load fluctuations; here the natural frequency is given by:

$$\omega_c = \Omega \left(1 + \gamma K_p / \beta\right)^{1/2} \quad (9)$$

and the damping coefficient by:

$$\xi = \gamma / \left\{ 16 \left(1 + \gamma K_p / \beta\right)^{1/2} \right\} \quad (10)$$

The power spectrum of the aerodynamic load fluctuations can be expressed as:

$$S_G(\omega) = \left(\frac{\gamma}{4R\Omega}\right)^2 \int_{-1}^1 \int_{-1}^1 \kappa \kappa' |\kappa| |\kappa'| S_u(\omega, \kappa, \kappa') dx dx' \quad (11)$$

where  $S_u(\omega, \kappa, \kappa')$  is the cross spectrum of the longitudinal velocity fluctuations between points  $\kappa$  and  $\kappa'$ , on the rotor.

Note that the space variable  $r$  has been non-dimensionalised with respect to  $R$ :  $\kappa = r/R$ .

#### 4. Turbulence Model

$S_u(\omega, \lambda, \lambda')$  must be calculated in the moving frame of reference. Detailed derivation of this spectrum may be found in Rosenbrock [3], Anderson [1] and Kristensen and Frandsen [5].

In summary it is derived by transforming the single point longitudinal correlation function into the rotating frame of reference and then taking the Fourier transform. The correlation function may be obtained from the inverse Fourier transform of the single point spectrum. The main feature of this transformation is that it shifts the energy to higher frequencies and particularly to the rotor speed and its harmonics, hence the spectrum has large peaks at integer multiples of the rotational speed. Kristensen and Frandsen [5] and Fordham and Anderson [10] have shown that this approach produces reasonable agreement with experimental data.

Various spectra are available as the starting point for this process. Here we shall use the von Karman correlation function directly which is generally accepted as providing a good analytical representation of atmospheric turbulence.

It is realised that the turbulence is not homogeneous and isotropic but Fordham and Anderson [10] show that these limitations do not effect the results significantly. The effect of departure from isotropy near the ground has been considered by ESDU [11] and is allowed for by variation of turbulence intensity and scale with height and surface roughness. In order to define the von Karman spectrum, values for turbulence intensity ( $I_u$ ) and length scale ( $l$ ) must be supplied.

We require the spectrum of the teeter moment and hence we must integrate the individual components over the whole rotor as shown in equation (11).

### 5. Complete Model

$S_G(\omega)$  is now specified completing the description of the model in equation (7). Before investigating solutions to this equation it is convenient to introduce some further dimensionless parameters:

$$\eta = l/R$$

$$\xi = (1 + K_p \gamma/8)^{1/2}$$

$$s = \omega/\Omega$$

$$\lambda = R\Omega/\bar{U} \quad (\bar{U} \text{ is the mean wind speed})$$

$$I_u = \tau_u/\bar{U} \quad (\tau_u \text{ is standard derivation of turbulent velocity})$$

$$\chi = r/R$$

Using this nomenclature equation (7) may be rewritten as:

$$S_{\beta}^o(s) = \left( \frac{\gamma I_u}{4\lambda} \right)^2 \left[ (\xi^2 - s^2)^2 + (\gamma/8 s)^2 \right]^{-1} \\ \cdot \int_{-1}^1 \int_{-1}^1 \chi \chi' |\chi| |\chi'| \int_u^o(s, \chi, \chi') d\chi d\chi' \quad (12)$$

where the superscript o indicates that the argument of the function should be the non dimensional parameter s. It should be noted that

the velocity spectrum has been normalised to have unity variance.

It can be shown that the dimensional form of the teeter excursion spectrum can be recovered using the equation:

$$\int_{\beta} S(\omega) = \frac{2\pi}{\omega} \cdot S_{\beta}(\omega) \quad (13)$$

## 6. Level Crossing Analysis

It is now possible to compute further statistical characteristics that describe the teeter response of the rotor when subjected to turbulent loading. It is in this part of the analysis that previous authors have fallen short usually leaving their results in the form of spectra. Considerable physical insight may however be gained by considering amplitude statistics such as probability distributions.

For practical applications the probability of a given teeter angle being exceeded is required. This can conveniently be determined from level crossing analysis. A detailed description and derivation of the underlying theory to this analysis may be found in Bendat [12] and a brief outline is given in Appendix 1.

The application of level crossing techniques to the present analysis demonstrates that the number of times that the modulus of teeter angle

$|\beta|$  exceeds the value  $\theta$  in a period  $T$  is given by:

$$\bar{N}_{\theta} = \bar{N}_{\omega} T e^{-\theta^2 / 2 T_{\beta}^2} \quad (14)$$

where

$$\bar{N}_i = \frac{A}{\pi} \left\{ \frac{\int_0^{\infty} s^2 S_{\beta}^2(s) ds}{\int_0^{\infty} S_{\beta}^2(s) ds} \right\}^2 \quad (15c)$$

which is often termed the "apparent frequency" and

$$\sigma_{\beta}^2 = \int_0^{\infty} S_{\beta}^2(s) ds \quad (15d)$$

- the variance of the teeter angle excursions.

## 7. Results

The essence of the analysis is embodied in equation (12), from which it may be observed that the variance of  $\beta$ ,  $\sigma_{\beta}^2$  is linearly related to  $I_u^2$  - the square of the turbulence intensity.

$S_u^0$  is a fairly complicated function involving the Fourier transform of various Bessel functions with awkward arguments and hence the double integral is most easily handled numerically. A brief sensitivity analysis has shown that little improvement in accuracy is obtained by taking more than two blade stations (four stations on the whole rotor) and this number has been adopted for the following analysis.

In order to make this analysis as generally applicable as possible a range of site and machine characteristics has been considered. Typical roughness heights  $z_0$  lie between  $10^{-3}$  and  $10^{-2}$  m. Rotors with diameter



between 20 and 100 m have been considered and it has been assumed that a typical hub height for these machines will be equal to their diameter. This data gives rise to a range of length parameter  $\eta$  ( $= R/R_h$ ) of 3 to 9. Typical tip speed ratios have been taken to lie between 6 and 10, and blade Lock numbers between 3 and 20 have been considered.

Figure 2 shows some typical spectra. In order to show clearly how the output spectra are derived equations 7, 8 and 11 are plotted in the Figure. These curves demonstrate several important points. The input spectrum clearly exhibits peaks at multiples of the rotational speed. Since we are considering teetering motion only odd multiples are observed - this is explained in Appendix 2. The resonant nature of the teetering motion is also demonstrated.

The rotational sampling of the ambient turbulence concentrates the turbulent energy at multiples of  $\Omega$  and in particular at  $\Omega$  itself ( $\Omega = 1$ ). A peculiar characteristic of this dynamic system is therefore evident - the rotational motion both concentrates the available energy at the speed of rotation and causes the rotor to be resonant at the same frequency - in fact a teetering rotor provides a most efficient way of extracting the turbulent energy from the wind - unfortunately not a particularly desirable characteristic!

The variance of the teeter angle  $\sigma_\beta^2$  was calculated from equation (12) assuming unity turbulence intensity  $I_u$  and results are plotted in Figures 3 and 4 for the various values of  $\eta$ ,  $\gamma$  and  $\lambda$ . It is evident from Figure 3 that the variance of  $\beta$  increases slowly with Lock number

$\gamma$  but that its dependence is fairly weak. The Lock number is often considered to represent the damping of the rotor. It might therefore be expected that increasing  $\gamma$  would reduce  $\tilde{\tau}_\beta^2$ , however re-examination of equation (1) and the definition of  $\gamma$  reveals that the moment of inertia of the rotor plays an important part in both the stiffness and the damping of the system and that changing I (and hence  $\gamma$ ) will produce opposing changes in the stiffness and damping which accounts for the apparent insensitivity of  $\tilde{\tau}_\beta^2$  to changes in  $\gamma$ . It is also evident from Figure 4 that  $\tilde{\tau}_\beta^2$  reduces with increasing  $\lambda$ . Reference to equation (3) explains this trend. Recalling that  $1/\lambda = \bar{u}/R\Omega$  it is evident that for a given value of  $I_u$  that  $\Delta\phi$  varies as  $1/\lambda$  hence an increase in  $\lambda$  will reduce  $\tilde{\tau}_\beta^2$ .

The results presented in Figure 3 have been replotted in Figure 4 to show more clearly how  $\tilde{\tau}_\beta^2$  depends on the length parameter  $\eta$ . A large value of  $\eta$  indicates that the turbulence length scale is large compared with the rotor size. Since teetering motion is sensitive to differential loading on either blade it is to be expected that large eddies will have less effect than smaller ones.

Figure 5 shows how  $\tilde{\tau}_\beta^2$  varies with  $\delta_3$ . These results are much as expected - the effect of the  $\delta_3$  angle is to remove the system from resonance and hence a reduction in  $\tilde{\tau}_\beta^2$  is anticipated. Negative  $\delta_3$  is undesirable for other dynamic reasons but in the present context reduction in  $\tilde{\tau}_\beta^2$  is achieved for both positive and small negative values. Large enough negative values will however produce instability.

Reference to Figure 2 shows that the teeter spectrum has the majority of its energy centred at  $\dot{\gamma} = 1$  i.e. the rotational speed. It is therefore anticipated that the apparent frequency of the response given by equation (14) will be very near to twice this value, numerical results confirmed this and in fact for the range of parameters considered here  $\bar{N}_0$  was found, to all intents and purposes to be equal to twice the rotational speed - again demonstrating the ability of the teetering system to concentrate energy at this frequency.

The fact that  $\bar{N}_0$  is virtually constant and the nature of the response indicated in Figure 2 suggests that an approximate semi-analytical solution could be obtained for the teeter response.

For high Lock numbers the resonance is fairly gentle and some way removed from the peak in the input spectrum. Under these conditions a reasonable approximation to the output spectrum should be obtained by assuming that the transfer function has a constant value over the range of frequency for which the peak in the input spectrum occurs.

Under these assumptions equation (12) reduces to:

$$S_{\beta}^o(s) = \frac{4I_u^2}{(1+K_p^2)\lambda^2} \int_{-1}^1 \int_{-1}^1 S_u^c(s) x x' |x|/|x'| dx dx' \quad (16)$$

Note that this expression is independent of  $\gamma$ .

Since the apparent frequency  $\bar{N}_0$  is virtually independent of the rotor characteristics and site conditions it is evident from equation (14)

that the level crossing analysis only requires knowledge of  $\bar{T}_3$ . It is well known that the variance of a distribution may be calculated either by integrating the spectrum as shown in equation (15b) or by evaluating the autocorrelation fraction at zero time lag. Reference to equation (16) shows that the autocorrelation of  $\beta$  may be obtained from the longitudinal correlation of the wind velocity ( $\rho_{uu}$ ) suitably integrated over the rotor. At zero time lag ( $\tau = 0$ )  $\rho_{uu}(\tau)$  is only a function of  $\eta$  and hence the double integral in equation (16) is also a function of  $\eta$  alone.

A detailed derivation of  $\rho_{uu}$  is given by Fordham and Anderson [10] and Kristensen and Frandsen [5] and will not be reproduced here, the result may simply be quoted as: . . .

$$\rho_{uu}(0) = \frac{2}{\Gamma(1/3)} \cdot \left(\frac{2}{3}\right)^{1/3} \left\{ K_{1/3}\left(\frac{2}{3}\right) - \frac{1}{4} \left(\frac{2}{3}\right) K_{2/3}\left(\frac{2}{3}\right) \right\} \quad (17)$$

where

$$\xi^2 = \frac{1}{a^2 \eta^2} (x^2 + x'^2 - 2xx' \cos \theta_s) , \quad (18)$$

$\Gamma$  is the Gamma function,  $K_n$  is a modified Bessel function of the second kind of order  $n$ ,  $a$  is a numerical constant and  $\theta_s$  may take two values:  $\theta_s = 0$  if  $x$  and  $x'$  are on the same blade and  $\theta_s = \pi$  if they are on different blades.

Let us denote the variance of the double integral in equation (16) as

$\sigma^2(\eta)$  which we may now evaluate as:

$$\sigma^2(\eta) = \int \int_{-\infty}^{\infty} f(x) f(x') |x-x'| dx dx' \quad (17)$$

Consideration of equations (17), (18) and (19) shows that  $\sigma^2$  is a function of  $\eta$  alone.  $\sigma^2(\eta)$  is easily evaluated and is plotted against  $\eta$  in Figure 6. Using this function a simple expression for

$\sigma_p^2$  may be obtained:

$$\sigma_p^2 = \frac{4 I_u^2}{(1+k_p^2)} \frac{1}{\lambda^2} \sigma^2(\eta) \quad (20)$$

Values of variance calculated from (20) are plotted as dashed lines on Figures 3, 4 & 5 and appear to be in reasonable agreement at least as an upper limit to expected values. Derivation of (20) assumed that the Lock number was large - this limitation is clearly demonstrated by the Figures.

In order to provide a physical interpretation the level crossing technique may now be applied to the variance data. Equation (14) can be recast slightly to give the number of times that a particular teeter angle is exceeded per revolution:

$$\bar{N}_\theta = 2 \exp(-\theta^2 / 2\sigma_p^2)$$

or

$$\bar{N}_{\theta/2} = \exp(-\theta^2 / 2\sigma_p^2) \quad (21)$$

This analysis may be condensed, subject to the approximations involved in deriving equation (16), into two sets of curves - Figure 6 that shows  $\tilde{\sigma}_\beta^2(\eta)$  and Figure 7 that shows plots of  $\tilde{\sigma}_\beta^2 / 2$  for various values of  $\tilde{\sigma}_\beta^2$ . These two Figures provide a rapid method of assessing the response of a teetered rotor to atmospheric turbulence.

It can be seen from Figure 7 that appreciable teeter angles may result from turbulent excitation. As an illustration let us consider two numerical examples.

a) Large wind turbine

The following parameters will be used to describe a typical large turbine:

$$\eta = 3, \quad \lambda = 6, \quad \gamma = 3, \quad I_u = 10\%$$

First let us analyse the response using Figure 3 whence

$$\begin{aligned} \sigma_\beta^2 &= 0.56 \times 10^{-2} \text{ radians}^2 \text{ for unity turbulence intensity. So for} \\ I_u = 10\% \quad \sigma_\beta^2 &= 0.56 \times 10^{-4} \text{ radians}^2 \\ &= 0.186 \text{ degrees}^2 \end{aligned}$$

Adopting the approximate approach of equation (20) we have

$$\tilde{\sigma}_\beta^2 = 0.33 \text{ (degrees)}^2.$$

Now that  $\tilde{\sigma}_\beta^2$  has been calculated Figure 8 or equation (21) may be used to estimate the number of exceedances per revolution:

$e^{\circ}$ 
 $\bar{N}_e$ 

## Number of Exceedances

	Approximate	Exact
1	0.440	0.136
2	$4.7 \times 10^{-3}$	$4.2 \times 10^{-5}$

b) Small turbine

The following parameters describe a typical small turbine:

$$\eta = 6, \quad \lambda = 10, \quad \gamma = 10, \quad I_u = 10\%$$

Using precisely the same reasoning as in (a) we obtain the following results:

 $e^{\circ}$ 
 $\bar{N}_e$ 

	Approximate	Exact
1	$6.1 \times 10^{-3}$	$1.0 \times 10^{-3}$
2	$1.735 \times 10^{-10}$	$1.823 \times 10^{-13}$

These values can be converted into more useful parameters. For example given the relevant operating conditions it is possible to estimate the number of exceedances per day which, when used in conjunction with teeter excursions due to steady state excitation could be used to calculate the number of stop impacts.

Let us assume that the turbines operate for 70% of the time and rotate at 20 and 80 rpm. Using the "exact" values calculated above we have:

	Angle to be exceeded	Number of exceedances per rev	Number of revs per day	Number of exceedances per day
	$\epsilon^\circ$	$\bar{N}_\epsilon$		
Large turbine	1	0.136	20160	2742
	2	$4.2 \times 10^{-5}$		0.85
Small turbine	1	$10^{-3}$	80640	81
	2	$1.82 \times 10^{-13}$		$1.5 \times 10^{-8}$

## 8. Conclusions

The following general conclusions may be drawn from the analysis presented in this paper.

1. The response of a teetered rotor may be fully described by four dimensionless parameters:
  - . the ratio of the turbulence length scale to the rotor radius  
( $\eta$ )
  - . the tip speed ratio ( $\lambda$ )
  - . the Lock number ( $\gamma$ )
  - . the turbulence intensity ( $I_u$ )
  - . the  $\epsilon_3$  angle



2. The standard deviation of teeter angle

- . is directly proportional to  $I_u$
- . decreases with  $\lambda$
- . decreases with  $\sigma$
- . is only very weakly dependent on Lock number
- . is decreased by positive  $\delta_3$  and decreased by small negative  $\delta_3$  angles.

3. Under some conditions turbulence may produce significant teeter excursions.

An approximate, but general method for rapid determination of teeter response has been described.

Acknowledgement

The work described in this report was supported by both the UK Department of Energy and Taylor Woodrow Construction Limited whose permission to publish this paper is acknowledged.

Nomenclature

- $c$  = blade chord  
 $C_{L\alpha}$  = slope of lift curve  
 $F$  = aerodynamic loading  
 $I$  = rotor inertia about teeter hinge  
 $K_p$  =  $\tan \delta_3$   
 $l$  = turbulence length scale  
 $n$  = subscript denoting fractional order of Bessel functions  
 $|M(\omega)|^2$  = mechanical transfer function  
 $\bar{N}_0$  = apparent frequency  
 $\bar{N}_\theta$  = number of crossings of level  $\theta$  per unit time  
 $\bar{N}_\theta^+$  = number of crossings of level  $\theta$  in the positive direction per unit time  
 $r$  = local radius  
 $R$  = tip radius  
 $s$  = non dimensional frequency  
 $S_p$  = power spectrum of teeter angle  
 $S_u$  = power spectrum of wind velocity fluctuations  
 $u$  = wind velocity fluctuations

- $\bar{u}$  = mean wind velocity  
 $W$  = relative velocity  
 $x$  = non-dimensional blade radius ( $= r/R$ )  
 $\beta$  = teeter angle  
 $\gamma$  = Lock number  
 $\delta$  =  $(1 + K_p \gamma / 8)^{\frac{1}{2}}$   
 $\delta_3$  = teeter hinge angle w.r.t. blade span  
 $\eta$  =  $l/R$   
 $\theta$  = arbitrary teeter angle  
 $\theta_t$  = blade pitch angle  
 $\theta_s$  = angular separation of two points on the rotor  
 $\lambda$  = tip speed ratio  
 $\xi$  = damping ratio  
 $\sigma^2$  = variance  
 $\rho$  = air density  
 $\rho(\tau)$  = longitudinal correlation function  
 $\phi$  = flow angle  
 $\omega$  = frequency radians  $s^{-1}$

$\omega_0$  = natural frequency

$\mathcal{L}$  = angular velocity of rotor

### Superscripts

o Denotes a function expecting  $s$  as its argument

•  $d/dt$

- time average

References

1. Anderson, M B 'The interaction of turbulence with a horizontal axis wind turbine', Proc. of the 4th BWEA Wind Energy Conference, Cranfield, UK, March (1982), pp 104-118.
2. Garrad, A D 'The prediction of teeter excursions on a horizontal axis wind turbine', Proc. of the 4th BWEA Wind Energy Conference, Cranfield, UK, (1982), pp 86-95.
3. Rosenbrock, H H. 'Vibration and stability problems in large wind turbines having hinged blades', Electrical Research Association Rep. C/T 113 (1955).
4. Connell, J R 'The spectrum of wind speed fluctuations encountered by a rotating blade of a wind energy conversion system: observation and theory', Battelle Pacific Northwest Laboratory Report PNL 4983. (1981).
5. Kristensen, L and Frandsen, S 'Model for Power Spectra of the Blade of a Wind Turbine Measured from the Moving Frame of Reference', Journal of Wind Engineering and Industrial Aerodynamics 10, No. 2, (1982).
6. Anderson, M B 'A comparison of hinged, teetered and hingeless rotors', Proc. of the 4th BWEA Wind Energy Conference, Cranfield, UK (1982), pp 56-74.

7. Spera, D A. 1975 'Structural analysis of wind turbine rotors for NSF-NASA Mod 0 Wind Power System', NASA TM X-3198.
8. Jensen, N O and Frandsen, S 'Atmospheric turbulence in relation to wind generator design', Proc. of the 2nd International Symposium on Wind Energy Systems, Amsterdam (1978).
9. de Vries, O. 'Fluid dynamic aspects of wind energy conversion', AGARD-AG-243,(July, 1979).
10. Fordham, E J and Anderson, M B 'An analysis of results from an atmospheric experiment to examine the structure of the turbulent wind as seen by a rotating observer', Proc. of the 4th BWEA Wind Energy Conference, Cranfield, UK, (1982), pp 162-179.
11. ESDU Data Item 74031 'Characteristics of Atmospheric Turbulence Near the Ground', March 1971.
12. Bendat, J S 'Principles and Applications of Random Noise Theory', John Wiley and Son, New York, 1958.

Captions for Figures

1. A teeter hinge with  $\delta_3$  inclination
2. Typical input and output spectra plotted in arbitrary units.
3. Variation of teeter variance  $\sigma_\beta^2$  with Lock number  $\delta$ . ( $\beta$  measured in radians)
 

(a)  $\delta = 3, \lambda = 6, \eta = 3$ ; (b)  $\delta = 10, \lambda = 6, \eta = 3$

—— Exact      — — — — Equation (20)
4. Variation of teeter variance  $\sigma_\beta^2$  with size parameter  $\eta$ . ( $\beta$  measured in radians)
 

—— Exact      — — — — Equation (20)
5. Variation of teeter variance  $\sigma_\beta^2$  with  $\delta_3$  angle. ( $\beta$  measured in radians)
 

—— Exact      — — — — Equation (20)
6. Evaluation of equation (19)
7. Expected number of exceedances per revolution as a function of arbitrary teeter angle  $\theta$ , ( $\theta$  and  $\beta$  measured in degrees).

Appendix 1A Summary of Level Crossing Theory

Let  $P(\beta, \dot{\beta})$  be the joint probability density function between teeter angle  $\beta(t)$  and its derivative. By definition

$$P(\theta, \dot{\theta}) d\theta d\dot{\theta} = \text{Prob}[\theta < \beta < \theta + d\theta \text{ and } \dot{\theta} < \dot{\beta} < \dot{\theta} + d\dot{\theta}]$$

This represents the fraction of the total time that  $\beta$  spends in the interval  $d\theta$  with a velocity between  $\dot{\theta}$  and  $\dot{\theta} + d\dot{\theta}$ . Since  $d\dot{\theta}$  is negligible relative to  $\dot{\theta}$ , the velocity can be assumed to be  $\dot{\theta}$ .

If  $\tau$  is the crossing time for a velocity  $\dot{\theta}$  in the interval  $d\theta$ , then

$$\tau = \frac{d\theta}{|\dot{\theta}|}$$

The absolute value of  $\dot{\theta}$  is used because the teeter angle may cross the level  $\theta$  from either direction. The expected number of crossings of  $\beta(t)$  through the interval  $\theta$  to  $\theta + d\theta$  for a given value of velocity  $\dot{\theta}$  is

$$\frac{P(\theta, \dot{\theta}) d\theta d\dot{\theta}}{\tau} = |\dot{\theta}| P(\theta, \dot{\theta}) d\theta$$



By integrating this expression with respect to  $\dot{\theta}$ , the total number of crossings per unit time through the interval  $\theta$  to  $\theta+d\theta$  is obtained:

$$\bar{N}_\theta = \int_{-\infty}^{\infty} |\dot{\theta}| P(\theta, \dot{\theta}) d\dot{\theta} \quad (1)$$

Assuming that  $\beta(t)$  and  $\dot{\beta}(t)$  are mutually independent and have normal distributions with zero means, the joint probability density function is the product of the individual probability distributions, and we obtain:

$$P(\theta, \dot{\theta}) = \frac{1}{2\pi \sigma_\beta \sigma_{\dot{\beta}}} \exp \left[ - \left( \frac{\theta^2}{2\sigma_\beta^2} + \frac{\dot{\theta}^2}{2\sigma_{\dot{\beta}}^2} \right) \right]$$

Using this value for  $P(\theta, \dot{\theta})$  equation (1) is integrated to yield

$$\bar{N}_\theta = \frac{1}{\pi} \left( \frac{\sigma_{\dot{\theta}}^2}{\sigma_\beta^2} \right)^{1/2} \exp \left[ - \theta^2 / 2\sigma_\beta^2 \right]$$

where

$$\sigma_\beta^2 = \int_0^\infty S_\beta(n) dn$$

and

$$\sigma_{\dot{\beta}}^2 = 4\pi^2 \int_0^\infty n^2 S_\beta(n) dn$$

The expected number of crossings per unit time when  $\theta = 0$  is

$$\bar{N}_0 = \frac{1}{\pi} \left( \frac{\sigma_{\dot{\theta}}^2}{\sigma_{\beta}^2} \right)^{1/2} = 2 \left[ \frac{\int_0^{\infty} n^2 S_{\beta}(n) dn}{\int_0^{\infty} S_{\beta}(n) dn} \right]^{1/2}$$

and is often termed the "apparent frequency" of the data series. Hence

$$\bar{N}_{\theta} = \bar{N}_0 e^{-\theta^2/2\sigma_{\beta}^2} \quad (2)$$

The number of times that the teeter angle exceeds the value  $\theta$  in the positive direction in a period  $T$  is given by

$$\bar{N}_{\theta}^+ = \frac{1}{2} \bar{N}_0 T e^{-\theta^2/2\sigma_{\beta}^2} \quad (3)$$

Appendix 2Harmonic content of teeter loads

Let the blade be loaded periodically by  $P(\psi) = \sum_{n=1}^{\infty} A_n \cos n\psi$  where  $\psi = \Omega t$  is azimuth angle. The teeter moment arises due to differential loading across the rotor and hence is given by

$$\begin{aligned}
 M(t) &= P(\psi) - P(\psi + \pi) \\
 &= \sum_{n=1}^{\infty} A_n (\cos n\psi - \cos n(\psi + \pi)) \\
 &= \sum_{n=1}^{\infty} A_n (1 - \cos n\pi) \cos n\psi \\
 &= \sum_{n=1}^{\infty} A_n (1 - (-1)^n) \cos n\psi \\
 &= A_1 \cos \psi + A_3 \cos 3\psi + \dots
 \end{aligned}$$

$M(t)$  therefore contains only odd harmonics of the rotor speed.

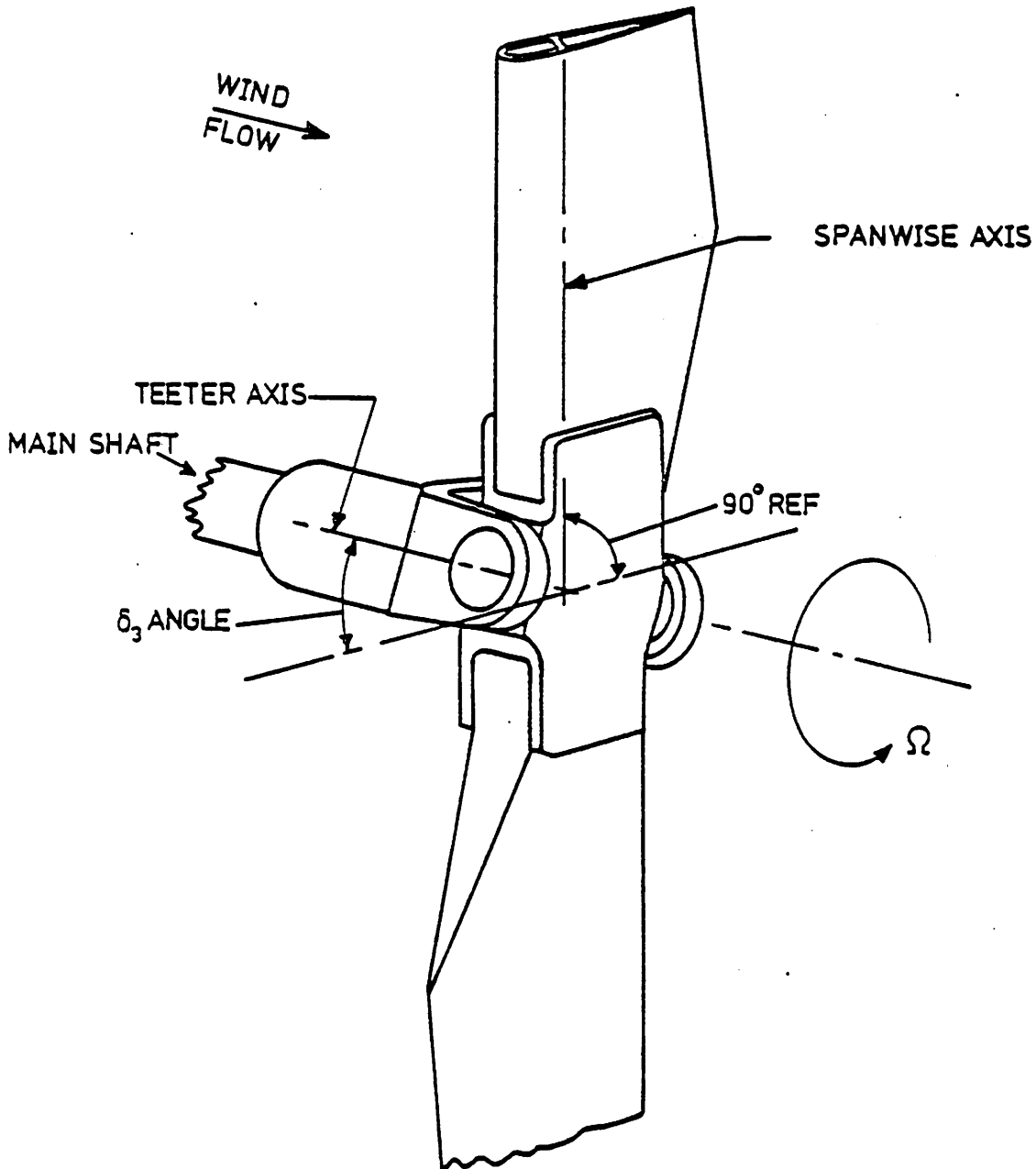

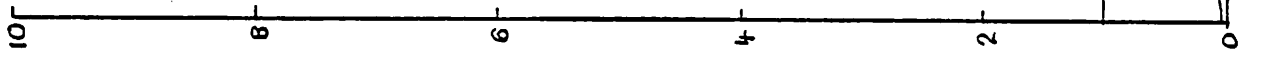

(a)

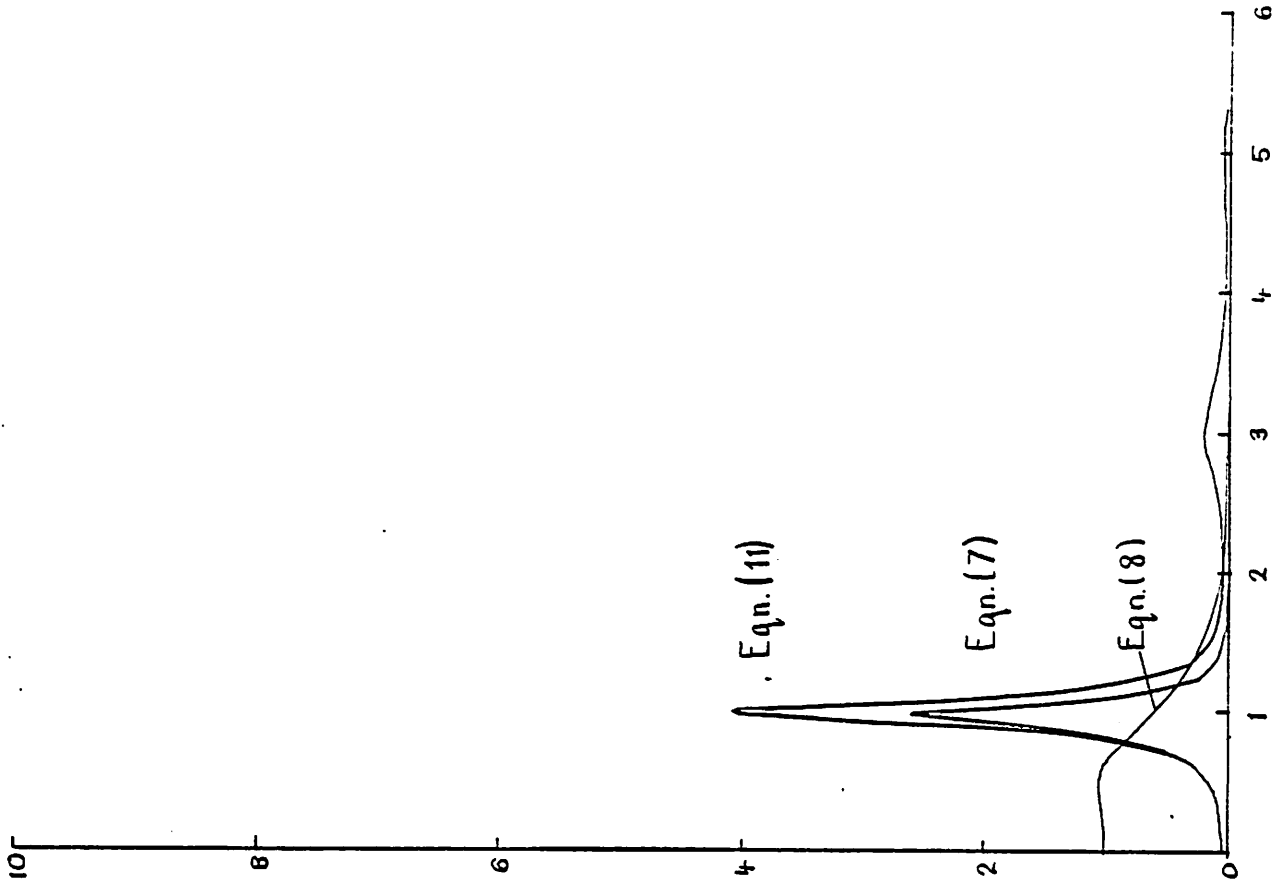

(b)

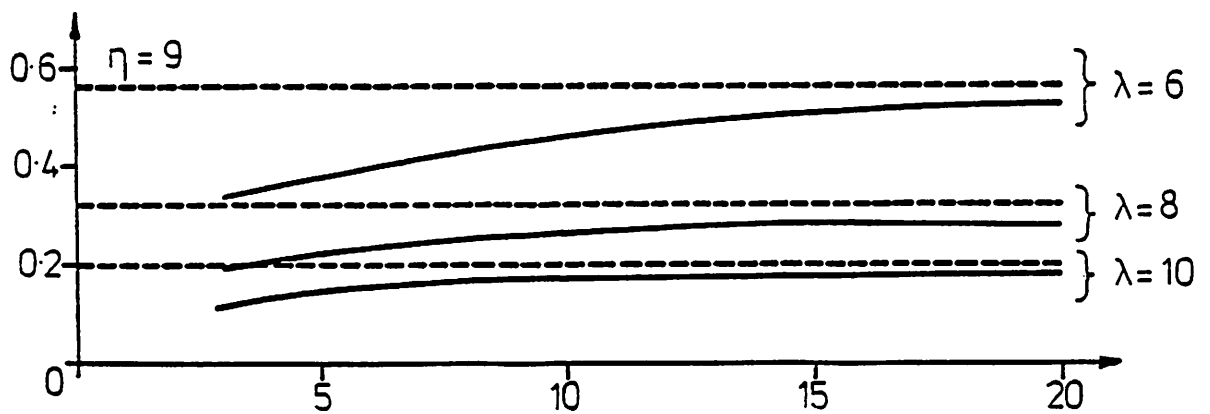
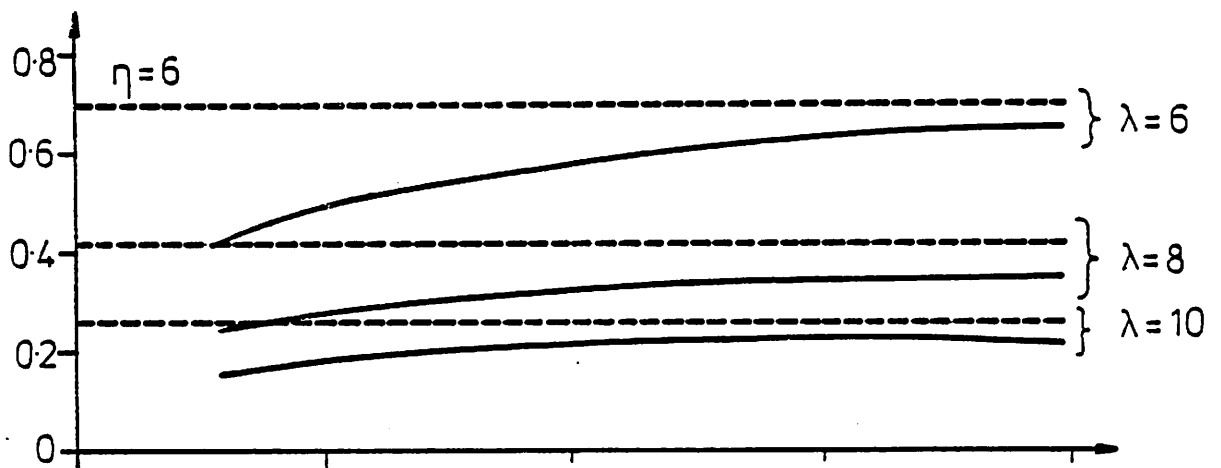
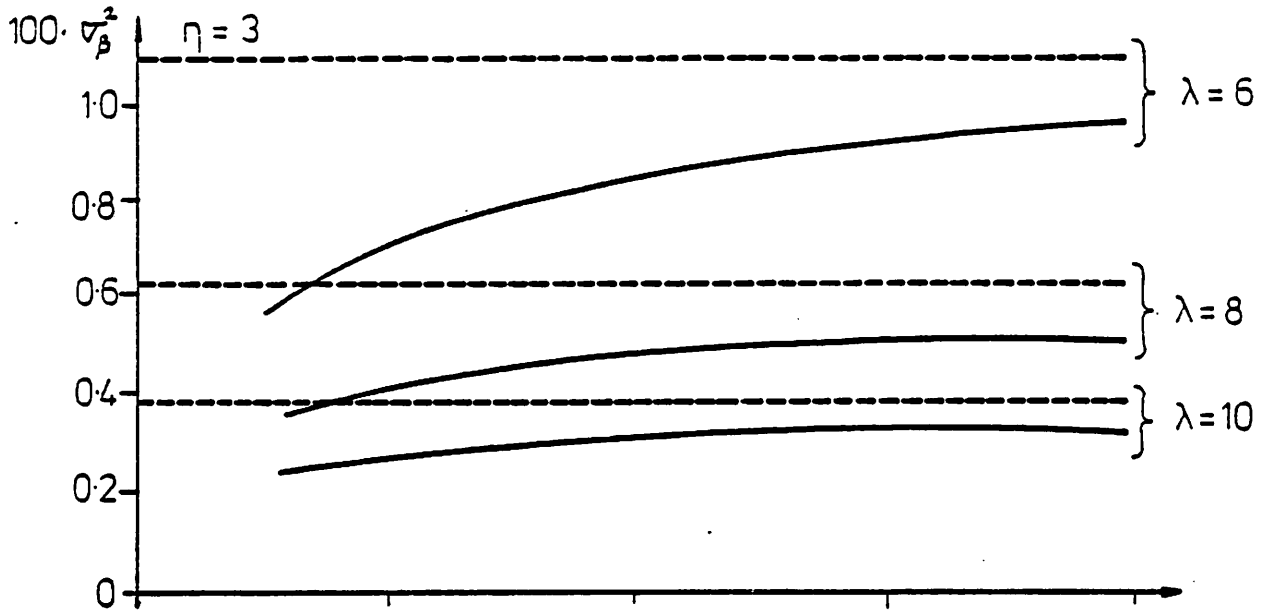

Lock Number  $\gamma$

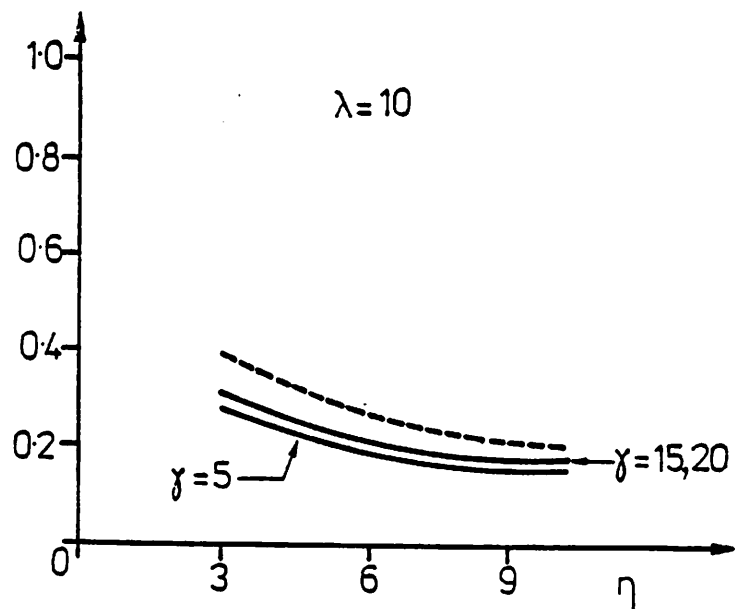
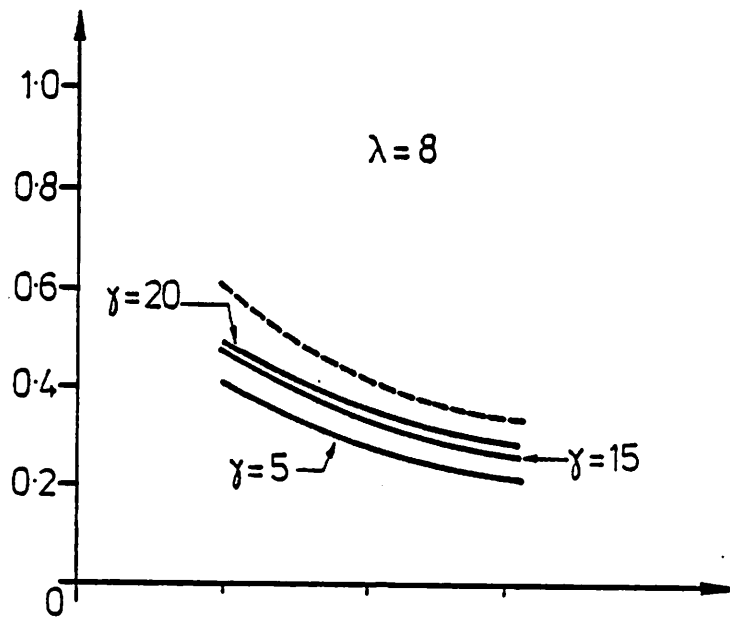
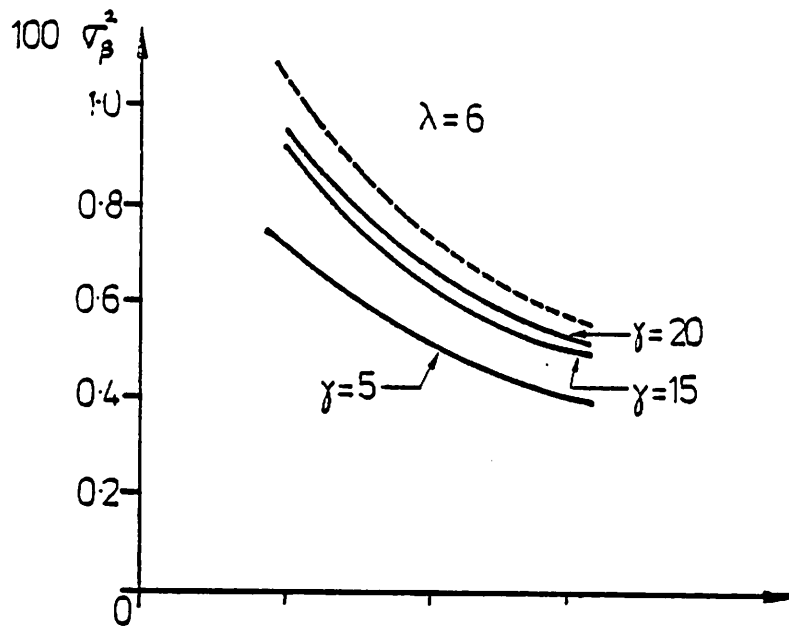

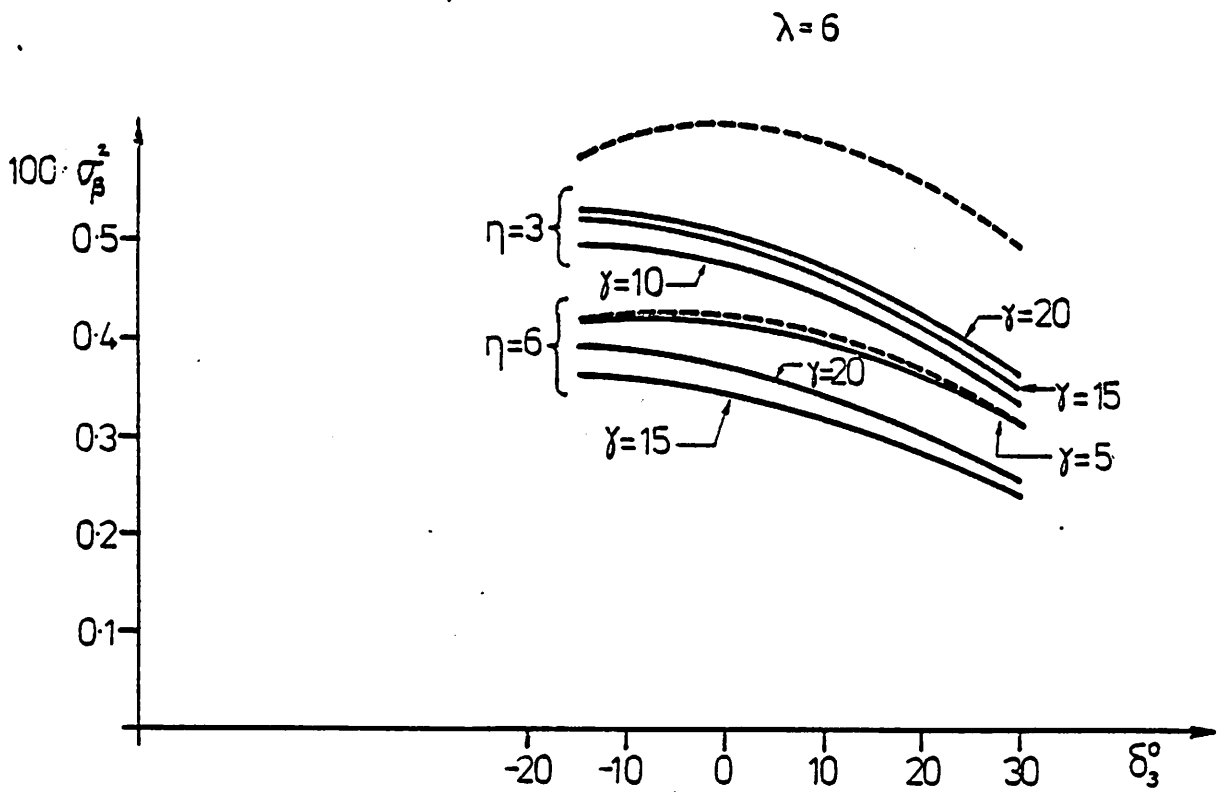
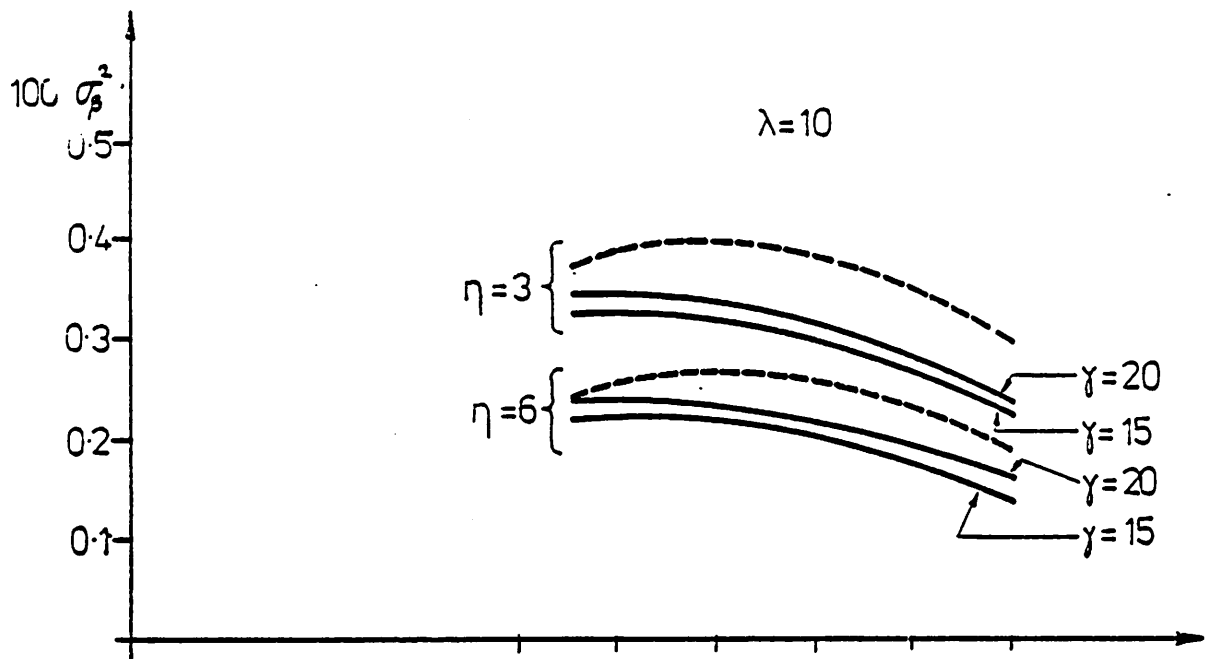



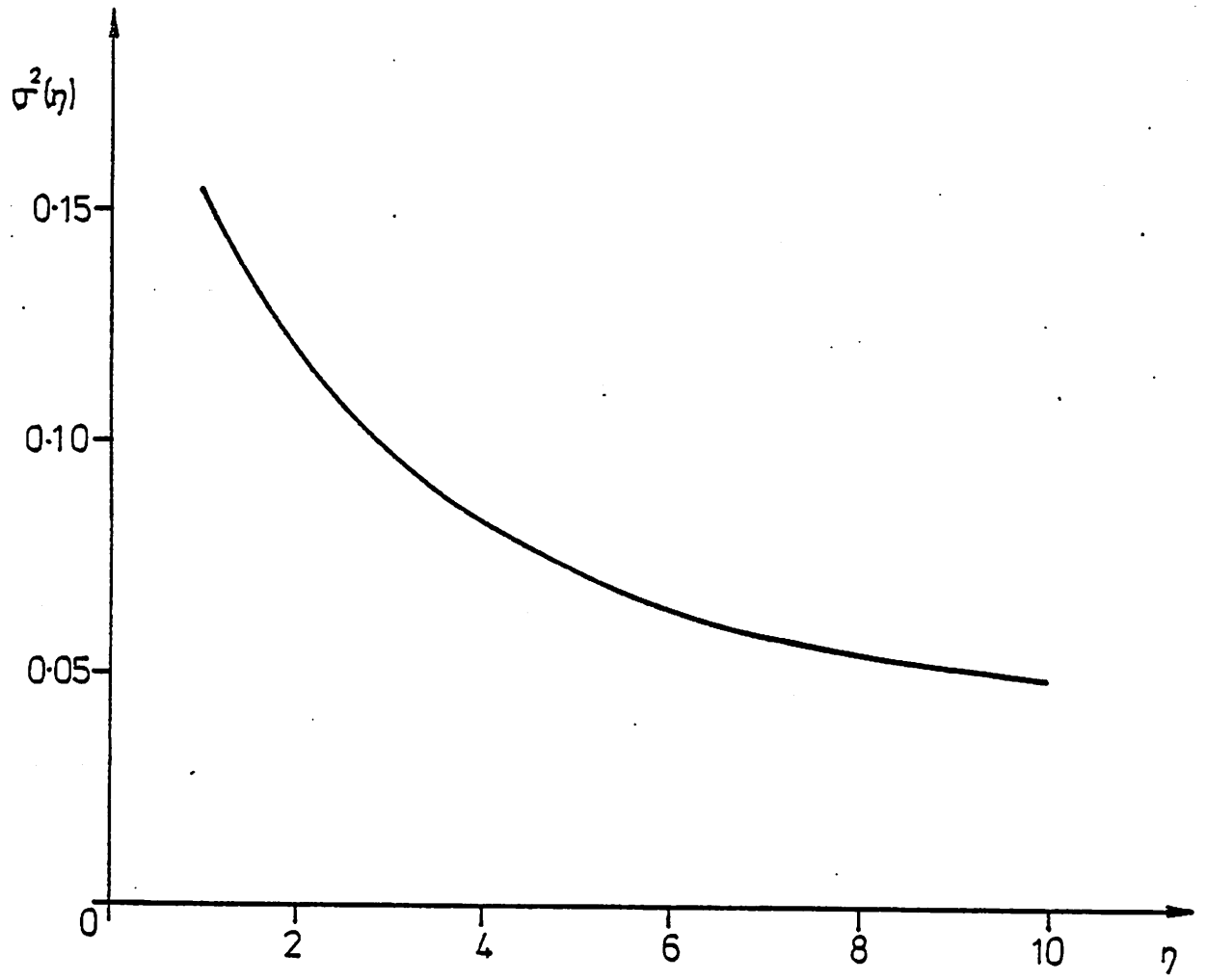

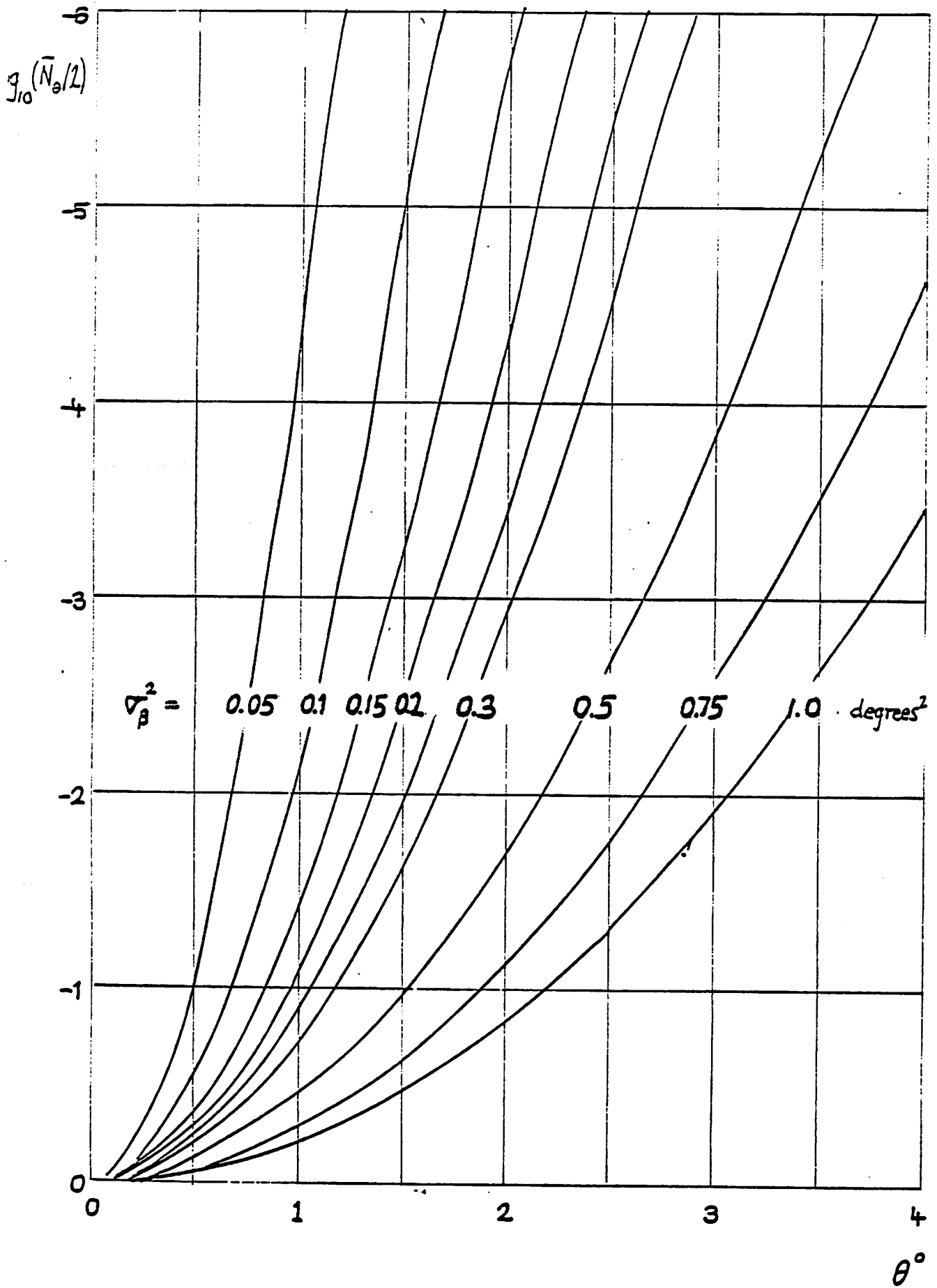

## TURBULENCE INDUCED LOADS IN A WIND TURBINE ROTOR

A.D. Garrad and U. Hassan  
Wind Energy Group  
Greenford House  
309 Ruislip Road East  
Greenford  
Middlesex  
U.K.

### Abstract

The response of a three degree of freedom model of a 2-bladed teetered horizontal axis wind turbine excited by wind turbulence is reported. It is demonstrated that turbulence induced cyclic loads may be comparable to deterministic loads in the flatwise direction. Shortcomings and difficulties in the analysis are discussed.

### Introduction

What is the rise time for a wind gust? What is its maximum velocity? Are "down gusts" different in shape to "up gusts"? All these, and many more questions, arise when the stochastic behaviour of the wind is modelled as a series of discrete gusts. The answer to each question is that we don't know. A discrete gust is a useful concept for understanding the dynamic behaviour of the system that it excites, but it does not aid understanding of the wind itself.

For many years the frequency domain approach to wind loading on buildings has been recognised as the most desirable approach for analysing dynamically active structures, see for example Wyatt (1). For this type of structure methods exist for prediction of normal and extreme loads and these may, in principle, be applied to the analysis of wind turbine loads. There are, however, some important differences between stationary structures and wind turbine systems that tend to complicate this already relatively complex type of analysis:

- The blades that rotate through the turbulent wind
- The dynamic and aerodynamic coupling between the various modes of vibration
- The periodic terms in the equations of motion that describe a tower - rotor system

These three characteristics make the application of spectral techniques to the analysis of wind turbines considerably more complex than the equivalent task for stationary structures or indeed fixed wing aircraft, and they may well explain with good reason the fact that spectral analysis has been slow to find application in this technology, and also why it is still some way from being available as a standard design tool.

In fact Rosenbrock (2) laid the foundation for the analytical treatment of wind turbines in a turbulent velocity field some thirty years ago. The resurgence of wind energy has led to renewed interest in this work and various authors - Kristensen and Frandsen (3), Anderson (4) and Connell (5) have rediscovered the Rosenbrock approach and applied it together with the modern computing techniques to produce a reasonable description of the turbulence field

encountered by a rotating wind turbine blade. It is not the intention of this paper to re-iterate these analyses but rather to demonstrate how the approach described by them may be used to assess the importance of turbulence on the loading of a wind turbine rotor, and to draw attention to the difficulties - some still unresolved - that are encountered in the process.

### Dynamic Model

This paper addresses the problem of performing a dynamic analysis of a two-bladed, teetered horizontal axis wind turbine rotor excited by a turbulent wind. The results of such an analysis may take the form of displacement, velocity, acceleration or load spectra and their associated characteristics. Here they will be limited to teeter excursions and flatwise blade loads. The analysis of teeter excursions alone has already been treated in some detail by Anderson, Garrad and Hassan (6) and hence will only be of passing interest here. Estimates of fatigue damage and extreme loads can result from the analysis of dynamic response to turbulent wind. In the context of fatigue, edgewise blade loads are dominated by gravitational effects and hence turbulent excitation is not considered to be of significance. For this reason the 3 modal degrees of freedom used here are limited to the flatwise direction.

The dynamic model is derived from that given by Garrad (7) omitting the support structure. The resulting model may be described in terms of the first three rotor modes - teetering, symmetric bending and asymmetric bending - illustrated in Figure 1. In terms of these modes the displacement of a point on the blade is given by:

$$w(r, t) = \sum_{i=0}^2 q_i(t) \phi_i(r) \quad (1)$$

A fairly standard linear, aerodynamic perturbation method is used here which is illustrated in Figure 2. The most important influence that the blade motion  $w$ , and the turbulence perturbations  $u$  have on the aerodynamic loads is via a change in the inflow angle:

$$\Delta\beta = (u + \sum \ddot{q}_i \phi_i) / |r| \Omega \quad (2)$$

The resulting perturbation in distributed thrust is:

$$\Delta T = \frac{1}{2} \rho W^2 c a \Delta\beta \, dr \quad (3)$$

where  $r$  is the radial distance from the hub,  $\Omega$  the rotational speed of the rotor,  $W$  the magnitude of the apparent wind vector,  $c$  the chord,  $\rho$  the air density and  $a$  the lift curve slope.

### Equation of Motion

The equation of motion of the rotor neglecting structural damping may now be formulated as:

$$\begin{pmatrix} M_{21} & 0 & 0 \\ 0 & M_{22} & 0 \\ 0 & 0 & I \end{pmatrix} \ddot{q} + \begin{pmatrix} K_1 & 0 & 0 \\ 0 & K_2 & 0 \\ 0 & 0 & \Omega^2 \end{pmatrix} q = \begin{pmatrix} - \int \Delta T \phi_1 dr \\ - \int \Delta T \phi_2 dr \\ - \int \Delta T \phi_0 dr \end{pmatrix} \quad (4)$$

The subscript 0 denotes teetering and 1 and 2 denote symmetric and asymmetric bending respectively.  $I$  is the inertia and  $K_i$  are the generalised stiffnesses.

It was shown by Anderson, Garrad and Hassan (6) that some dimensionless parameters emerge naturally in the description of the rotor behaviour when excited by turbulence and these will be adopted here. Since vibrational modes have also been included here, other parameters are also required for a complete description. The analysis of an arbitrary blade has been undertaken, but since the object of this paper is to provide an illustration of this technique, rather than to perform a comprehensive analysis, the added complexity necessitated by the arbitrary description will be omitted and the analysis limited to a uniform blade. Under these conditions the behaviour may be described by the following dimensionless parameters:

- Lock number  $\gamma = 4\rho R^4 \omega^2 c/I$
- Tip speed ratio  $\lambda = r\Omega / U$
- Eddy size  $\eta = l/R$
- Mode shape  $\phi_i = \phi_i/R$
- Space  $x = r/R$
- Blade frequency  $p_i = \omega/\Omega$

plus numerous modal parameters such as:

$$D_i = \int x^2 dx \int \phi_i^2 |x| dx / \int \phi_i^2 dx$$

which will not be listed in detail.  $R$  is the radius of the rotor,  $l$  the length scale of longitudinal turbulence,  $U$  the mean wind speed and  $\omega_i$  the frequency of mode  $i$ .

### Formulation in the Frequency Domain

Equations (2) and (3) are substituted into equation (4) and the Fourier transform of the resulting equation is taken to yield a system of equations that describe the behaviour in the frequency domain. For an arbitrary blade these equations demonstrate that the symmetric bending mode is uncoupled from the other two, but that the teetering and asymmetric modes are coupled together. It is a fortunate characteristic of the uniform rotor that permits these modes to become uncoupled and results in three single degree of freedom oscillators. The last step is to transform the frequency domain equations into spectral form to obtain the result:

$$S_{jj}^F(p) = \left( \frac{\gamma}{8\lambda} \right)^2 \frac{c_j^2 S_{jj}^F(p)}{|A_{jj}|^2} \quad (5)$$

where

$$A_{jj} = (p_j^2 - p^2 + i D_j p)$$

$S_{jj}(p)$  is the power spectrum of  $q_j$ ;

$$S_{jj}^F(p) = \int_{-1}^1 \int_{-1}^1 |x_k| |x_l| \phi_j(x_k) \phi_j(x_l) S^U(x_k, x_l, p) dx_k dx_l$$

and  $S^U(x_k, x_l, p)$  is the spectrum of longitudinal turbulence suitably transformed to the rotating frame of reference.

## Results

Figures 3, 4 and 5 show the input spectra, the corresponding transfer functions and the resulting output spectra for the generalised co-ordinates for a rotor with the following characteristics:

$$\gamma = 3 \quad \lambda = 6, \quad \eta = 3, \quad p_1 = 3.5, \quad p_2 = 6.5$$

Reference to Figure 5 shows a large peak in teeter motion at  $p = 1$  (the rotational speed) indicating that the resonant nature of the teeter motion concentrates the available energy at its resonant frequency. This is due to both the rotor response and the redistribution of turbulence energy at the rotor speed and its harmonics. Above  $p = 1$  there is a rapid decay, although small peaks are clearly visible at  $p = 3, 5, 7$ , etc.

The rotor has been designed so that its resonant frequencies do not coincide with any harmonics of the rotor speed and hence the major peaks are at the resonant frequencies themselves. Again minor peaks are also visible at odd harmonics for the asymmetric mode and even harmonics for the symmetric mode. It should be noted that since the asymmetric and teetering modes only respond to differential loading they contain very little low frequency energy. This is because the scale of turbulence at low frequency is large with respect to the rotor and hence tends to engulf both blades. The symmetric mode on the other hand responds to symmetric loading and hence contains the large scale low frequency element.

## Interpretation of Spectra

Many authors have concluded their analyses at this point with the derivation of output spectra. These are of little use to the design engineer. Some effort was made in reference (6) to attempt an interpretation of the spectra by considering "zero crossing" analysis that allows frequency of exceedances of specific values (in this case teeter excursions) to be calculated. Similar estimates may be made for frequencies of peaks and their values. For buildings subject to wind loading these calculations are relatively straightforward since the time varying component of the load is purely stochastic. Unfortunately for a wind turbine the excitation is a mixture of periodic (deterministic) loads, arising from yaw misalignment, shaft tilt, tower shadow and shear, and stochastic turbulent loads. A mixture of these types precludes a straightforward analysis of zero crossing and although this problem is by no means peculiar to wind turbine technology it does require some further work to attempt to provide a useful working tool for design engineers.

Given these qualifications it is still possible to obtain some results about the importance of turbulent loads on wind turbine rotors. The statistical parameters that provide this insight are the moments of the spectra, or rather combinations of them. Their definition and interpretation is given in many standard texts and will not be reproduced here. The most important of these parameters are the variance,  $m_0$ ; the apparent up-crossing frequency,  $N^+$ ; and the irregularity factor  $\epsilon$ .

The simplest of these is the variance, which is shown in Figure 6 plotted for the three degrees of freedom in the present model for a variety of rotor characteristics for unit turbulence intensity. Various trends emerge from the Figure. The change of teeter variance with Lock Number is relatively small,

whereas the corresponding change in the bending modes is quite large - sometimes up to 3 orders of magnitude as  $\gamma$  changes from 1 to 10. The dependence on the other parameters, tip speed ratio and turbulence scale, is very mild - the four graphs in Figure 6 all have very similar shapes. The variance reduces with increasing  $\lambda$  for both bending modes; the variation in the symmetric bending mode with length scale is scarcely discernible, but the asymmetric variance clearly decreases with increasing length scale, as the loading becomes more uniform across the disc.

Figure 7 shows a similar series of graphs for the up-crossing frequency. This parameter gives a guide to the dominant frequency of the spectrum. Reference to Figure 5 shows clear peaks at distinct frequencies which can be seen plotted in the graphs of Figure 7. The coincidence of the apparent up-crossing frequency and the resonant frequency indicates that the response is narrow band - the teetering response is an excellent example of this. The frequencies plotted for both bending modes, but particularly the symmetric mode, display a considerable variation with Lock number, tip speed ratio and turbulence length scale indicating that the response to turbulence is quite sensitive to rotor and site characteristics.

The final parameter of interest is the irregularity factor  $\epsilon$  from which the likely distribution of peaks may be deduced. The value of  $\epsilon$  ranges from 0 to 1, 0 indicating that the peaks from a Rayleigh and 1 indicating a Gaussian distribution. For the cases considered here  $\epsilon$  varies from 0.08 to 0.3 for the teeter and asymmetric bending and from 0.6 to 0.8 for the symmetric bending, demonstrating the effect of the low frequency content on the symmetric bending that is not present for the other two modes.

### Numerical Example

To put these calculations in context it is illustrative to assess the importance of the turbulence induced loads with respect to the deterministic loads. Consider a machine characterised by the following parameters:

$$n = 3, \quad \gamma = 4, \quad \lambda = 6, \quad I_u = 12\%, \quad \Omega = 34 \text{ rpm}$$

Taking typical mass values, an rms value of the stochastic flatwise root bending moment of 0.17 MNm is obtained compared with an rms value of 0.14 MNm for the deterministic part due to a typical shear profile, tower shadow and yaw angle. The precise value of these should be treated with some caution since the approximations in modelling the blade may have a considerable effect on their size. The figures do, however, demonstrate that turbulent and deterministic loads may be of comparable magnitude.

### Conclusions

This paper has outlined a model that is capable of predicting the dynamic loads induced in a teetered rotor by turbulence. The analysis is approximate but it has demonstrated that these loads are of importance in the flatwise direction. However, the major fatigue loads are due to gravity and the gravitational edgewise loads are usually the dominant factor in blade fatigue design.

Further work is required to assess the influence of turbulence on the support structure and consideration is required to develop an adequate means of using this type of analysis for basic blade design.



### Acknowledgements

The authors wish to thank the UK Department of Energy and Taylor Woodrow Construction Limited for their support and permission to publish this work.

### References

- (1) Wyatt, T.A. "The Dynamic Behaviour of Structures Subject to Gust Action"  
Proc. CIRIA Conference "Wind Engineering in the Eighties" November 1980
- (2) Rosenbrock, H.H. "Vibration and Stability Problems in Large Wind Turbines Having Hinged Blades"  
ERA Report C/T 113 (1955)  
ERA, Cleeve Road, Leatherhead, Surrey.
- (3) Kristensen, L.  
and  
Frandsen, S. "Model for Power Spectra of the Blade of a Wind Turbine Measured from the Moving Frame of Reference"  
Journal of Wind Engineering and Industrial Aerodynamics, 10, No.2, (1982)
- (4) Anderson, M.B. "The Interaction of Turbulence with a Horizontal Axis Wind Turbine"  
Proc. 4th BWEA Wind Energy Conference, Cranfield, UK (1982) pp 104-118.
- (5) Connell, J.R. "The Spectrum of Wind Speed Fluctuations Encountered by a Rotating Blade of a Wind Energy Conversion System: Observation and Theory"  
Battelle Pacific Northwest Laboratory Report PNL 4983 (1981)
- (6) Anderson, M.B.,  
Garrad, A.D.  
and  
Hassan, U. "Teeter Excursions of a 2-Bladed Horizontal Axis Wind Turbine Rotor in a Turbulent Velocity Field"  
To be published
- (7) Garrad, A. "An Approximate Method for the Dynamic Analysis of a 2-Bladed Horizontal Axis Wind Turbine Systems"  
Proc. 4th International Symposium on Wind Energy Systems, Stockholm, September 1982.

Fig 2

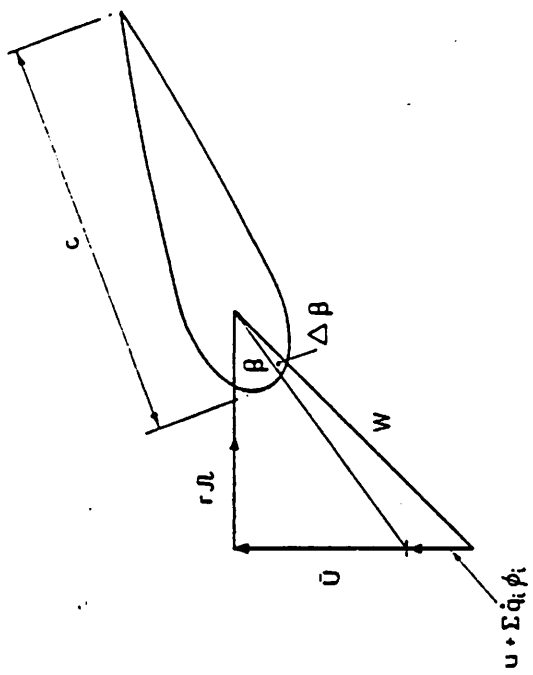

$$dT = \frac{1}{2} \rho W^2 c \alpha \Delta\beta \, dr$$

$$\Delta\beta = \frac{u + \sum q_i \phi_i}{i r \Omega}$$

AERODYNAMIC MODEL.

Fig 1.

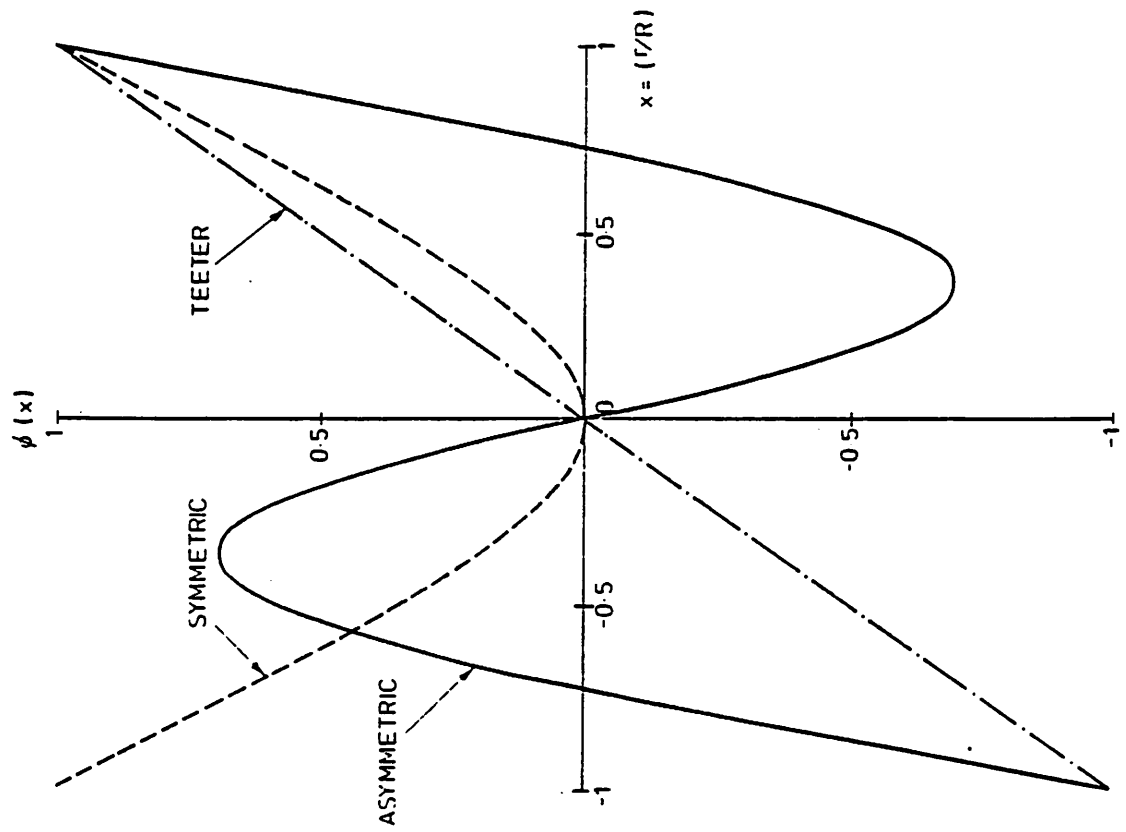

MODE SHAPES FOR UNIFORM BEAM.

Fig 3

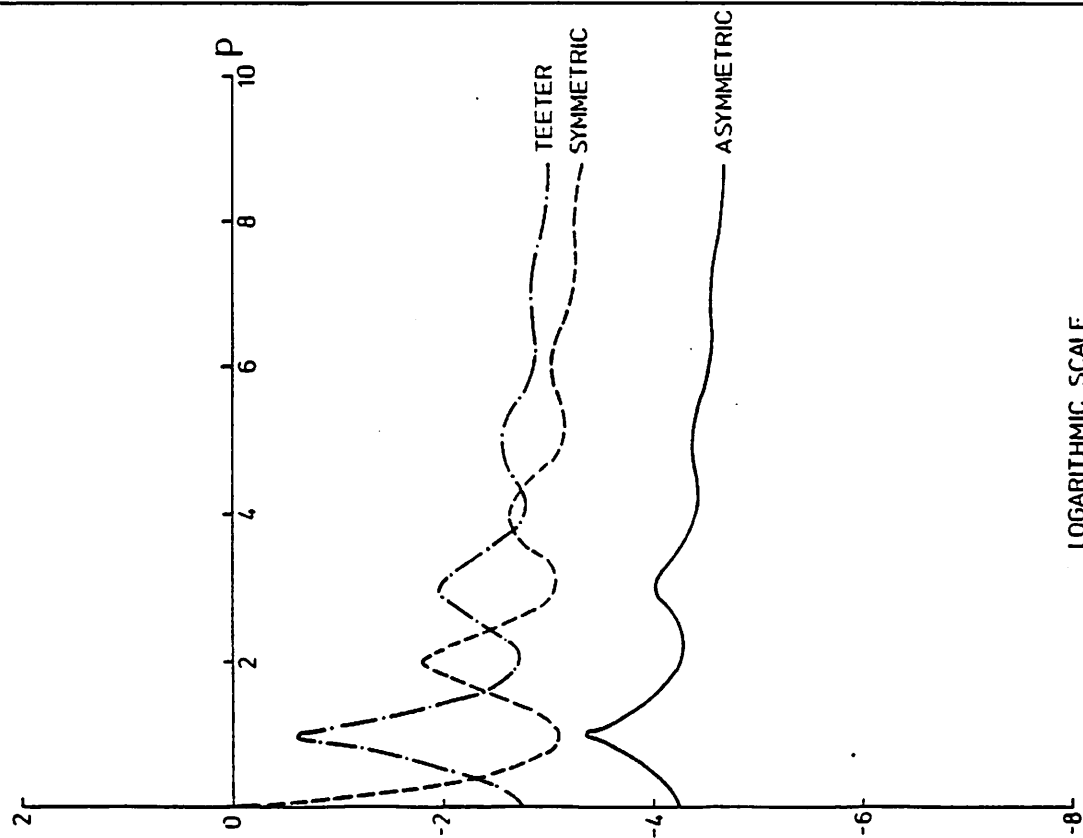

LOGARITHMIC SCALE

INPUT SPECTRA :  $\gamma=3, \lambda=6, \eta=3$

Fig 4.

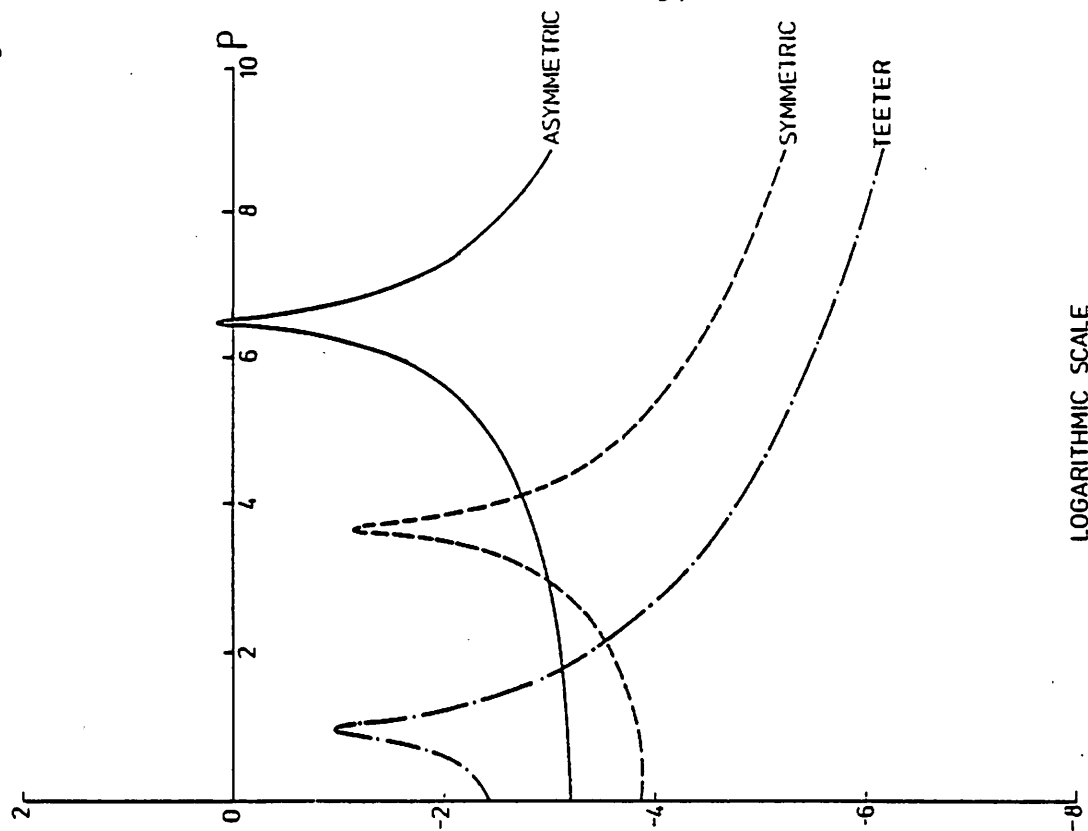

LOGARITHMIC SCALE

TRANSFER FUNCTIONS :  $\gamma=3, \lambda=6, \eta=3, \rho=3.5, \rho_2=6.5$

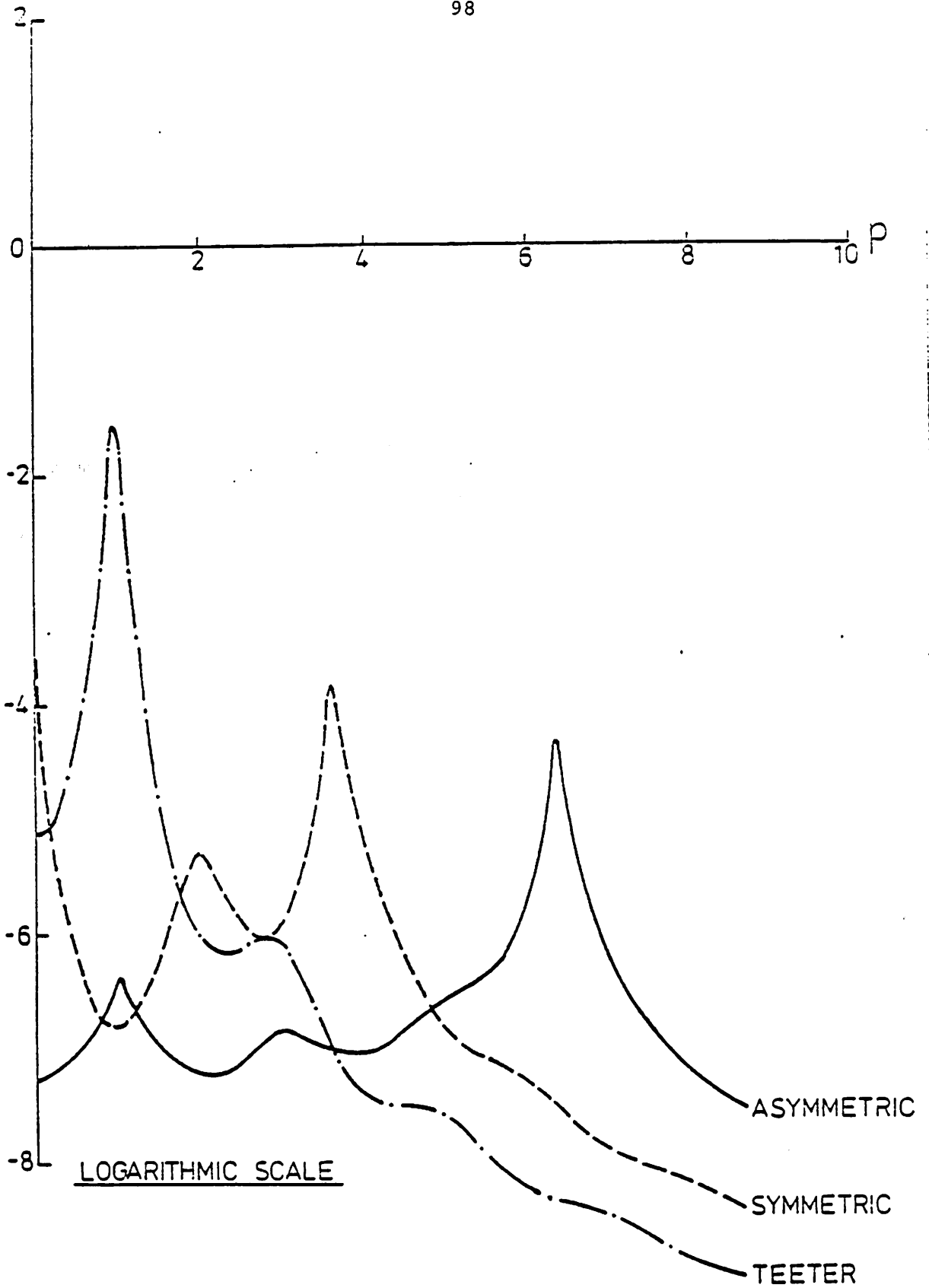

OUTPUT SPECTRA:  $\gamma=3, \lambda=6, \eta=3.$

Fig. 6

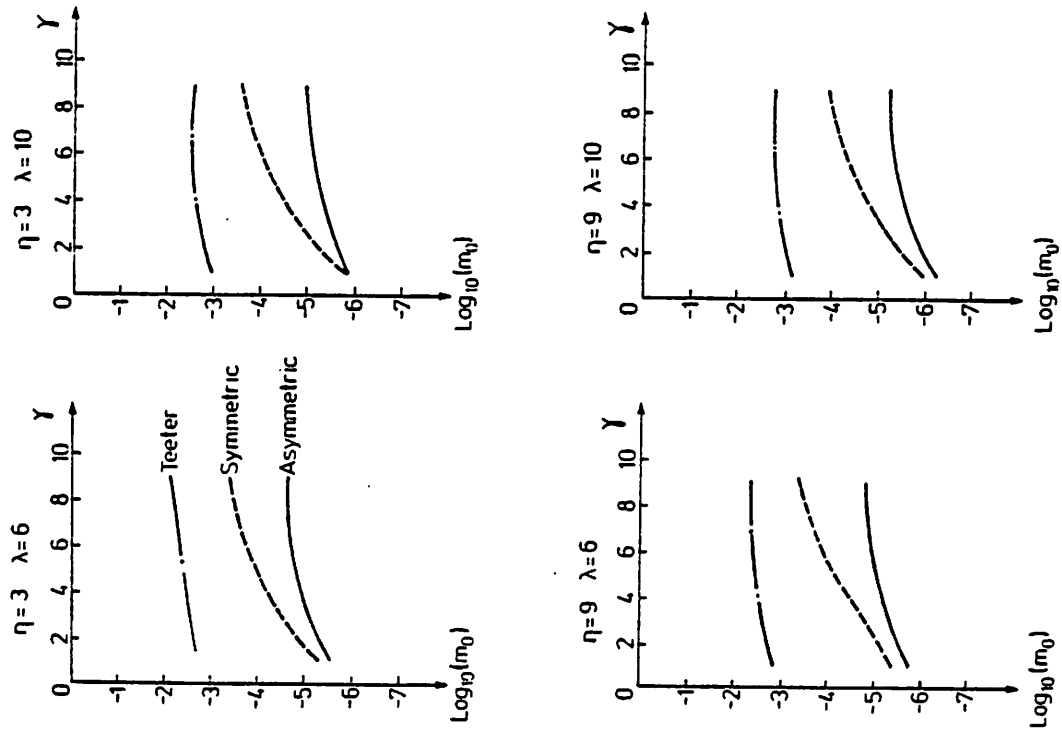

LOG (VARIANCE) versus LOCK NUMBER( $\delta$ )

Fig. 7

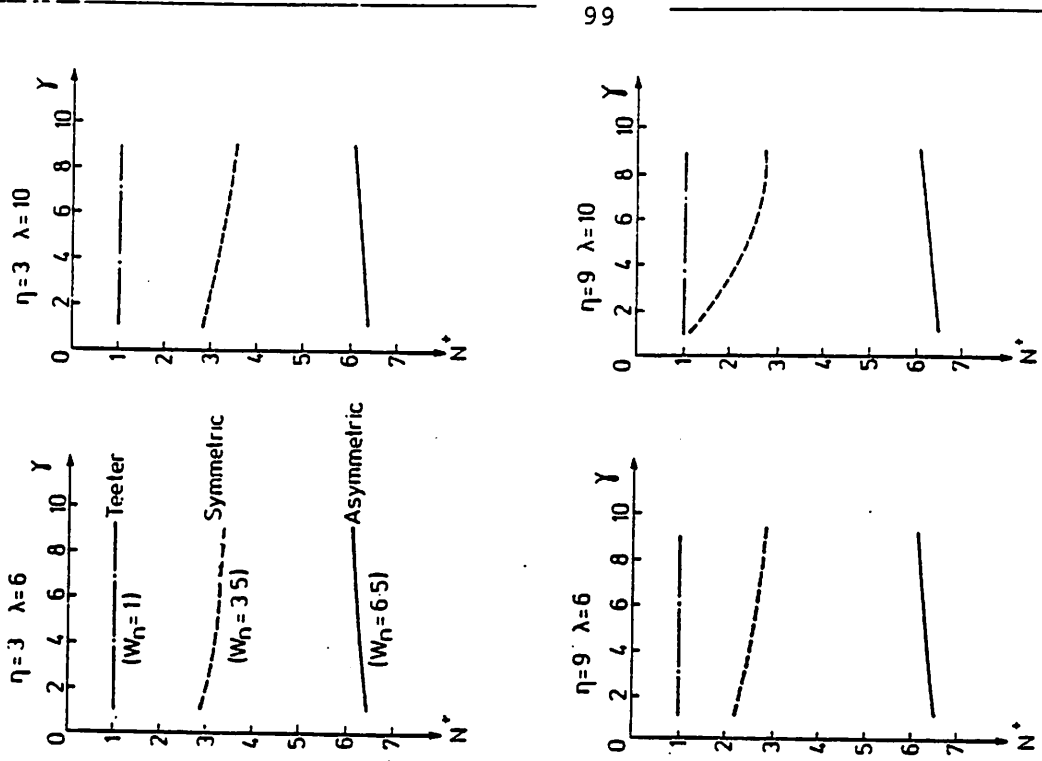

APPARENT UP-CROSSING FREQUENCY versus LOCK NUMBER

## PART II

WIND LOADS TO BE CONSIDERED IN  
THE DESIGN OF A WTG INCLUDE

- EXTREME LOADS
  - operational
  - non-operational
  
- FATIGUE LOADS
  - wind gradient
  - yaw
  - tower shadow
  - turbulence

To determine extreme and fatigue loads due to turbulence, the statistics of peak loading are required.

The probability density function for peaks of a random function with a normally distributed parent population has been derived by Rice:

$$p(\eta) = \underbrace{\frac{\varepsilon}{\sqrt{2\pi}} e^{-\eta^2/2\varepsilon^2}}_{\text{"Gaussian" term}} + \underbrace{\frac{\eta}{2} (1-\varepsilon^2)^{1/2} e^{-\eta^2/2} \left[ 1 + \operatorname{erf}\left(\eta \sqrt{\frac{1-\varepsilon^2}{2\varepsilon^2}}\right) \right]}_{\text{"Rayleigh" term}}$$

$$\varepsilon = \left( 1 - \frac{m_2}{m_0 m_4} \right)^{1/2} = \left( 1 - \frac{N_0^2}{N_1^2} \right)^{1/2} \quad \begin{array}{l} = 0 : \text{Rayleigh} \\ = 1 : \text{Gaussian} \end{array}$$

$$\text{where } m_r = \int_0^{\infty} n^r S(n) dn$$

$$N_0 = \sqrt{\frac{m_2}{m_0}} \quad - \text{frequency of zero up-crossings}$$

$$N_1 = \sqrt{\frac{m_4}{m_2}} \quad - \text{frequency of peaks}$$

PROBABILITY DISTRIBUTION OF PEAKS FOR DIFFERENT TYPES OF FLUCTUATIONS.

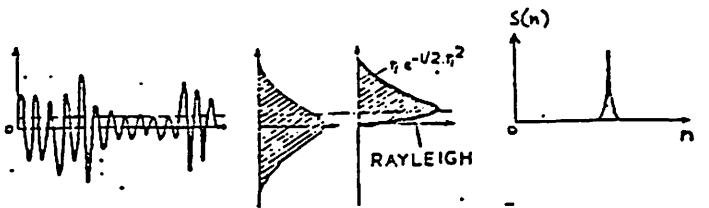
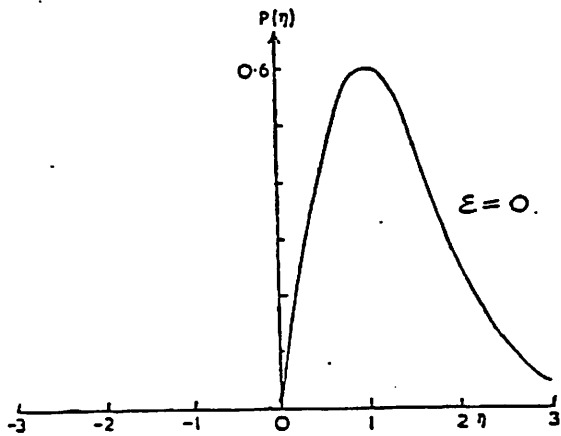
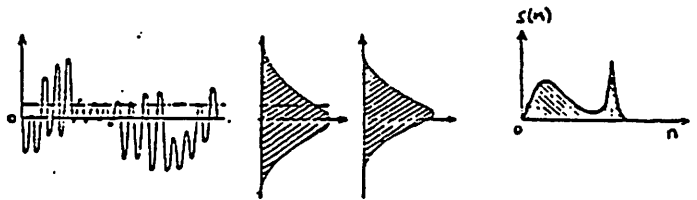
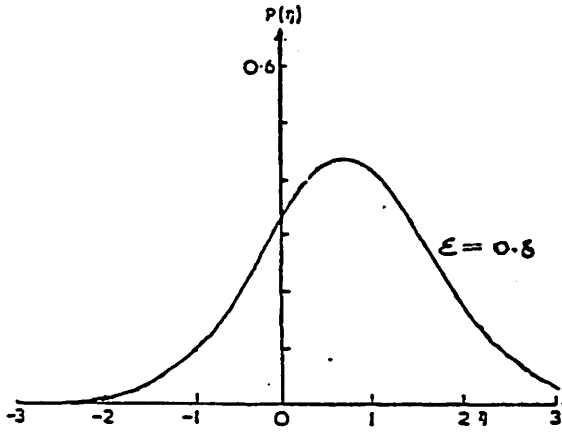
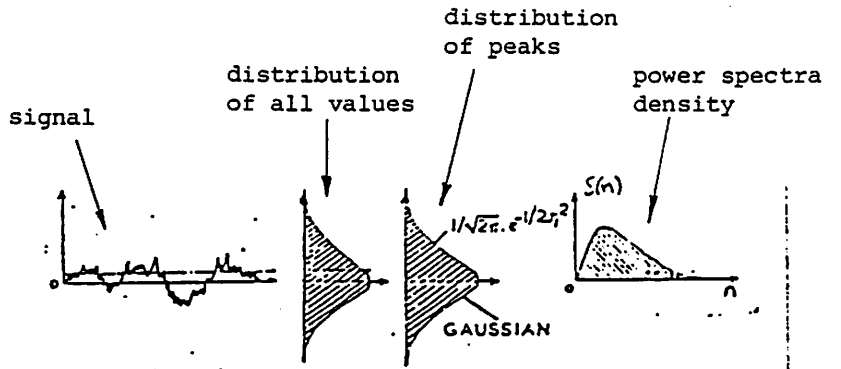
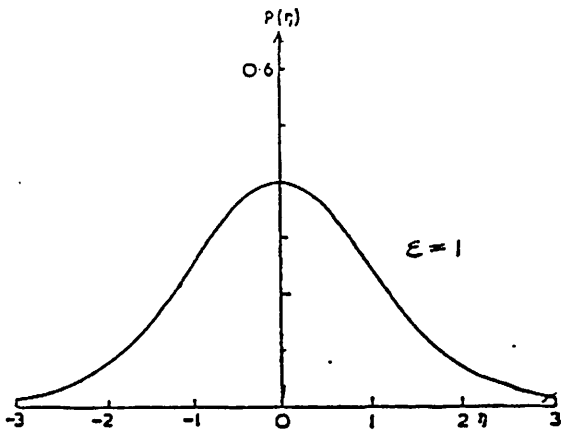



For ultimate load analysis the prime concern is not the distribution of all the maxima which occur within a certain period, but only with the largest of these.

Relationship of distribution of largest instantaneous values of random function to the distribution of all values and all peaks.

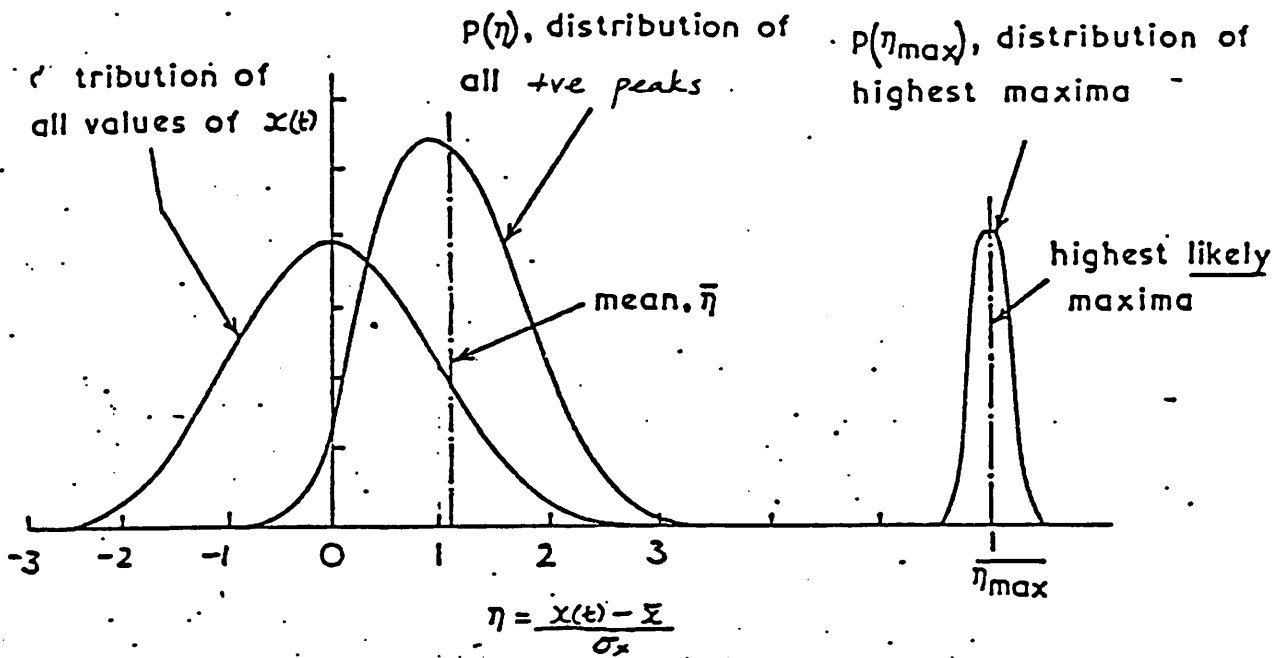

## HIGHEST LIKELY MAXIMA

- FOR A GAUSSIAN DISTRIBUTION OF PEAKS ( $\epsilon \rightarrow 1$ )

$$\bar{\eta}_{\max} = \sqrt{2 \ln N_0 T / \sqrt{2\pi}}$$

- FOR A RAYLEIGH DISTRIBUTION OF PEAKS ( $\epsilon \rightarrow 0$ )

$$\bar{\eta}_{\max} = \sqrt{2 \ln N_0 T} + \frac{0.577}{\sqrt{2 \ln N_0 T}}$$

## APPLICATION TO GUST LOADING

## GUST WIND SPEEDS

$$\begin{aligned}
 U_{\text{gust}} &= \bar{U} + \bar{\eta}_{\text{MAX}} \cdot \sigma_u \\
 &= \bar{U} \left( 1 + \eta_{\text{MAX}} \cdot I_u \right) \quad (I_u - \text{intensity of turbulence})
 \end{aligned}$$

$$\text{Gust Factor} = 1 + \bar{\eta}_{\text{MAX}} \cdot I_u$$

## LOADS (such as bending moments)

$$BM_{\text{MAX}} = BM_{\text{MEAN}} + \bar{\eta}_{\text{MAX}} \cdot \sigma_{BM}$$

$$\text{Peak Factor} = 1 + \frac{\bar{\eta}_{\text{MAX}} \cdot \sigma_{BM}}{BM_{\text{MEAN}}}$$

## FATIGUE LOAD ANALYSIS

For Fatigue Load Analysis the cyclic deformation of the material is important. To predict fatigue life the discrete load reversals in the load history must be known. The distribution of peaks and troughs need to be considered.

In a load history where there is only one peak in each main half cycle as in the following example:

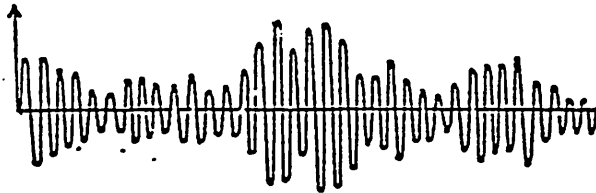

The distribution of peaks and troughs is given by a Rayleigh Distribution:

$$p(\eta) = \eta \cdot e^{-\eta^2/2}$$

Where the number of peaks is

$$N = N_0 T \quad (T - \text{averaging period, usually 1 hour})$$

If the load spectrum is broad band as in the following example:

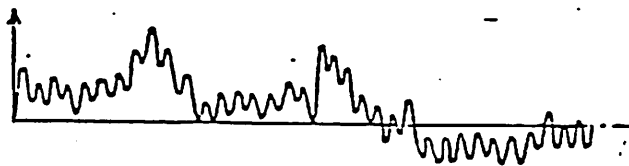

The distribution of maxima approaches a Gaussian Distribution. There are a number of maxima in each half cycle. Since fatigue is a consequence of strain reversals, the most appropriate methods of cycle counting are those which identify and characterise ranges.

A probability distribution of peak loads which significantly deviates from a Rayleigh Distribution cannot be used to characterise ranges. It is recommended that for such cases a time history of loads be synthesised, from the load power spectrum, and analysed using a rainflow cycle counting method.

Björn Montgomerie, FFA

"Some Aspects of the Structural Loading Criteria Applied to the Swedish Megawatt Wind Turbines".

Abstract: The experience from the Swedish Load Specification, Load Case 11 will be presented. This load case requires the structure to remain standing should a blade break off near the hub during operation. Calculations and consequences will be covered. The same topic was treated at the Stockholm, Sheraton, Fourth International Symposium on Wind Energy Systems in September 82. Further, if the ongoing evaluation of the testing of the WTS-3 machine in Maglarp is completed, certain aspects of load prediction versus measured loads may be presented.

---

→ Summary of earlier work published at the 4th International Symposium on Wind Energy Systems in Stockholm September 21-24, 1982, as

Paper G1. Two-bladed horizontal axis wind turbine blade failure dynamics applied to tower, nacelle and remaining blade.

Paper N5. Horizontal axis wind turbine blade failure, blade fragment six degrees of freedom trajectory, site risk level prediction.

Expert Meeting : "Structural Design Criteria for LS WECS"  
Greenford, Middlesex, 7th and 8th March, 1983

LOAD CASES FOR THE STRUCTURAL DESIGN OF GROWLAN AND  
SOME SIGNIFICANT RESULTS OF THE LOAD CALCULATIONS

by

G Huß & E Hau

## LOAD ASSUMPTIONS FOR WECS

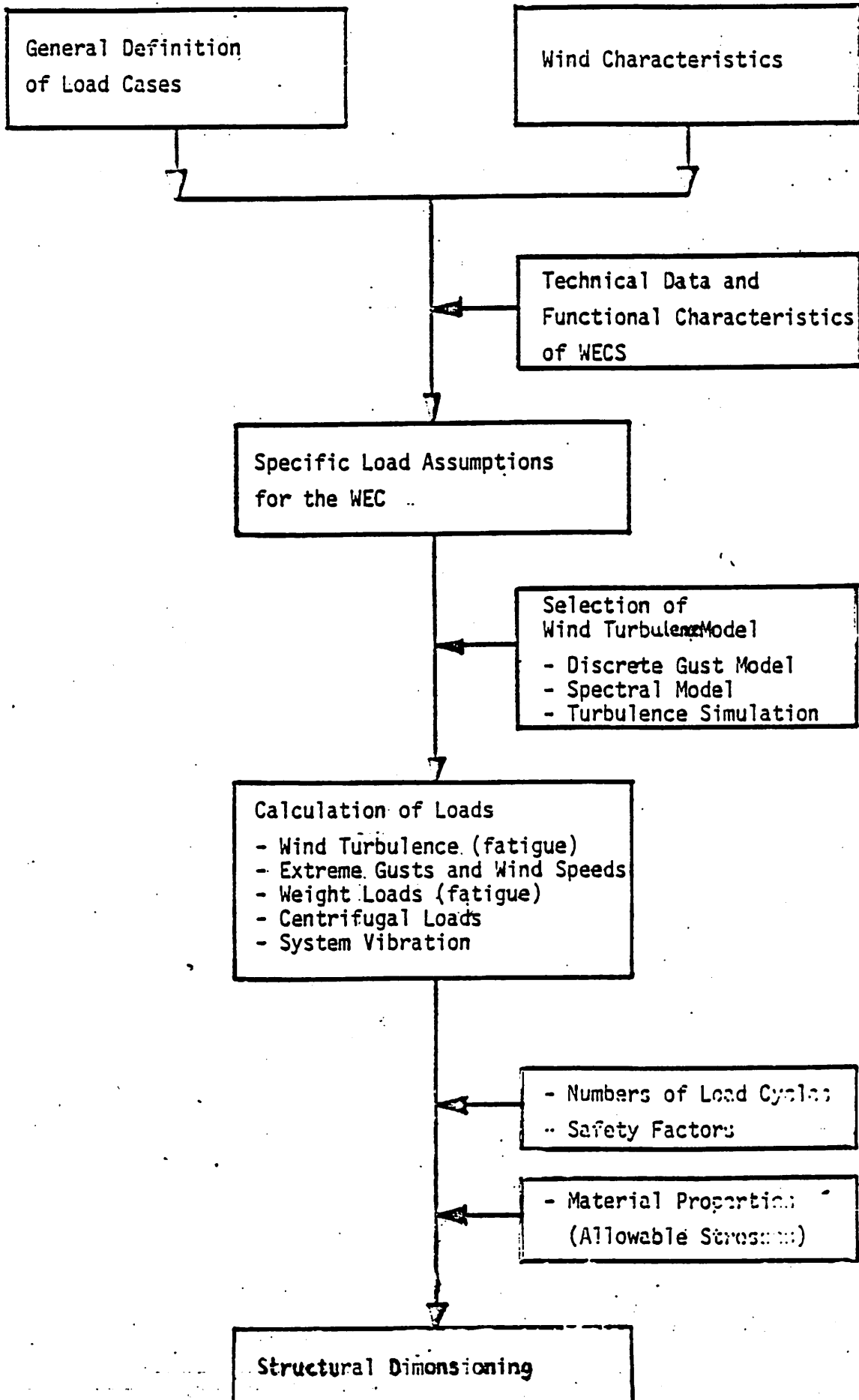



# GENERAL DEFINITION OF LOAD CASES FOR GROWIAN

## ● Normal Operation

- Steady wind speeds from 6 up to 24 m/s
- Turbulence (discrete gusts)

## ● Start-up and Shut-down Sequences

- Normal sequence of start-up and stop
- Emergency stop

## ● Loads on Parked WECS

- Wind speeds up to 60 m/s

## ● Loads due to Faults

- Mechanical or electrical malfunctions
- Loss of one blade (not considered for GROWIAN)

# SPECIFIC LOAD ASSUMPTIONS FOR GROWIAN

	Definition	Windspeed m/s	Rotational speed min <sup>-1</sup>	Pitch angle °	Safety factor	Load cycles
Normal Operation	$V_{ci}$	5.5	16.65	-1	1.2 (fatigue)	$3.9 \cdot 10^7$
	$V_1$	9.9	16.65	-1	1.2	$3.9 \cdot 10^7$
	$V_N$	12	18.5	-1	1.2	$4.3 \cdot 10^7$
	$V_2$	18	18.5	-12	1.2	$2.3 \cdot 10^7$
	$V_{co}$	24	18.5	-19	1.2	$4.0 \cdot 10^6$
Extreme Turbulence	Up-Gust at $V_N$	12 → 24 → 12	18.5	-1	1.5 (break)	50 ( $10^4$ )
	Down-Gust at $V_{co}$	24 → 14 → 24	21.3	-16.9	1.5	50 ( $10^4$ )
	Up-Gust at $V_{co}$	24 → 40 → 24	21.3/15.7	-16.9/-21	1.5	50
	Down-Gust at $1.25 V_{co}$	30 → 18 → 30	21.3	-22.3	1.5	50
Start-Stop Sequences	Start-up	$V_{ci}$ and $V_{co}$	$0 \rightarrow n_N$	controlled	1.2	$1.8 \cdot 10^4$
	Shut-down	$V_{ci}$ and $V_{co}$	$n_N \rightarrow 0$	controlled	1.2	$1.8 \cdot 10^4$
	Emergency stop	$V_N$ and $V_{co}$	$1.2 n_N \rightarrow 0$	fast/slow rate 14 / 1 °/s	1.5	50
Parked IECS	Maintenance	45.6 (DIN 1055)	0	-90 vertical rotor	1.5	-
	Survival	60	0	-90 horizontal rotor	1.5	-
Faults Environment effects	Ice loads	45.6/12	$0/n_N$			
	Bird collision	$15 V_N + 15$ m/s	$n_N$			

## WIND CHARACTERISTICS

### 1. Steady winds between cut in and cut out

	Wind speed class	Time fraction of 1 year	Load cycles during service life
$V_{ci}$	5 - 8 m/s	22 %	$3.9 \cdot 10^7$
$V_1$	8 - 10.7 m/s	22 %	$3.9 \cdot 10^7$
$V_N$	10.7 - 15 m/s	22 %	$4.3 \cdot 10^7$
$V_2$	15 - 21 m/s	12 %	$2.3 \cdot 10^7$
$V_{co}$	21 - 25 m/s	2 %	$4.0 \cdot 10^6$

\*) Operating at 90 % of rated rotational speed

### 2. Superimposed periodic loading

- Tower shadow
- Wind shear
- Cross winds

### 3. Superimposed continuous turbulence

Periodic sequence of discrete gusts with length scale fraction  $\lambda/H \approx 1$  and load factor  $\bar{f}_g < 1.3$ .

# WIND CHARACTERISTICS

## 4. Superimposed extreme turbulence

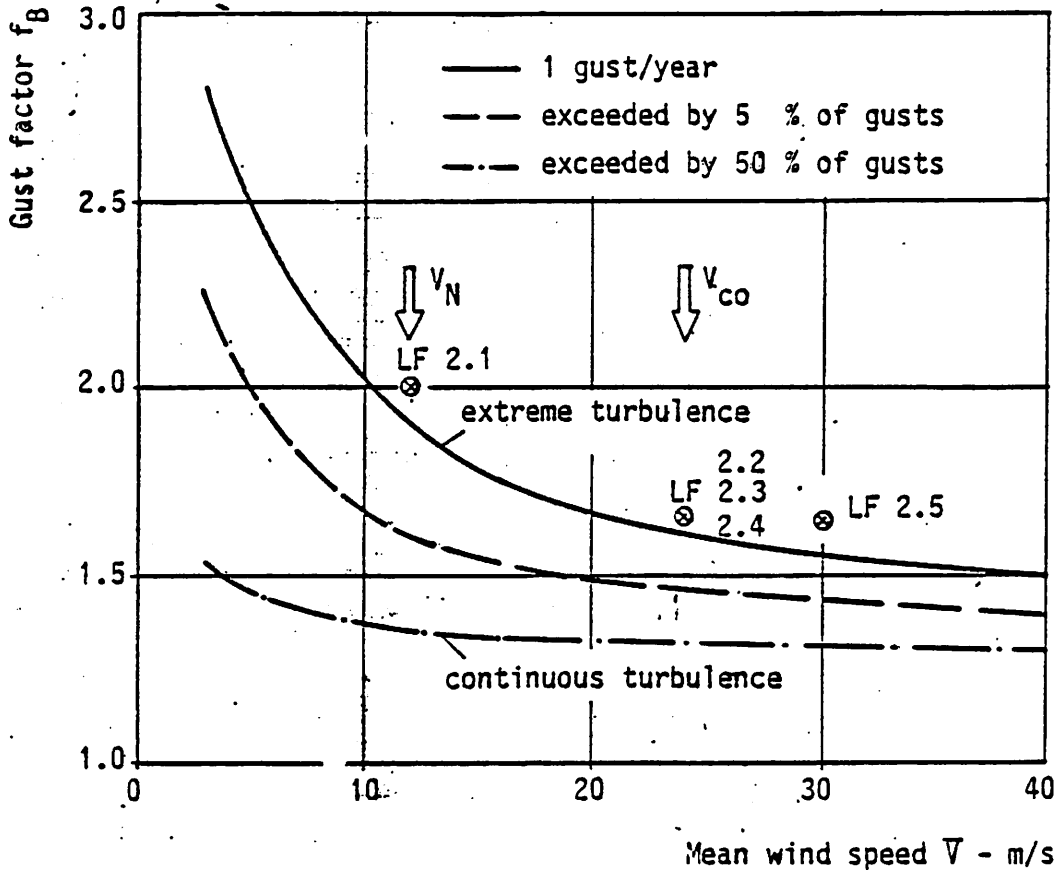

Gust factor versus mean wind speed (acc. to Meteor. Inst. of TU Hannover)

Gust factor  $f_B$ :

$$f_B = \frac{V_B + \bar{V}}{\bar{V}}$$

$V_B$  = Gust amplitude

$\bar{V}$  = Mean wind speed (10 min average)

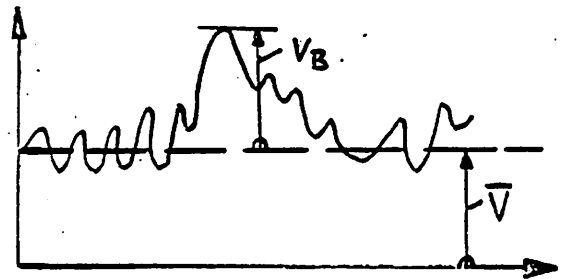

DISCRETE GUST MODEL

- Up-Gusts

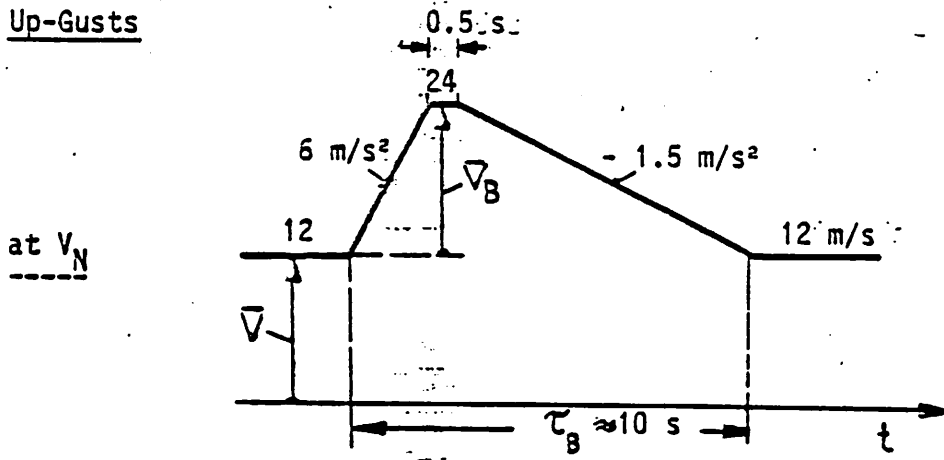

$f_B = 2$

$N = 50 (10^4)$

at  $V_{co}$

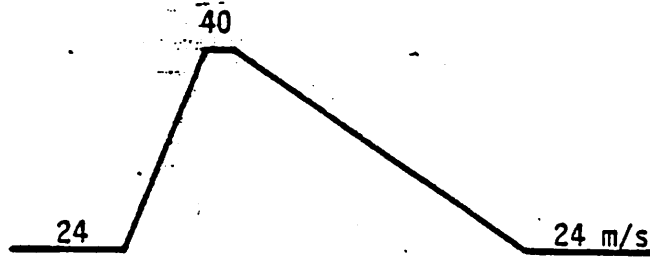

$f_B = 1.7$

$N = 50$

- Down-Gusts

at  $V_{co}$

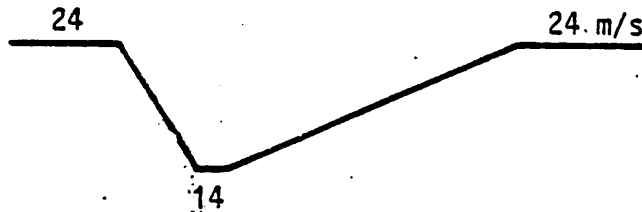

$f_B = 0.6$

$N = 50 (10^4)$

at  $1.25 V_{co}$



$f_B = 0.6$

$N = 50$

Basic assumption: Blade pitch angle remains constant at its original position

RESULTS OF LOAD CALCULATIONS

Example 1:

Stresses of the blade spar in normal operation

Service life: 20 years

Steel St-52:  $\sigma_B = 520 \text{ N/mm}^2$ ,  $\sigma_{0.2} = 360 \text{ N/mm}^2$

$\sigma_{allow}$ . depends upon welding quality and  $\sigma_{min}/\sigma_{max}$ -fraction

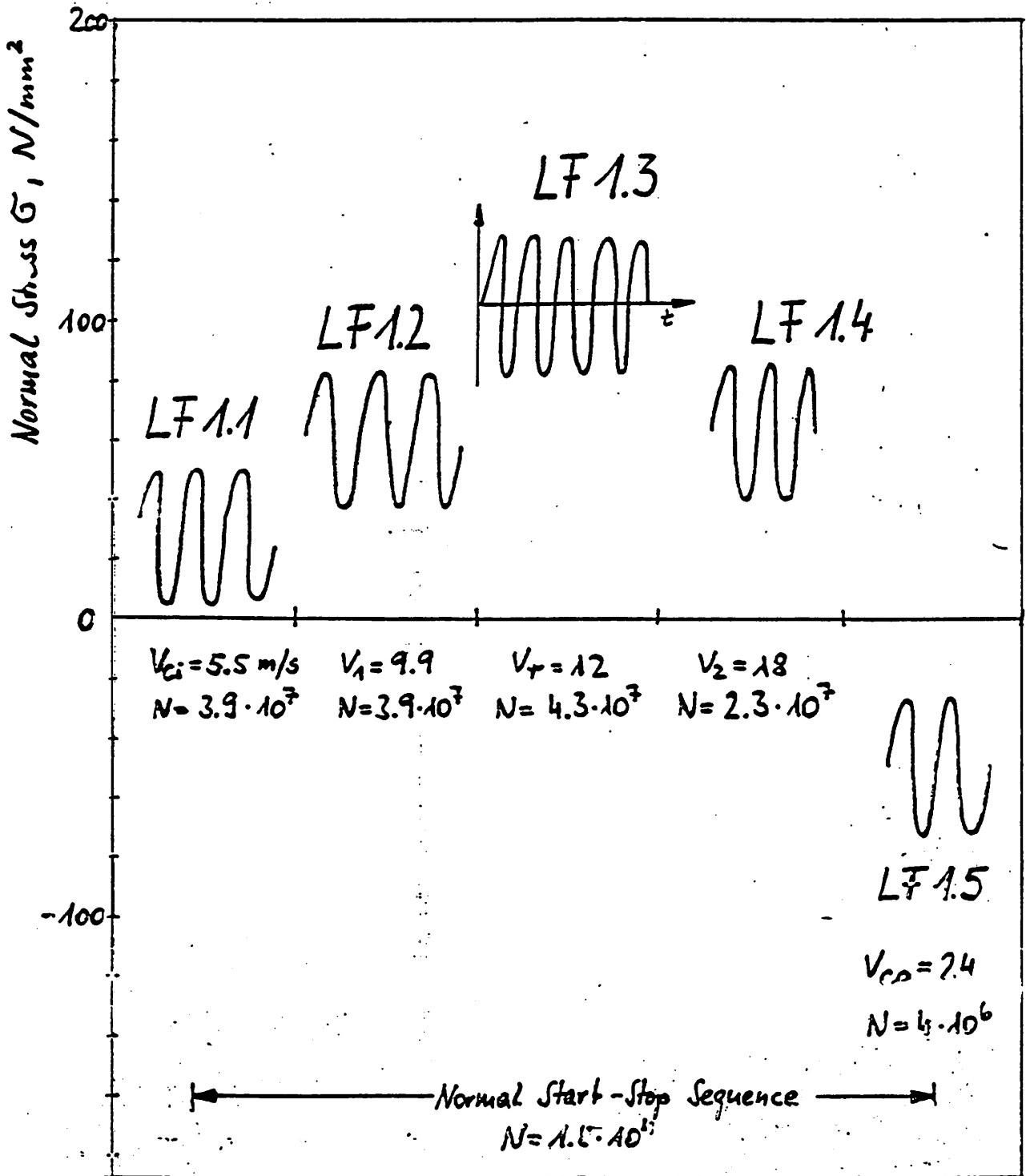

# RESULTS OF LOAD CALCULATIONS

Example 2: Emergency shut down by the hydraulic blade pitch system

- generator break down
- failure of the electrical blade pitch system

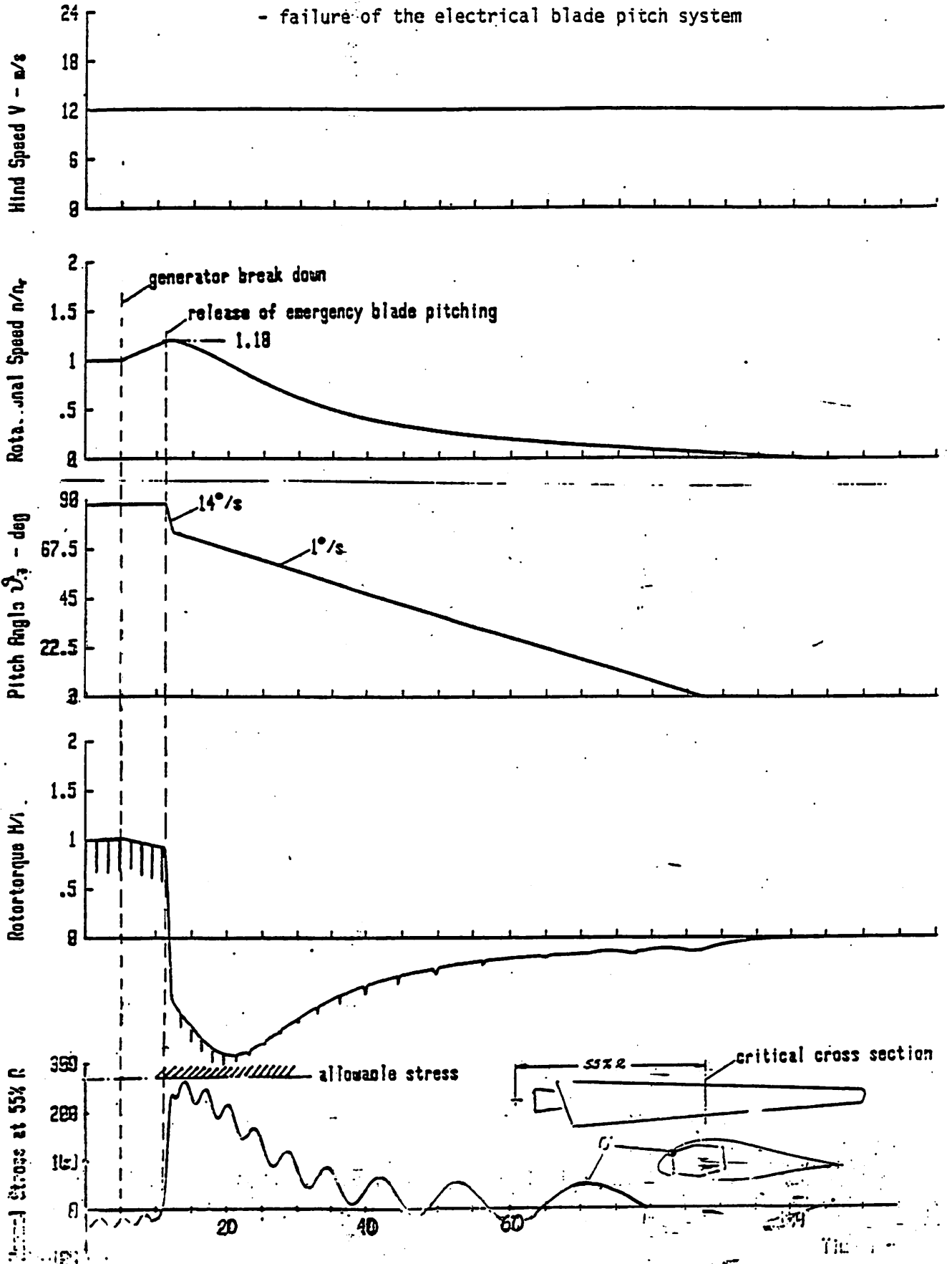

LOAD CASES FOR MEDIUM SIZED WIND POWER PLANTS

B Dahlroth

VAST

The Swedish Power Association Development Section

VAST has recently revised the technical requirements that were set up for the large Swedish prototypes. The revision has been made with the aim to ask for tenders for a 50 m hubheight horizontal axis wind power plant. The bidding will, at least in a first stage, be limited to three suppliers situated in Scandinavia and who have cooperated with VAST in parts of the VASTVIND project. A condition for the project is that the financing can be arranged.

"Load cases" can not be considered apart from other technical requirements. They are for instance intimately connected with stated wind conditions. For this reason the complete section "special technical requirements" of the rewized tender documents is submitted. Discussions in the meeting should, however, center around the load cases and the selection of extreme wind speeds.

The selection of extreme wind speeds have been based on calculated distributions of extremes for the typical site defined in the specification. The calculations have been made by Ann-Sofie Smedman at Uppsala university. The distributions for various sectors are depicted in figure 1, 2 and 3. The vertical axis is the probability that a wind speed will be exceeded during a certain time period (1, 10 and 50 years). Wind speeds are averaged over 10 minutes, 1 minute and 3 seconds.

To define load cases is an important part of the setting of an acceptable risk of break down. Risk evaluation is difficult. Due to lack of funds, experience and useful statistical information, it must to a high degree be based on feeling and on qualified judgement. An overall permissible risk level is also difficult to define. If many load cases are defined and only a few prove to be dimensioning this could be due to either that most of the load cases are not relevant or that the design is not optimal in all parts.

During the work on these documents it has gradually become obvious that it is not possible to define a small number of critical load cases that are dimensioning for any kind and size of wind power plant. Even if a detailed design of plant is specified the load at a defined extreme wind speed could vary significantly depending on method of parking and eventual existing faults in the control system.

An element that is also important to consider with the load cases is that the commercial section of the tender specification defines a special extended warranty period for certain faults like fatigue, brittle fracture and excessive wear to put the guarantee requirements in reasonable level with what is normal for conventional machinery for power production.



SECTOR I WATER

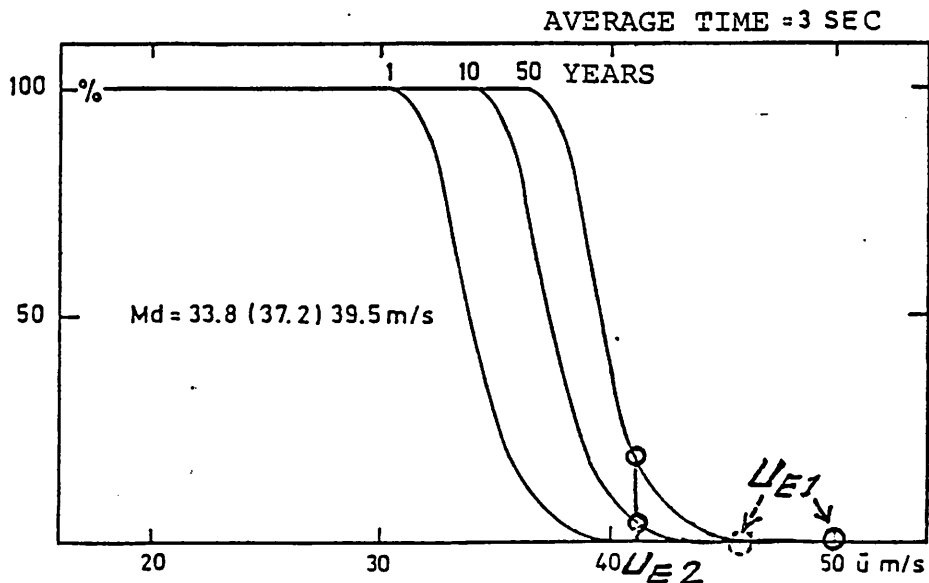
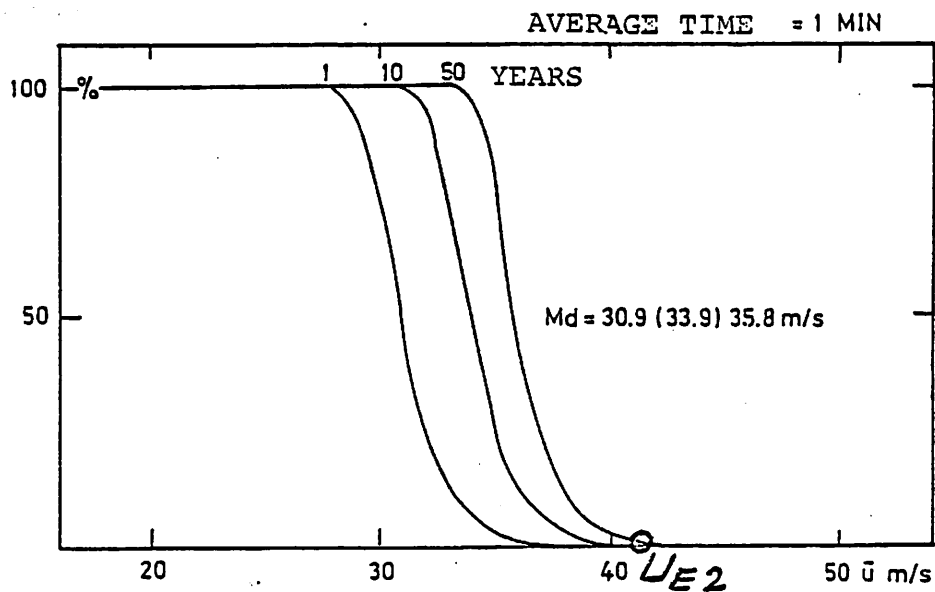
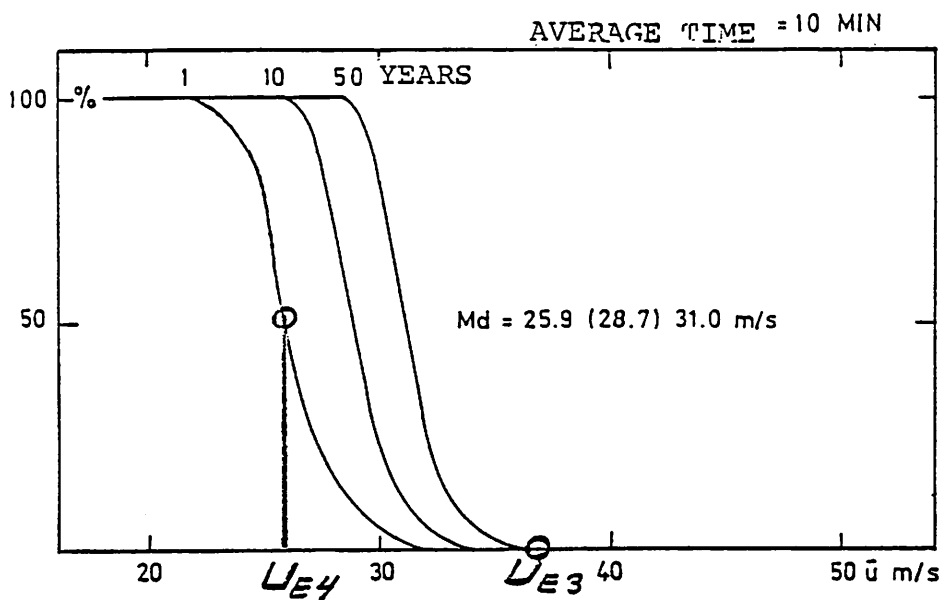

FIG I

SECTOR II FIELDS

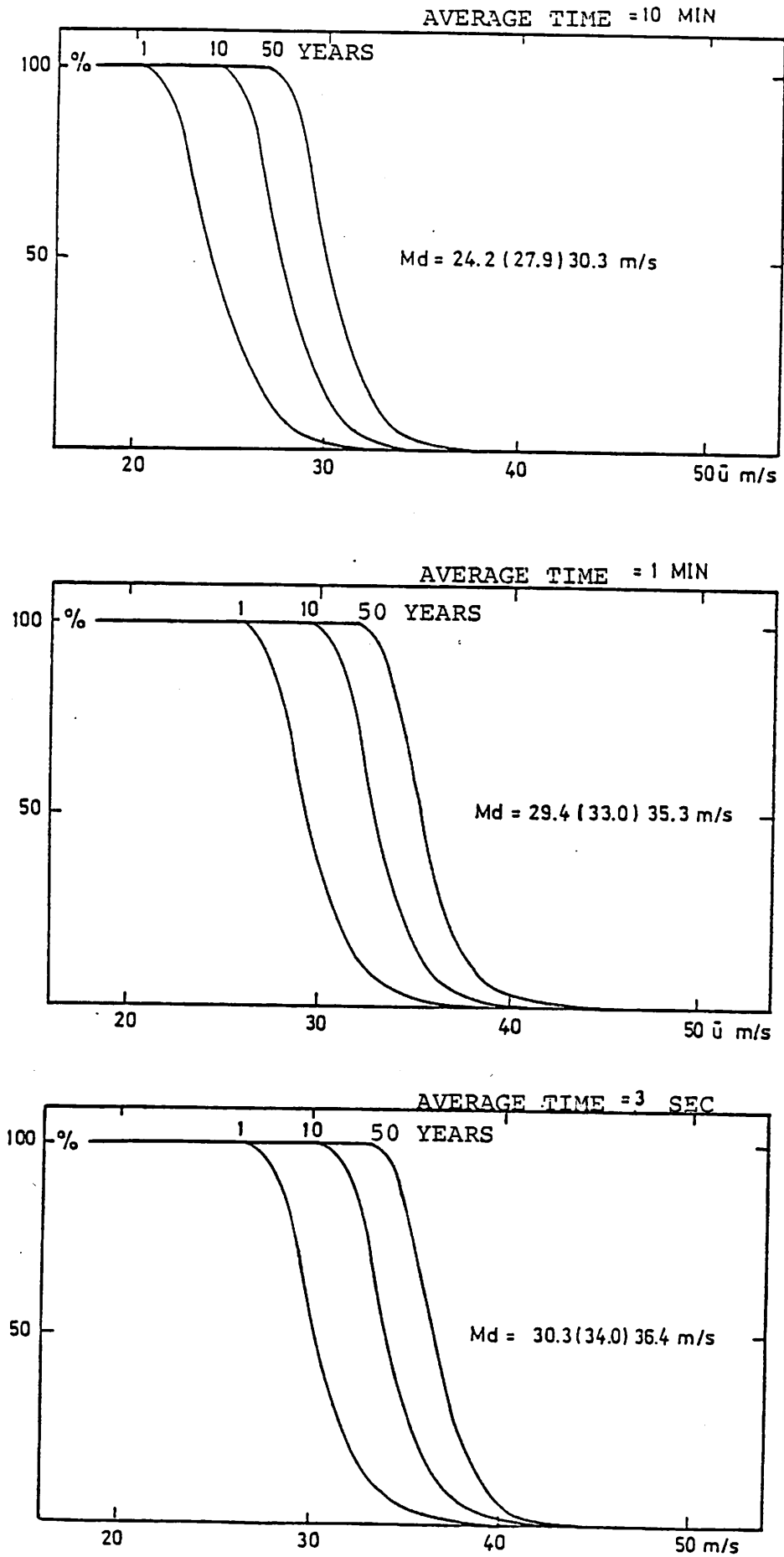

FIG II

## SECTOR III FORREST

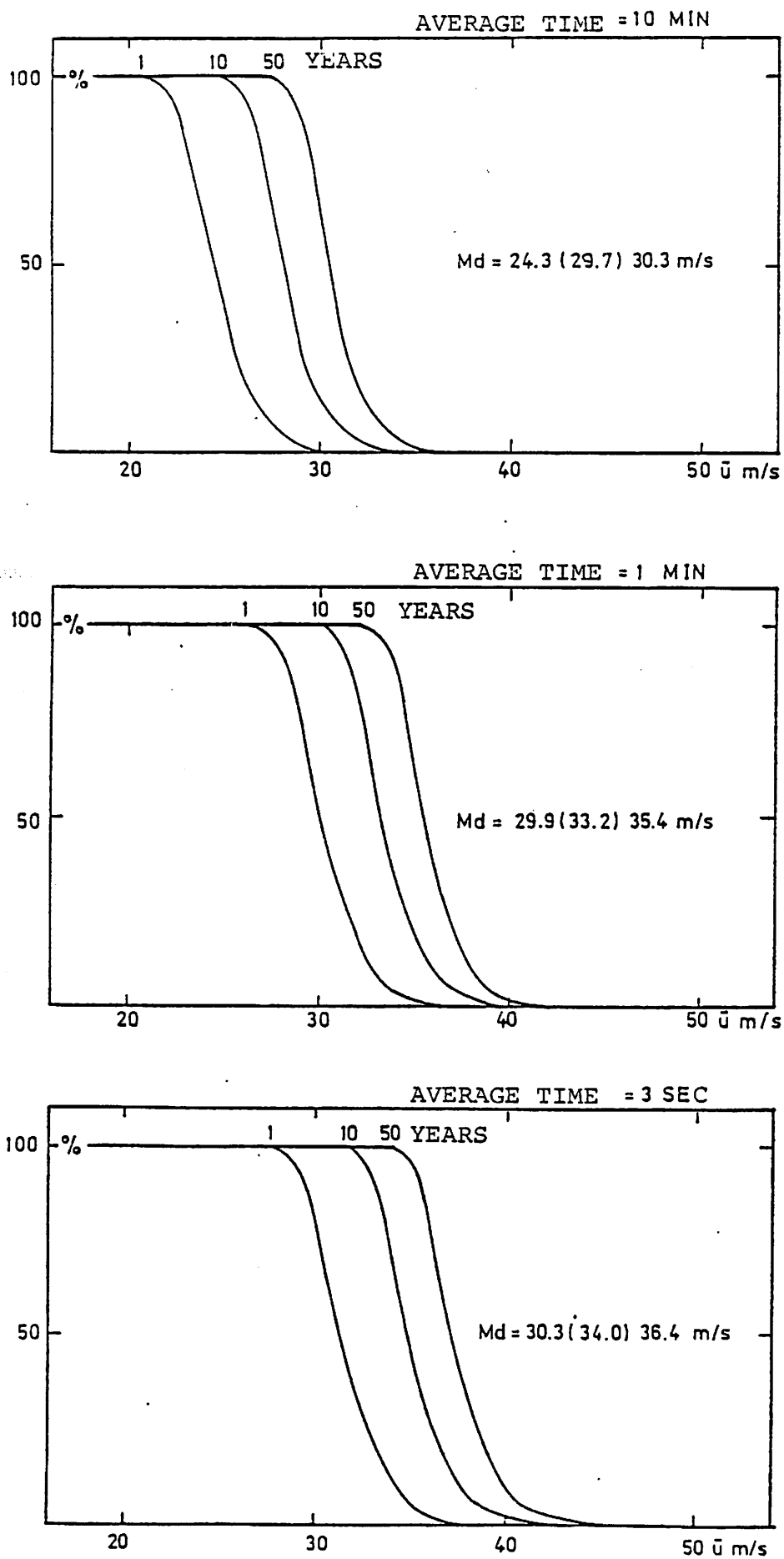

FIG III

SPECIAL TECHNICAL REQUIREMENTS, PREFERENCES AND LOAD CASES FOR  
LARGE WIND TURBINE SYSTEMS.

(Also including "cases of Maintenance and Repair")

This part of the documentation for the VASTVIND projekt is in many parts structured in the same way as the technical tender specification used by NE - the national Swedish board for energy source development - for the construction of the first two large windpower plants in Sweden. However in most details the specification is new. There are also more new specific requirements with regard to maintainability and safety.

(Building windturbines is not as easy as you may believe and still they have to be cheap)

1. General

It is fully recognized that there are many uncertainties in the technology of large scale wind power, however this does not relieve a supplier of a wind energy converter for the VASTVIND project of his responsibility to manufacture, deliver erect and commission a plant that complies with required guarantees, applicable standards and security to personnel and the public. Where reliable information is not available the designer must use his own judgement and apply safety margins that are adequate in his own opinion.

The information given in this document shall be considered as minimum requirements and if these, to the tenderers knowledge, are not sufficient he should inform the purchaser and take up a discussion with the purchaser for a corresponding change of the specification. Likewise the tenderer will be wellcome to suggest a relaxation of requirements that to his knowledge and experience may be too strict.

The wind power plant shall be designed for a life of at least 30 years duty for the rotating system and the control equipment and at last 50 years of duty for heavy load carrying structures (foundation, tower, nacelle bedplates, walls and yaw bearing) - in both cases without change of other components than those that in the tender and the contract will be specified as "wear components" - but provided that all maintenance instructions are followed.

## 2. Operational conditions

### 2.1 Wind characteristics

A wind power plant has to be designed for many locations. The wind characteristics mentioned below should apply to most of the possible sites along the Swedish coastline. In many cases the conditions are likely to be less severe. It should be noticed that the wind characteristics for strength calculations are different from those that will be used for evaluation of production. The density of air is assumed to be  $1,28 \text{ kg/m}^3$ .

(a) Macrometeorological winds - normal conditions.

- (1) Wind velocities and parameters of windspeed profiles and distribution functions are, if not stated otherwise, based on ten minute averages, in this case at 50 m height in each sector,  $i$ , respectively.
- (2) Wind velocity profile is expressed as

$$U(i, z) = U(i, z_{\text{ref}}) \left( \frac{z}{z_{\text{ref}}} \right)^\alpha$$

giving wind velocities at a height  $z$  above ground when the velocity at  $z_{\text{ref}}$  is known.  $\alpha$  is the altitude parameter which in turn is in various sectors and the reference height a function of the surface roughness parameter  $z_0$ . In a "forest" sector  $z$  is calculated from a level 7 m above ground level, and  $z_{\text{ref}}$  is 43 m. The same expression and rules are also used for the height dependence of the scale parameter  $C$  in the windspeed distribution function.

## (3) Wind speed distribution

For that total fraction of a long period - several years - when the wind direction is in a specific sector the wind speed distribution in that sector is described by the Weibul distribution function

$$f(U) = (K/C) \times (U/C)^{K-1} e^{-(U/C)^K}$$

with its corresponding duration curve

$$F(>U) = e^{-(U/C)^K}$$

where

$f(U)$  is the part (in p.u.) of the total sector time when the windspeed is in the interval  $U \pm 0,5$  m/s

$F(>U)$  is the part (in p.u.) of the total sector time when the windspeed is higher than  $U$

$K$  is a shape parameter. For this specification it may be assumed to be constant with height

$C$  is a scale parameter. It is assumed to vary exponentially with height

## (4) Typical site

The typical site is close to a beach and has 3 sectors with different roughness and different wind data.  $U_m$  is the median windspeed which is exceeded 50 % of the time in each sector.

Name of sector	Water	Field	Forest
Time for wind in each sector, % of total time:	40 %	30 %	30 %
Distance and roughness $z_0$ in each sector:	0-500 m 0.05 m	0- 0.2 m	0-100 m 0.2 m
	500 m- 0.001 m		100 m- 0.8 m
$U_m$ 50 m	~ 8.5 m/s	~ 7.0 m/s	~ 6.0 m/s
C 50 m	10 m/s	8.4 m/s	7.4 m/s
K	2.2	2.0	1.8
$\alpha_{10-50}$ m	0.17	0.22	0.29
$\alpha_{50-100}$ m	0.10	0.22	0.33

$U_m$  50 m - the median wind at 50 m height - for all sectors together will be approximately 7.3 m/s

- (5) It will be considered a normal condition that a sharp gradient windshear of  $\Delta U / \Delta z = 0,15; 0,20$  and  $0,25 \frac{m/s}{m}$  occurs during 0,1 % of the time per year in each sector respectively at a windspeed of 2 times  $U_m$  50 m and similarly during 0,01 % of the time per year at a windspeed of 3 times  $U_m$  50 m.



- (6) Fast and small changes of wind direction due to turbulence can be deduced from micro-meteorological wind data mentioned elsewhere.

Synoptic simultaneous changes of wind speed and wind direction have been investigated. This information may be important for the dimensioning of flexible cables and for the jaw operation. The table below indicates typical "twist" distributions for wind speeds above 2 m/s and 4 m/s. A "twist" is defined as one continuous change of azimuth due to synoptical change of wind direction. A clockwise twist is always followed by an anticlockwise twist and vice versa. The "twists" are distributed on classes. Class 3 contains for instance all "twists" between 3 and 4 full quarter turns. The "twists" occur at random.

Twist distribution for wind speeds  $\geq 2$  m/s

Nr of full quarter turns															Nr of twists	Nr of turns
	1	2	3	4	5	6	7	8	9	10	11	12	13	14		
Clock- wise	42	21	5	10	5	1	3	0	1	1	1	1	0	1	92	61 3/4
Anti- clock- wise	55	87	4	2	3	2	0	0	0	0	0	0	0	0	93	39

The difference in number of full turns is 22 3/4 clockwise.

Twist distribution for wind speed:  $\geq 4$  m/s

Nr of full quarter turns															Nr of twists	Nr of turns
	1	2	3	4	5	6	7	8	9	10	11	12	13	14		
Clock- wise	27	17	4	2	8	4	0	0	0	1	0	0	0	0	63	38 3/4
Anti- clock- wise	30	20	9	2	3	0	0	0	0	0	0	0	0	0	64	30

The difference in number of full turns is 8 3/4 clockwise.

50 complete turns per year and that the direction of each turn will be random.

(b) Macrometeorological winds - extreme windspeeds

- (1) Extreme wind velocities, at 50 m height, to be used in the load calculations:

$U_{E1} = 50$  m/s. Highest mean wind velocity to be considered during 3 seconds when the WTS is in perfect condition. Applied as an instantaneous gust.

$U_{E2} = 41$  m/s highest mean wind velocity to be considered during 1 minute when the WTS is in perfect condition and during 3 seconds at the appearance of a critical fault. Applied as instantaneous gusts.

$U_{E3} = 37$  m/s highest mean wind velocity to be considered during 10 minutes.

$U_{E4} = 26$  m/s highest mean wind velocity to be considered during 10 minutes when personnel might be inside the nacelle.

- (2) Extreme wind velocity - height profiles

In the height interval 10 - 150 m, the following expression is assumed to hold for extreme wind velocities:

$$U_E(z) = U_E(z_{ref}) \left( \frac{z}{z_{ref}} \right)^\alpha$$

where  $\alpha$  is assumed to be 0.07 for 3 second winds 0.1 for 1 minute winds and 0.13 for 10 minute winds.

## (3) Extreme changes of wind direction

For this tender it shall be assumed that a  $90^{\circ}$  change in average wind direction can take place in 2 minutes at any windspeed below 10 m/s. For higher windspeeds, no such changes of direction are assumed except for what can be deduced from turbulence formula stated elsewhere. There is no supporting statistics available.

## (c) Macrometeorological wind velocity for theoretical calculation and evaluation of production performance.

For evaluation of the wind/power curve the following "standard wind" will be used

$$\begin{aligned} U_m 50 \text{ m} &= 6 \text{ m/s} \\ C 50 \text{ m} &= 7.2 \text{ m/s} \\ K &= 2 \\ \alpha_{10-100} &= 0.2 \end{aligned}$$

The data is assumed to be based on 10 min averages. The windshear and turbulence of the "standard wind" shall be based on a ground roughness of  $z_0 = 0,3$  in all directions.

## (d) Micrometeorological wind velocity - normal conditions

The micrometeorological wind velocities (or turbulence) shall be superimposed on the ten minutes mean wind velocity  $U$  at the height  $z$ .

The turbulence is described in the rectangular coordinates:

$u$  = longitudinal wind velocity in the main wind velocity direction

standard air  
density 1.225 kg/m<sup>3</sup>  
1013 hPa

$v$  = lateral wind velocity positive to the right,  
and

$w$  = vertical wind velocity positive downwards.

The turbulence is described by the spectral functions

$$\sigma_j^2 = \int_0^{\infty} S_j(n) \, dn, \text{ where}$$

$j \in (a, v, w)$

$\sigma_j^2$  = the variance

$n$  = the frequency in Hz.

(1) Gust spectra

Longitudinal

$$\frac{n S_u(n)}{u_*^2} = \frac{105f}{(1+33f)^{5/3}}$$

Lateral

$$\frac{n S_v(n)}{u_*^2} = \frac{17f}{(1+9.5f)^{5/3}}$$

Vertical

$$\frac{n S_w(n)}{u_*^2} = \frac{2f}{(1+5.3f)^{5/3}}$$

where  $f = \frac{n \cdot z}{U}$

$$u_* = 0.4 U / \ln(z/z_0)$$

$z_0$  = the roughness parameter of the sector.

$z_0 = 0.3$  for "field" and  $0.6$  for "forest". In the "water" sector  $z_0 = 0,02$  below hub height and  $0.001$  above hub height.

$z$  = height above ground. In the "forest" sector  $z$  is calculated from a level  $7$  m above ground.

## (2) Probability density function

The three components (u, v, w) of the wind are assumed to be normally distributed.

## (3) Cross spectra

The coherence function Coh, is defined as

$$\frac{C_o^2 + Q^2}{S_1 \times S_2}$$

where  $C_o$  is co-spectrum  $Q$  quadrature-spectrum and  $S_1$  and  $S_2$  spectra for two points in space. All the spectra are functions of  $n$ .

Coh follows approximately the equation:

$$\text{Coh} = e^{-a \times n \times D/U} \text{ where:}$$

$D$  = vertical or lateral separation of two points in space

$U$  = average of the wind velocities for the two points

$n$  = frequency

$a$  = 25 for lateral Coh of u and 12 for lateral Coh of v

$a$  =  $30 \times (D/z)^{0,45}$  for vertical Coh of u and  
 $15 \times (D/z)^{0,45}$  for vertical Coh of v.

Both the lateral and vertical coherence for the vertical component w is small and negligible for interesting values of  $D$ .

## (e) Micrometeorological wind velocity - extreme winds

No additional turbulence has to be considered with the extreme winds.

- (f) Micrometeorological wind velocity for theoretical calculation and evaluation of production performance.

The turbulence to be considered in this case shall be based on a "standard ground roughness" of  $z_0 = 0,3$ .

## 2.2 Environment

The WTS may be assumed to be situated at an altitude between 0 and 200 m above sea level.

For design and construction of WTS and its subsystems the following environmental conditions shall be met:

- (a) Temperature, pressure, humidity

- (1) Air temperature at hub height

Average distribution over the year:

North Swedish coasts

max = + 30°C

> + 25°C < 50 h

> + 15°C < 1200 h

< 0°C < 3600 h

< - 10°C < 1100 h

< - 25°C < 150 h

min = - 35°C

South Swedish coasts

max = + 30°C

> + 25°C < 150 h

> + 15°C < 2300 h

< 0°C < 1900 h

< - 10°C < 200 h

< - 20°C < 30 h

min = - 25°C

- (2) Average rate of change of air temperature during 24 hours  $\pm 2^\circ\text{C/h}$

- (3) Absolute air pressure 930-1065 mbar

- (4) Average value of relative humidity for one month  
max 90 %  
min 70 %

Maximum relative humidity during short periods  
is 100 %

(b) Rain, snow, hail, and ice

- |     |      |  |              |
|-----|------|--|--------------|
| (1) | Rain | Normal heavy rain  | 30 mm/hour   |
|     |      | Extreme rain (once in<br>10 years)   | 9 mm/3 min   |
| (2) | Snow | Relevant data not clarified  |              |
| (3) | Hail | Number of days/year  | 4            |
|     |      | Normal hail size/speed   | 5 mm/9 m/s   |
|     |      | Extreme hail size/speed  | 20 mm/20 m/s |
|     |      | Hail intensity is the same<br>as rain intensity                                |              |
| (4) | Ice  | Super cooled rain and other<br>risks for ice formation,<br>number of days/year | 4            |

(c) Corrosion

Corrosive atmosphere corresponding to M3 in "Rostskyddsnorm StBk-N4, Statens Stålbyggnadskommitté" (Swedish code on corrosion protection of steel structures StBk-N4, the National Swedish Committee on Regulations for Steel Structures). In addition it must be mentioned that the WTS will be installed so close to the sea that the climate will be of pronounced marine type with a high content of chlorides in the air and some direct spray of salt.

(d) Dust

The air will occasionally carry abrasive dust with particle size up to 0,01 mm and non abrasive dust





nings. For the calculations the data in each column shall be considered as characteristics of one and the same lightning which is not necessary the case in reality.

A lightning may strike any point on a structure - not only blade tips - that can be touched by a sphere of radius  $R_B$  falling from the sky at an angle of  $20^\circ$  degrees from the vertical.

$$R_B = 2 \times I_{\max} + 30 (1 - e^{-I_{\max}/6.8}).$$

The relative probability for a strike in a certain section of the plant can be reasonably estimated assuming that spheres are falling with an even spread over the wind power site.

It is also important to consider small lightnings.

Characteristics of small lightnings.

	Normally small	Unusually small	Extremely small
maximum current I (kA)	8	6	4
current rate of change di/dt (kA/micros)	10	6	4
charge $Q = \int i dt$ (As)	3	1	0,6
action $P = \int i^2 dt$ inte- gral (Ws/ohm)	$10^4$	$2.5 \times 10^3$	$10^3$
radius of lightning sphere $R_B$ (m)	37	30	20

10 % of all lightnings may be assumed to have values less than "Normally small", 2 % values less than "Unusually small", and 0.5 % values less than "Extremely small".

The plant must be unaffected by a "Normally small" strike. Slight damage is acceptable with "Unusually small" but the plant must not lose any function even after two consecutive such strikes. Damage shall be calculated for "Extremely small" lightnings.

The small lightnings will be considered to hit at the most unfavourable spot on the plant that can be touched by the corresponding lightning sphere.

### 2.3 Ground

The ground for the foundations may be assumed to be morain in the main alternative but unfissured bedrock and clay must be considered as well. Details of the ground quality will be submitted after final site selection.

### 2.4 Roads, transportation and site preparation

- (a) Maximum dimensional and weight limitations for Swedish roads shall be met for transportation on public as well as private roads, including legally allowable exemptions.

The transport limitations - including vehicle - on Swedish public roads are normally as follows; length 24 m, width 2.5 m, height 4.5 maximum pressure per wheel-axis 10 t per boggy 16 t. There are however often variations in these - both higher and lower. Exceptionally, under certain conditions, it may be possible to receive a permit to exceed the transport limitations.

It is the responsibility of the tenderer and contractor to examine all transport conditions

up to the site when it has been finally selected and to include all the transport costs in the price.

Information on limitations and permits can be received from the National Swedish Road Administration (Statens Vägverk), the County Administration (Länstyrelsen) or the municipality (kommun) concerned, who are all in charge of various parts of the road system. On private roads the owner must give permission before any transport.

- (b) In case there is no final useful access road to the site such a road will be prepared by the purchaser to carry the maximum tendered transport weights. The cost of such a road will be considered in the tender evaluation.
- (c) The site area - to be defined in the tender and contract - will be cleared of trees and brush and if required also levelled by the purchaser. Ground reinforcement to carry transport and erection weight will however be the contractors obligation.

## 2.5 Electrical network

- (a) The wind power plant generator is assumed to be connected to a 3-phase AC network with other power sources where the following applies:

- (1) Nominal frequency 50 Hz
- (2) Frequency variation
  - (i) normal  $\pm 0.1$  Hz

- (ii) at fault conditions,
  - continuously  $\pm 1$  Hz
  - rate of variation 0.5 Hz/s
- (iii) at extreme fault
  - limited duration  $\pm 2.5$  Hz
  - rate of variation 1 Hz/s

Note: Lower and higher frequencies may occur for considerable intervals. The electrical network is then considered as being out of function.

- (3) Nominal line voltage  
(site dependent, to be specified later)  
10-24 kV

- (4) Voltage variation
  - (i) normal operation  $\pm 5$  %
  - (ii) at fault condition - 15 %  
(long duration) + 10 %

Note: Lower voltage and/or loss of voltage may occur.

- (5) Short circuit power level from the network. (Site dependent, to be specified later). Generally less than 200 MVA at 10 kV and less than 500 MVA at 24 kV.

- (6) Insulation level according to SEN 21 05 10.

- (7) The risk for subsynchronous oscillations shall be considered from case to case.

- (b) The wind energy plant auxiliary power supply is assumed to be connected to the same 3-phase

HV-line as the generator. It must be pointed out that the power supply will not be fully reliable and that disturbances and power cuts are most likely to occur in situations of high winds and other extreme climatic conditions.

- (c) During the erection work 400 V AC 3-phase 50 Hz will be available on site under conditions detailed elsewhere in the documentation.

## 2.6 Telecommunications

- (a) The plant will be connected to the national telephone system by one line that may be used for remote transmission of functional data on a discontinuous basis. Remote transmission and control equipment is however not part of the tender but may be included later.
- (b) During the erection work a telephone line will be available on site under conditions detailed elsewhere in the documentation.

### 3. Power curve, operational parameters. Modes of operation

#### 3.1 Power curve - guarantee

The tendered power curve - i.e. total output power versus free windspeed - together with the hypothetical "standard wind" (2.13, 2.16) yield a hypothetical "tendered annual energy production" which is to be guaranteed by the contractor within a certain symmetric accuracy margin. The power curve, the mathematical formulae and the accuracy margins shall be stated in the tender. The guarantee construction is described in detail elsewhere in the documentation.

The tenderer will as an alternative be permitted to guarantee other data or operational parameters such as single points on the power curve, starting and stopping winds, rated windspeed, rated power etc as long as he can provide acceptable formulae for relating these and deviations in these to the annual energy production with the "standard wind". Accuracy margins shall be symmetric. Methods of measuring shall be suggested.

#### 3.2 Modes of operation

The number and types and denominations of modes are to be decided by the contractor. However for the purpose of this specification the following main modes are defined.

"Locked"            The WTS is positively locked in jaw or rotation or both. The reason could be due to maintenance work or waiting for repair.

"Off"

The WTS is shut down due to a fault or the setting of a local manual switch or a remote blocking signal. It can not start unless the fault is cleared and protections reset or the switch turned or the blocking removed. The WTS may however be free to yaw and follow the wind, even by using a motordevice and the turbine may be free to move at a reduced idling speed if this is found advantageous.

"Stand by"

The WTS is completely prepared to produce power but the wind conditions are unfavourable. Two sub modes can be considered depending on whether the wind is unfavourably low or unfavourable high.

"On line"

Connected to the network.

In addition to these there could be intermediate transition modes as well as emergency condition modes (emergency for equipment, emergency for people).

It is a general wish that the number of modes shall be kept low.

#### 4. Special technical requirements

Requirements with technical implications are also mentioned elsewhere in the complete set of tendering documents.

In this chapter a limited number of technical requirements and some preferences are presented. When formulating these a wind power plant that is simple and easy to maintain has been envisaged, without station batteries, with a turbine that is normally free in rotation when not operating to keep down extreme loads, a plant that does not need very large mobile cranes neither for erection nor for later service and repair. The purpose is to achieve a low cost of energy. For this reason these requirements and preferences should not be considered as strict rules but more as a check list and by referring to them the contractor will not be relieved of his responsibility to supply a well functioning and safe plant.

Deviations implying relaxation of the requirements in this chapter are allowed but must be well motivated in writing and agreed on before contract. The same applies to deviations from stated preferences. The purchaser will favour unconventional designs and methods which can be proved to reduce the number of components, increase availability, cut down investment and maintenance cost but without an unacceptable increase of risk to personnel or the public.

##### 4.1 Applicable design codes and standards

- (a) It is the responsibility of the tenderer - contractor to keep himself informed about the standards and rules that apply in Sweden. The list mentioned below is not complete but only



an example to help the contractor. Also some foreign standards are mentioned as "being applicable".

Deviations from applicable design codes and standards or the use of alternative codes and standards must be agreed upon before signing of a contract.

Regarding change of standards and rules imposed by authorities after the tender closing date reference is made to the general conditions.

(b) Applicable design codes and standards include for instance:

- (i) Svensk Byggnorm, SBN 1980, Statens Planverk (Swedish Building Code, the National Board of Physical Planning and Building).
- (ii) Bestämmelser för betongkonstruktioner Statens Betongkommitté (Regulations for Concrete Structures, National Swedish Concrete Committee).
- (iii) Stålbyggnadsnorm 70, StBK-N1, StBK-N1/S1, Statens Stålbyggnadskommitté (Regulations for Steel Structures, the National Swedish Committee on Regulations for Steel Structures).
- (iv) Byggsvetsnormerna, StBK-N2, Statens Stålbyggnadskommitté (Swedish Structural Welding Code, the National Swedish Committee on Regulations for Steel Structures).

- (v) Skruvförbandsnorm, StBK-N3, Statens Stålbyggnadskommitté (Swedish Code for Bolted and Riveted Joints, the National Swedish Committee on Regulations for Steel Structures).
- (vi) Rostskyddsnorm, StBK-N4, Statens Stålbyggnadskommitté (Swedish Rust Code).
- (vii) "Svetsade aluminiumkonstruktioner". Försöksnorm och kommentarer utarbetade av Svetskommissionen i samarbete med SVR:s Aluminiumnormkommitté (1971).
- (viii) Svensk Standard, Metallnormcentralen (Swedish Standard, Swedish Metals Standards Institutions).
- (ix) ASTM specification of thin sheet, B203 (American Society of Testing and Materials).
- (x) Det Norske Veritas, Rules for building and classifying of steel ships 1977. Part VI paragraph 5, Rule proposal RM-11-77, Rev 3 - Reduction gears.
- (xi) Tryckkärlsnormer 1973 - Normer för hållfasthetsberäkning av tryckkärl med supplement 1:1976 (Pressure Vessel Code 1973, the Swedish Pressure Vessel Commission, the Swedish Academy of Science).

- (xii) Rörledningsnormer 1978 - Normer för rörledningar i stationära anläggningar. (Piping Code 1978, the Swedish Pressure Vessel Commission, the Swedish Academy of Science).
- (xiii) Lyftdonsnormer, IVA Kran- och hisskommission.
- (xiv) Arbetarskyddsstyrelsen anvisningar nr 58, 63 och 92.
- (xv) Svenska Elektrotekniska Normer, SEN, Svenska Elektriska Kommissionen (Swedish Electrotechnical Standards, the Swedish Standards Commission). IEC standards shall be applied if SEN standards are incomplete.
- (xvi) Starkströmsföreskrifter enligt författningssamlingar från Kommerskollegium och Statens Industriverk, KFS 1960:8, SIND-FS 1975:2 and SIND-FS 1976:10 (Rules för electric installations from the National Industrial Board and the Swedish Board of Commerce).

(c) For designs where no available codes can be correctly applied sound methods of analyses shall be used.

#### 4.2 Wind turbine (blades, hub) and main shaft

- (a) The blade design shall allow for proper balancing both during manufacturing and after commissioning in case of modifications and

repairs. A description of balancing methods to be applied shall be provided by the contractor.

- (b) Provisions shall be made for regular inspection of all zones and joints with high stress in relation to permitted limits and all bearings and linkage systems, without having to dismatle components that are heavy or otherwise difficult to handle. A description of inspection methods shall be provided by the contractor. It shall be possible to use objective methods to verify the state of highly stressed zones and joints.
- (c) Means for venting of turbine blades shall be provided. Places where water may collect shall be self draining.
- (d) Bearings shall be arranged in a way to prevent ingress of water from condensation, rain or snow and there shall be provisions for convenient collection of leaking oil and oilmist as well as used grease.
- (e) Flange joints shall whenever possible be arranged inwards. If this is not possible bolts, screws and nuts must be given an adequate protection.
- (f) Highly stressed joints between fibre reinforced polymeric materials and metals shall be designed with due regard to the difference in mechanical and chemical properties of the materials. Each joint shall be made using at least two but preferably all three of the methods glue, bolts and positive locking by

shape. Each method shall be strong enough to endure the applicable loads with appropriate safety margin. Bolts may be used alone if the applicable loads can be carried by only half the number of bolts and still with appropriate safety margin. Glue must be of a quality that has been well tested in similar applications. Drawings, stress analyses and life calculations for all such joints shall be provided by contractor. Special attention is drawn to any problems of gluing surfaces with properties that might be affected by small amounts of water and oxygen that may reach the joint region by diffusion through the bonded materials.

- (g) It shall be possible to make adjustments to compensate for differences between blades in aerodynamic performance.
- (h) The turbine control system shall have sufficient mechanical and operational strength to make the operation of the wind power plant unaffected by a 50 mm icelayer covering all mechanisms out in the open air and a 20 mm icelayer simultaneously covering all movable joints on one side of blades and half the circumference of any joints between blade roots and hub.

If the turbine control system can not be moved due to thicker icelayers or is jammed for other reasons there must not be any mechanical damage to equipment due to operation attempts and the wind power plant shall be shut down to the "off" mode. It shall later be possible to arrange for a long time delayed automatic restart after such a shut down.

- (i) Any hydraulic or pneumatic components in the turbine control mechanism shall be easily accessible for check up, maintenance and exchange and should preferably be mounted inside the nacelle.
- (j) Emergency aerodynamic braking shall be effected using energy stored in compressive springs and/or the effect of centrifugal or aerodynamic forces. Hydraulic pneumatic energy storage for emergency - including gas springs - is only allowed if the operation ability is automatically monitored and if long term high reliability is proven under relevant climatic and maintenance conditions and only in combination with a system using mechanical compressive springs, centrifugal or aerodynamic forces to assure that the wind turbine is permanently kept in the "off" mode after emergency tripping.
- (k) Aerodynamic braking must be possible with the braking arrangements of only one blade in operation and the turbine shall then be put to a stop or to a speed of rotation that even at the highest windspeed  $U_{E1}$  does not exceed the rated speed and at  $U_{E3}$  does not exceed the speed for closing the mechanical brake. These requirements may be eased to apply for all blades together if their air braking arrangements are all interconnected by a linkage system of extremely high reliability (fail safe) that will function even in case of neglected maintenance. The probability of linkage failure shall be calculated and it shall be very low similar to or better than required for primary structural components.
- (l) Braking by yawing of the turbine is allowed as back-up but not required.

- (n) The turbine shall in addition to electronic over speed protection be equipped with a back-up mechanical centrifugal device that will directly initiate aerodynamic braking but not necessarily a complete stop.
- (o) It shall be possible to mechanically lock the turbine in a number of predetermined positions using a manually operated positive locking device.

It shall be possible to perform the locking operation in windspeeds up to  $U_{E4}$  and the locking device must thereafter be able to keep the turbine locked in rotation up to  $U_{E1}$ , even if this leads to risk for damage to the turbine itself.

The locking device - or a special device that is temporarily mounted - must be able to keep the turbine locked in windspeeds up to 12 m/s measured as the average over 10 minutes with any number of blades missing and in a number of predetermined positions dictated by erection and dismantling procedures.

Locking devices must not act through the gearbox but directly on the turbine hub or the main shaft.

- (p) The turbine shall be equipped with an inching device capable of turning it around and holding it temporarily in any position and in windspeeds up to  $U_{E4}$ . It shall also be possible to use the inching device - or a special device that is temporarily mounted - for turning the turbine with any number of blades missing to a number of

predetermined locking positions dictated by erection and dismantling procedures and in windspeeds up to 12 m/s measured as the average over 10 minutes.

- (q) The turbine blades shall be painted with the colourmarkings required by Swedish aviation authorities.
- (r) Other methods of control than pitching the whole or part of the turbine blades are acceptable if the performance will be comparable.
- (s) For maintenance reasons there is a preference for designs using bearings and linkage joints of types that do not require regular lubrication e g elastomeric or completely sealed types.
- (t) The blades shall be equipped with a lightning protection system that will meet requirements specified elsewhere. Generally for conductive paths, bars or wires are preferred to platted straps wherever possible as being less sensitive to contractive forces at high currents.
- (u) For a turbine with teetering or flapping blades it is preferred if automatic locks for the teetering or flapping movements are not needed when the turbine is stopped or rotating at low speed. Temporary locking arrangements are however required during erection or maintenance. Such locking arrangements may be manual if designed with regard to maximum weights that can reasonably be handled when working in the hub section. End position stoppers or dampers for teetering or flapping blades shall be designed with elastomeric materials.



#### 4.3 Gearbox

- (a) The gearbox must be designed for the operational duty of the plant and with special regard to the requirements and conditions set by other parts of the wind energy conversion system.
- (b) A planetary type of gearbox is preferred as this is judged to lead to lower total plant cost in future larger windpower plants.
- (c) The lubrication system for the gearbox must be designed with regard to that there shall not be any DC batteries or other types of stand by power supply suitable for pump drives in the windpower plant. Only AC power from the mains will be available and it is not completely reliable. This requirement will have special implications in case of "free idling" wind turbines.

#### 4.4 Generator

- (a) The generator shall be of induction type, with squirrelcage rotor, screen protected and splash proof (IP23). Double generators or a polechange generator is acceptable for a two speed system. The generator shall have roller bearings and a large terminal box. The neutral end of the winding shall be accessible in the terminal box. The winding shall have at least 3 embedded temperature sensors wired out to suitably located connection terminals.
- (b) The generator shall be able to endure repeated maximum turbine overspeeding at loss of load.

#### 4.5 Turbine brake

- (a) The windpower plant must be equipped with a mechanical brake, which is to be designed for the operational duty of the plant and with special regard to the requirements and conditions set by the turbine and the gearbox.
- (b) The mechanical brake together with a functioning airbrake system must be able to bring the turbine to a complete stop and hold it in windspeeds up to  $U_{E3}$ .
- (c) The mechanical brake alone must be able to hold the turbine at least temporarily in windspeeds up to  $U_{E4}$ .
- (d) A design is preferred where the brake is mounted on the high speed shaft in the drive train and only intended for temporary holding of the turbine. A brake that may even accidentally - due to power failure or equipment failure - hold the turbine for longer time must act directly on the slow speed shaft.
- (e) The brake system must be designed with regard to that there shall not be any DC batteries or other type of standby power supply suitable for brakes in the windpower plant. Only AC mains will be available and it is not completely reliable.

#### 4.6 Nacelle

The machinery shall be mounted in a housing to give climatic protection both to equipment and personnel.

- (a) The nacelle must be heat and soundinsulated using maintenance free noninflammable materials.
- (b) There shall be two windows that can be opened from the inside and located to permit observa-tion of the turbinblades. There shall also be one hatchway to give access to the roof. It shall be possible to open the hatchway from both inside and outside.
- (c) There must be adequate working space for all people required - at least three - at mainten-ance work and at exchange of heavy machinery.
- (d) The nacelle must have a lifting device for dis-mantling all the equipment inside and lowering to the ground as well as hoisting and mounting. The device shall, with eventual attachements, be able to handle the largest single component to be dismantled in case bearings on the turbine rotor must be changed. The device must be able to handle equipment both inside and outside the tower and also be safe enough to be used - with eventual attachments - for lifting a slingbasket with two persons for maintenance and inspection of all sides of turbine and tower. This basket, suitable for outdoor storage, is to be included in the supply. As the tower might sway, it must be possible to secure the lifting device in a suitable parking position. Attention shall be paid to the eventual need of light lifting capacity for tools and instrumentation in situations when the main lifting device is occupied.
- (e) For painted surfaces on the load carrying frame of the nacelle the same requirements shall apply as for the tower structure.

- (f) Flooring inside the nacelle shall be of anti-slip type.
- (g) The equipment shall be arranged in suitable assemblies - e g in steelframes - that can be handled as self contained units during erection and dismantling. However it shall also be possible to change separately each single component that has a certain risk for failure or that needs regular maintenance and check up. All hydraulic pumps and hydraulic controls should preferably be in one unit, all lubrication pumps and controls in a second unit and all electronic controls and relaying equipment in a third unit. Separately mounted small pieces of equipment should be avoided.
- (h) All places where oil leaks are likely to occur shall have spillplates with capacity for substantial quantities of oil. In no way shall there be any possibilities for oil leaks - except in case of rupture of metal pipes - to trickle down inside the tower.
- (i) There shall be arrangements for collecting oil-mist from bearings and hydraulics and provisions for collecting old grease from any grease lubricated bearings.
- (j) On the roof of the nacelle there shall be warning lights as requested by Swedish aviation authorities.
- (k) The nacelle shall be able to yaw, turning on a bearing arrangement. If large diameter bearings of slewing crane type are selected it must be possible to take out the balls or rollers from

inside the tower for inspection and eventual change.

- (l) The yawing movement shall be controlled by a drive for turning the rotor into or out of the wind as the case may be and/or untwisting any flexible cables in the tower. For an active yaw machine the drive shall be able to turn the nacelle 360 degrees when operating at any windspeed in the operation range. For a down wind, in duty normally free yawing turbine, the upper wind speed for operating the yaw drive is  $U_{E4}$  while the turbine is idling, held by brakes or locked as specified by the manufacturer. Automatic yawing for untwisting of any cables may be limited to lower windspeeds to avoid energy loss and excessive mechanical wear.
- (m) The yawing motion for a free yawing wind turbine must be sufficiently damped with regard to security for personnel in the nacelle and gyroscopic loads.
- (n) A yaw brake system for permanent duty is required for an active yaw machine and shall be able to hold the unit in any position and at any intended combination of operating mode and windspeed in the range up to  $U_{E3}$ . The brake may act on the yaw motor only if mechanical play in mechanisms can be avoided. A yaw brake system is also required for a normally free yawing turbine but only for temporary duty and with ability to hold the unit in windspeeds only up to  $U_{E4}$ . This brake may act on the yaw motor if mechanical play does not decrease the service life of any components nor interferes with a subsequent locking operation.

The brake must be allowed to slip above the holding limit.

- (o) A positive manual yaw locking device must be supplied, capable of locking the nacelle in at least six directions and holding it locked in windspeeds up to  $U_{E1}$  with the turbine both idling or locked even if this leads to a risk for a certain limited damage to the wind power plant itself. It must be possible to perform the manual locking operation in windspeeds up to  $U_{E4}$ . A simple device - type bolt in hole - is preferred but mechanical play must be kept to a minimum.
- (p) The nacelle shall have 220 V AC lighting and sockets for connection of electric handtools and a 24 V AC insulating transformer with sockets for connecting tools and lighting to be used for working inside the hub or other compartments or on platforms outside.
- (q) The nacelle shall have a telephone system with a standard receiver and also with a head set and an extension cable for communication with the ground level from any place inside.

#### 4.7 Tower and tower foot

- (a) Concrete shall be of a quality with proven resistance to ingress of saltladen moisture and surface deterioration, or it must be given a surface protection to achieve the same properties.
- (b) Steel must be given a protective surface coating of a type that is adequate for the material

selected in a corrosive and deteriorating marine environment and that can be touched up later on site to a similar standard at ambient temperatures down to + 10°C. Information on expected touch up periods shall be given and a description of the work.

- (c) The main volume of the tower must be well ventilated through air intakes at the bottom and air outlets close to the top to prevent the accumulation of hot air during warm summer days when maintenance is most likely to take place. The need for ventilation is more pronounced with steeltowers.
- (d) The tower shall have internal ladders with resting platforms at intervalls.
- (e) Just below each erection joint in a steel tower there shall be brackets on the inside or holes that may be used for installing an internal working platform for inspection of the joint area.
- (f) Flanged joints should preferably be on the inside of the tower. If arranged on the outside accumulation of water and dust must be prevented and a very strong corrosion protection must be applied. Threads of any pinscrews in the bottom flange must be mechanically protected.
- (g) The standard design of the tower shall be without an elevator. However an additional price shall be given for installing an elevator for 2 men either inside or on the outside of the tower. A construction type of elevator is acceptable and it is not required that the

elevator should be permanently installed. A period of 5 years is sufficient.

- (h) The tower shall have normal 220 V AC lighting and sockets for connection of electric handtools at various levels and arranged close to the ladder.
- (i) Electric power and control signals between the nacelle and the foot of the tower should preferably be transmitted by electric cables flexible in twist. The cable design shall allow alternate twisting back and forth in each direction a large number of times. The duty for the cable depends on the wind characteristics mentioned elsewhere and on the setting of windspeed limits for cut-in, cut-out and rewinding.
- (j) Reinforcement steel and prestressing cables of a concrete tower shall be in good contact with the grounding system and must also be electrically interconnected to form a cage to screen off some of possible electromagnetic disturbances. In addition, for concrete sections, a special lightning path to ground shall be arranged on the outside.

#### 4.8 Foundation

The foundation shall be included. There are no special requirements other than

- (a) The foundation must be designed with regard to earthing of the unit.
- (b) Strain gauges shall be installed in at least two places on the reinforcement steel or prestressing cables.



#### 4.9 Electric system, control system, earthing and lightning protection

- (a) The need for reactive power compensation of the asynchronous generator will be decided when the final location has been selected and suitable equipment shall be quoted separately. Important is that the electric system must be built so that the risk for self-excitation between the generator and the capacitor bank is eliminated. This risk must be especially observed with double speed wind turbines since wrong switching can lead to an electrical overspeed situation without mechanical overspeed.
- (b) Each power system must have an adequately earthed neutral point to prevent the building up of uncontrolled voltage levels and lightning arresters or similar must be installed in order to prevent any unexpected overvoltage phenomenon in connection with lightning strikes.
- (c) Circuitbreakers, contactors and relaying shall to the highest possible extent be selected for AC supply. Tripping power for circuit breakers shall be taken from the AC local power system via capacitor devices to avoid the installation and maintenance cost of a large station battery and DC system.
- (d) Only a small low voltage battery and DC system (24 V) will be allowed for supply to certain electronic equipment. However it is preferred if even this can be avoided.
- (e) There shall be only one common protective grounding system built up with separate earthing

bars and wires in good direct metallic contact with cubicles, enclosures and all metallic plant structures. Generally protective earthing of equipment must not be through other equipment or structures but directly by adequately sized copper wire to the grounding system. Exceptionally other methods to achieve durable and adequate electric contact with the grounding system may be accepted but only after safe demonstrations. Attention must be paid to mechanical vibrations.

Adequately dimensioned barred grounding electrodes of the system shall be included in the supply as well as adequate measures to achieve a low safe step voltage in outdoor switchgear areas and a low safe potential difference between the ground surface and metallic parts at the base of the tower. The grounding system shall be able to endure lightning currents.

- (f) Lightning protection of the turbine has been mentioned before. (4.2). Lightning conductors and brush systems must be installed to ensure that lightning currents do not pass through sensitive parts such as bearings, links, joints and electric equipment. The whole lightning protection system including that of the turbine shall be able to endure "Normal" lightnings without any damage. For "Unusual" lightnings small damage is acceptable but the system must not be rendered inoperative and shall be able to function without need for immediate repair. Extreme lightnings may cause large damage to the lightning protection but not to the rest of the total windpowerplant. The likely effects of an

extreme lightning shall be calculated. The lightning protection system shall be connected to the common protective grounding system.

A lightning counter shall be installed to register any direct lightning strikes in the windpowerplant.

- (g) A separate signal earthing system connections between this and the protective grounding system shall be arranged to minimize electric disturbances. Galvanic insulation for incoming telephon line and remote control will be provided by the purchaser shall be included.
- (h) Generally it is a wish that the control system should have as few components as possible to increase the reliability and to cut costs. The complexity of the controlsystem will play an important part in the total evaluation.
- (i) There shall be two places for operating the windpower plant, one in the nacelle or at the top of the tower and one close to or at ground level. The supplier is free to suggest the type and number of of controls and controlfunctions. However they must be well described and specified in the tender. Manual operation of all movements, drives, pumps and motors shall be possible for maintenance and fault location. The controls may be distributed between the two levels at the suppliers choice however the following operations must be possible to perform at any level:

- Switch on to "Stand by" mode from "off" mode.

- Switch to "Off" mode from any other mode except "Locked".

The "Off" position shall be overruling.

It must be possible to prevent inadvertent or unauthorized operation of controls by some kind of key and lock arrangement.

- (j) Voltage, current, power, produced and consumed energy shall be indicated at ground level. Accumulated energy production and consumption shall be independent of the controlsystem.
- (k) There shall be counters for number of revolutions with capacity up to at least  $10^9$  and for number of operating hours. Both shall be independent of the controlsystem.
- (l) The minimum number of signals that need to be remote transmitted are "general fault", "fire" and "unit in operation". Transmission possibilities for other signals is optional. The signal transmission equipment will be supplied after erection by the purchaser.
- (m) A minimum number of sensors, limit switches and relays shall be used. For this reason it is preferred that all deduced variables such as e g power and powerfactor and integration of variables over time and acceptable levels are formed inside a single computerized control system. However there must be a back-up protection system of conventional electromagnetic type. Some variables indicative of serious faults that may quickly lead to disastrous effects e g large vibrations and unbalance, earth faults, short

circuits must initiate a shut down procedure which does not depend on a computer system. Maximum overspeed shall initiate shut down through a mechanical device as a back-up to any other overspeed protection.

- (n) Signals to and from the control system shall be filtered and protected against induced transients and they must be accessible for measuring on test terminals.
- (o) For surveillance of the plant operation it shall be possible to tap the control system of in-put and out-put signals and deduced variables without using the above test terminals.
- (p) The control system shall be built up from whole standard hardware units supplied by internationally recognized manufacturers and used also in other applications than for windpower.
- (q) All programming must be in a generally well known high level language. The same language for all computer systems in the plant.
- (r) The necessary equipment for changing programs does not have to be supplied but the contractor shall select the control system with regard to that suitable reprogramming equipment with great likelihood will be available in the purchaser's country during at least a 15 year period after the tender date.
- (s) Connection and programming of the control system shall be such that conflicts with signals from the safety and backup systems are avoided.

- (t) Hydraulic circuits in the control system shall be equipped with test connections and shall have provisions for degasing.

#### 4.10 Safety to personnel and fire protection

- (a) The plant shall be sectionalized in cells normally closed off from each other to prevent fast spreading of fire and especially of smoke. The nacelle and eventually the tower top - depending on the way of access to the rescue ladder, shall constitute at least one cell - the top cell. The tower space shall be a second cell. The foot of the tower, in case it will house electric control and switching equipment or may serve as a storage, shall be a third cell. If oil immersed power transformers are located inside the tower foot they shall be inside a fourth cell with fire resistant walls and provisions for taking care of oil leaks. Each cell shall have well located openings for venting out smoke.
- (b) The barriers between cells must be designed with regard to any needs for communication inside the tower. I.e. they must have holes, hatchways or similar to allow passing of goods using the lifting device and the passage of personnel.
- (c) Sensors of smoke or ionized air shall be installed in adequate numbers in each cell. The top cell must also have heat sensors.
- (d) There shall be a fire extinguishing equipment of the halon type for the top cell with adequate capacity to fill up and maintain the required concentration of extinguishing medium for a sufficient time in areas of high fire risk and with regard to ventilation effects.

- (e) A ladder arrangement - a rescue ladder - with a rail for safety belts is required on the outside of the tower between a level just above normal reach from the ground up to a door leading into the top fire cell. It shall be possible to open the door from both inside and outside.
- (f) The nacelle shall have two emergency exits - well apart - for people to jump out directly into the open air. It shall be possible to open the exits from both sides. There shall also be a defined way leading from the nacelle to the rescue ladder and which will be safe to use in case of smoke filled tower and tower foot.
- (g) It shall be possible to attach safety belts and rescue equipment at every emergency exit from the top fire cell and at strategic places on the outside of the nacelle and hub to be used during erection and maintenance.
- (h) The nacelle shall be permanently equipped with 5 sets of rescue belts with accessories that will allow 5 people both to jump out independently through any of the emergency exits and to climb down the rescue ladder.

In addition there shall also be sets of safety belts and accessories to allow 2 people to work outside the nacelle on platforms, on the roof and on the hub with safety against falling and to work in the sling basket with safety against falling out and against following the basket to the ground in case of lifting equipment failure.

- (i) The plant shall have 5 emergency lights of rechargable type installed on special brackets

in the nacelle, the tower and the tower foot and which can be used both as part of a permanently installed emergency lighting system and as portable units.

- (j) There shall be 2 emergency stop buttons at ground level, 2 in the nacelle and an emergency pull wire all along and within reach from the ladders in the tower.
- (k) The safety and fire protection arrangements shall be approved by local and national authorities.

#### 4.11 Erection and maintenance

- (a) It shall be possible to erect commission, and maintain the windpower plant in any season of the year with exception for casting of large volumes of concrete and painting.
- (b) It is preferred that all components of the WTS can technically be erected and dismantled independent of rain and windspeeds up to 12 m/s (10 min average) at hubheight. Erection and dismantling of heavy components will not have to take place in snowfall. Safe windspeeds for erection shall be stated.
- (c) Lubrication, inspection or other maintenance work that will require difficult climbing or crawling inside the hub or blades shall not be required more often than once per year, and are to be included in the total amount of indicated available manhours.



Inspection and maintenance requiring the use of the sling basket (see 4.6 (d)) - shall not be required every year.

- (d) A program for inspection of cracks - including cracks and delaminations in plastic materials - shall be given.
- (e) One set of all necessary tools for maintenance - except ordinary handtools - shall be part of the delivery including a basket for carrying two men during blade and tower inspection.
- (f) One set of all lifting devices (not a mobile crane however) for handling all heavy components in connection with repairs (e.g. blades, hub, shaft, gearbox, generator) shall be provided, and shall be suitably surface treated for outdoor storage. If these devices have been used for erection they shall be touch-up painted.
- (g) A description for mounting and dismantling typical heavy components and springs, links and rods in the turbine control mechanism shall be provided with estimates of the total number of man hours required for each operation. Refer to CASES OF MAINTENANCE AND REPAIR.

## 5. Loads and vibrations

### 5.1 General

All the applicable LOAD CASES described elsewhere shall be considered. With some exceptions - stated - the windpower plant shall be able to endure all of them. In the special cases a description of the consequences shall be given and an estimated probability of occurrence for the event during 50 years of operation.

Wind turbine systems are designed differently. The LOAD CASES may therefore not be representative for the critical loads of all windpower plants. For this reason compliance with the LOAD CASES or any combination thereof does not in any way limit the contractors obligation to supply a plant that is well functioning and basically and intrinsically safe.

### 5.2 Factors of safety and service life

Structural components must possess a satisfactory safety against ultimate failure, which can be achieved by applying appropriate safety factors. Swedish design codes normally only specify allowable stresses. For steel and aluminium structures these stresses imply safety factors of 1.5 for normal loads and 1.3 for exceptional loads. Where available design codes are not applicable it must be shown that the safety factors chosen result in a structure with correspondingly low probability of failure.

The probability for a failure of a primary structural component due to fatigue damage shall be extreme

ly low (order of magnitude  $10^{-5}$ ) during the service life.

### 5.3 Application of LOAD CASES

- (a) Loads due to wind, gravity, electrical connections and disconnections and various faults shall be consistently applied to the wind power plant using the assumptions specified in the LOAD CASES and considering the effects on all parts of the plant.
- (b) Dynamic loads due to inertial forces shall be included.
- (c) Loads during erection must be considered as having occurred before application of the LOAD CASES.
- (d) Fatigue calculations shall be done in three steps; first considering all normal deterministic loads together and second considering both all normal deterministic and stochastic loads together and third considering the effects of normal rare loads together with the previously mentioned.
- (e) Exceptional loads shall be studied in two steps; first considering each exceptional load separately, and second considering the effect on total fatigue life if each exceptional load is added separately to the sum of all the normal loads. The most unfavourable combination of loads and parking positions shall be discussed with the purchaser.

- (f) The effect of introducing in the strength and fatigue calculations one and two cracks in sensitive sections shall be studied. The cracks shall be the longest and widest with the most difficult shape that may pass undiscovered at an inspection using a standard crack detection method specified by the tenderer in the crack inspection program.
- (g) Not only stress but also deformations must be considered in the effects of the LOAD CASES.
- (h) Normal loads are CASES 1-10 except CASE 9 which is "normal rare".
- (i) Exceptional loads are CASES 11-25.

#### 5.4 Loads during transport and erection

Loads during transport and erection must be considered. An account shall be given for these loads.

#### 5.5 Stability, vibrations and noise

##### (a) Static and dynamic stability

- (1) At all modes of operation - including aerodynamic braking - or ways of parking, and at applicable extreme windspeeds the wind turbine shall be safe from any effects of divergence, critical flutter and stall flutter.
- (2) The critical panel flutter speed of stationary shell or component - e.g. forming part of the nacelle - shall be above  $U_{E1}$ .

- (3) The combined wind turbine-, nacelle-, machinery-tower unit must be statically and dynamically stable up to the applicable extreme windspeed for each mode of operation or way of parking whether holding by brakes or locking.
  - (4) A safety factor of at least 1.5 regarding turn-over of the windpower plant on its foundation shall be applied except in load CASE 13 A and B.
  - (5) Tower vortex shedding shall be considered.
- (b) Vibrations and noise
- (1) The level of vibrations - also of low frequency - in the nacelle and the top of the tower shall be acceptable for short stays during operation of the windpower plant in the entire operating range, up to  $U_{E4}$ .
  - (2) The level of machine noise in the nacelle and the top of the tower shall be acceptable for short stays during operation of the windpower plant in the entire operating range, up to  $U_{E4}$  using available personal protection devices.
  - (3) External noise emanating from the windpower plant shall not be above the permitted level in local and national noise regulations. For lowfrequency noise outside normal ranges extrapolated values may be used. The extrapolation shall be linear with regard to the logarithm of the frequency.

## 6. CASES OF MAINTENANCE AND REPAIR

For each case the work shall be described and the amount of labour (man-days) and hired lifting and transport capacity (types, machine-days, truck-days) shall be specified as well as the estimated shut down time. The conditions for labour have been stated elsewhere. Only exceptionally will it be possible to have a repair and maintenance crew of less than 3 men - two working up in the nacelle and on the turbine, one working at ground level and in the lower portions of the tower. Only whole man-days and equipment-days shall be counted. For the cases of maintenance also the estimated time intervals shall be stated.

### 6.1 CASES OF MAINTENANCE

- CASE M1 Exchange of all link bearings and other sliding or rolling surfaces in the turbine control mechanism (servomotors and main bearings for blade, tip, aileron or spoiler excluded).
- CASE M2 Exchange of the end stops for the teetering motion of a teetering hub turbine.
- CASE M3 Exchange of the friction pads of the turbine brake.
- CASE M4 Exchange of all oil in the gearbox lubrication system.
- CASE M5 Total annual work for lubricating all grease requiring lubrication points. Collection and disposal of old grease shall be considered.
- CASE M6 Repainting of all painted steel surfaces of the foot, the tower, the nacelle, the hub and the

turbine that are directly exposed to the outer air. 10 % of each surface is assumed to require complete thorough repainting. For the foot and the tower - if painted - the work shall be finished with a top layer covering the whole structure to achieve a pleasing uniform appearance.

CASE M7 Suggested inspection program for turbine blades to find cracks and delaminations and to check surface finish.

CASE M8 Suggested crack inspection program for the total windpower plant except the turbine blades.

## 6.2 CASES OF REPAIR

CASE R1 Repair of an erosion or lightning damage on the shell of a turbine blade located 1 m inwards from the extreme tip. (In case of all metal blades the corresponding damage could be due corrosion, erosion of paint or a bullet hole).

CASE R2 Exchange of the main bearing or bearings for a pitchable turbine blade; alternatively for the moveable blade part (tip, aileron or spoiler) used for power and speed control of the turbine.

CASE R3 Repair of a crack, just beyond the acceptable size, in the most highly stressed section of the turbine hub.

CASE R4 Exchange of all the main servomotors for the turbine control system. (Not applicable to yaw regulated turbines).

- CASE R5 Exchange of the teetering bearings for a teetering hub.
- CASE R6 Exchange of the main radial bearing of the primary shaft.
- CASE R7 Exchange of all the bearings pertaining to the first high torque step of the main gearbox. Including any such planetary wheel bearings.
- CASE R8 Exchange of gearbox.
- CASE R9 Exchange of bearings for any rod or tube passing through a central bore in the generator and/or the gear train.
- CASE R10 Exchange of the main power cables between the nacelle and the foot of the tower.
- CASE R11 Exchange of yaw bearing for the nacelle.
- CASE R12 Exchange of a yaw drive unit.



## 7. LOAD CASES

These load cases shall be the basis for the strength and fatigue calculations to be submitted to the purchaser. The plant shall - in calculations - be able to endure these load cases separately and in combinations as described elsewhere. However the load cases are only examples of loads and even if a windpower plant can be proved to endure the load cases this does not relieve the contractor from his obligation to supply a well functioning and safe plant.

Some of the load cases will allow destruction of the plant or part thereof. In these cases the probability of the load case and the consequences should be calculated and described.

### 7.1

(NORMAL) CASE 1 Function in steady winds. (Deterministic)

- (a) The 10 minute mean wind is distributed in wind-speed classes and over various sectors and with velocity profile and sharp gradient windshear as described in section 2.1 (a) "Macrometeorological winds normal conditions". Higher windspeeds than  $U_{E3}$  do not have to be considered. The wind turbine rotation or non-rotation follows the operation program.
- (b) The steady state and periodic aerodynamic loads shall be calculated in the middle of representative wind intervals in the full range up to  $U_{E3}$ . Wind shear and tower shadow shall be considered. The aerodynamic loads shall combined with gravity loads, centrifugal loads, coriolis loads, and eventual periodic loads from interaction with the electric network.

- (c) For each wind velocity interval the proper number of hours in each sector shall be applied based on a hypothetical plant availability of 100 %.
- (d) Occurrence: continuous duty, during life time.

## 7.2

(NORMAL) CASE 2 Function in turbulent wind. (Stochastic loads)

- (a) The wind is turbulent as described in section 2.1 (d) "Micrometeorological wind velocity - normal conditions". Higher windspeeds than  $U_{E3}$  do not have to be considered. It must be taken into account that the turbulence is different in the various sectors of direction and that it will be different at various heights over the swept surface due to boundary layers induced by changes in ground roughness.
- (b) The aerodynamic loads from the turbulence and the turbulence induced inertia loads (gyroscopic and coriolis, swaying and vibrations) plus loads from starting, stopping, eventual speed changing, connection to and disconnection from network shall all be added to the deterministic loads of CASE 1.
- (c) Same as in CASE 1.
- (d) Occurrence: Continuous duty during life time.

## 7.3

(NORMAL) CASE 3 Common system fault. (Deterministic)

- (a) The wind velocity is steady at rated speed. The turbine is producing power for the network.

- (b) A fault occurs suddenly and will initiate a fully controlled stop procedure. The fault is not of a type that interferes with the function of the control system.
- (c) The load shall be considered separately for stability and strength and together with other normal loads for fatigue.
- (d) Occurrence: 5 times during the commissioning period and thereafter once per month, during life time.

## 7.4

(NORMAL) CASE 4 Blade control fault at high windspeed.  
(Deterministic)

- (a) The wind velocity is steady and the highest at which the unit is intended to produce any power is just below the high cut-out windspeed. The turbine is producing power for the network.
- (b) The turbine control is instantaneously, although limited by any inherent maximum operation rate, set in that position which will produce maximum axial aerodynamic pressure on the turbine. N.B. any back-up protection system, e.g. generator overload, and emergency stop procedure are fully operational.
- (c) The load shall be considered separately for stability and strength and together with other normal loads for fatigue.
- (d) Occurrence: Once at commissioning and thereafter every second year during life time.

## 7.5

(NORMAL) CASE 5 Blade control fault at rated windspeed.  
(Deterministic)

- (a) The wind velocity is steady at rated speed. The turbine is producing power for the network.
- (b) The turbine control is instantaneously, although limited by any inherent maximum operation rate, set at that position which will produce maximum aerodynamic braking effect. N.B. any back-up protection system, e g reverse power or overcurrent, and emergency stop procedure are fully operational.
- (c) The load shall be considered separately for stability and strength and together with other normal loads for fatigue.
- (d) Occurrence: Once at commissioning and there after every second year during life time.

## 7.6

(NORMAL) CASE 6 Overspeed. (Deterministic)

- (a) The wind velocity and the state of blade control is in that normal combination which would give the highest steady state run-away speed.
- (b) Sudden loss of connection to the network leading to loss of torque reaction and simultaneously to loss of local AC supply. The back-up protection system is operational.
- (c) The load shall be considered separately for stability and strength and together with other normal loads for fatigue.

- (d) Occurrence: 4 times per year.

## 7.7

(NORMAL) CASE 7 Sudden shortcircuit on line outside the main circuit braker. (Deterministic)

- (a) The turbine is producing rated power at the maximum intended windspeed for such duty. The wind is steady.
- (b) There is a sudden shortcircuit on the line just outside the main circuitbraker. The shortcircuit is to be regarded as 2 phase for power circuits but as 3 phase for mechanical components. The local AC supply disappears simultaneously. The protection or back-up protection system is functioning as planned for such an event.
- (c) The load shall be considered separately for stability and strength and together with other normal loads for fatigue.
- (d) Occurrence: Once per year.

## 7.8

(NORMAL RARE) CASE 8 Sudden shortcircuit on line outside the main curcuit breaker with returning voltage. (Deterministic)

- (a) The turbine is producing rated power at the maximum intended windspeed for such duty. The wind is steady.
- (b) There is a sudden 3 phase shortcircuit on the line just outside the main circuitbreaker. The short circuit is cleared immediately before the control and protection system has had time to

operate and full line voltage returns before the magnetic field in the generator has been affected but  $180^{\circ}$  el out of phase with the existing field creating maximum torque.

Local AC supply is only momentarily affected by the short voltage disappearance.

- (c) The load shall be considered separately for stability and strength and together with other normal loads for fatigue.
- (d) Occurrence: For the generator this may be considered as an extreme case which will happen only once in the life time. For the rest of the windpower plant this case is assumed to happen once at comissioning, once after 10 years and once after 20 years.

## 7.9

### (NORMAL) CASE 9 Ice loads in operation (Deterministic)

- (a) The turbine is producing rated power at the maximum intended windspeed for such duty. The wind is steady.

Leading edge ice build-up, as follows:

- (i) Total amount of ice on each blade  

$$= 0,1 \cdot \lambda^2 \cdot R \text{ kg}$$

( $\lambda$  is the ratio tip speed/rated windspeed)

(ii) Ice distribution along each blade as function of radius =

$$= 0,3 \cdot \frac{\lambda^2}{R^2} \cdot r^2 \text{ kg/m}$$

(iii) Ice building up symmetrically on all blades.

(b) Sudden loss of ice deposit on one blade. The radial unbalance load lasts for the time that is needed for the protection system to react and to bring the windpower plant into a safe mode.

(c) The load case shall be considered separately for stability and strength and together with other normal loads for fatigue.

(d) Occurrence: Three times per year. If the windpower plant has ice detector systems with a high proven reliability the assumed occurrence will be only once in every three year period.

Note: There is considerable uncertainty about how ice forms on a blade, how it sticks to the surface and how it breaks of. Until more experience is gained the above formulas will be used.

#### 7.10

(NORMAL) CASE 10 Starting with ice load. (Deterministic)

(a) The turbine is in "stand by" mode. 50 mm ice is covering all mechanisms out in the open air and 20 mm ice is covering one side of each blade over all movable joints including joints between blade root and hub.

- (b) The wind increases over cut-in speed and starting attempts are made. Any ice breakage is assumed to be in small pieces not causing large unbalance.
- (c) The load case shall be considered separately for strength and together with other normal loads for fatigue.

The case may be of special importance for specific parts of the windpower plant.

- (d) Occurrence: Three times per year. If the wind power plant has ice detector systems with a high proven reliability the assumed occurrence will be only once in every three years.

#### 7.11

(EXCEPTIONAL) CASE 11 Sudden shortcircuit in the windpower plant

- (a) The turbine is producing rated power at the maximum intended windspeed for such duty. The wind is steady.
- (b) There is a sudden threephase shortcircuit at the top end of the main power cabling between generator and tower foot. The control and protection system is functionable. The local AC supply will be disturbed by any reduction in voltage level.
- (c) The load shall be considered separately but an account shall also be given for how such faults may affect the remaining life of the plant.



## 7.12

(EXCEPTIONAL) CASE 12 Extreme gale wind loads. Symmetric short gust

- (a) The average windspeed is  $U_{E3}$ . The windpower plant is in that mode and/or position, free, held by brakes or locked, which is recommended by the manufacturer for situations when very high winds are expected.

There is no local AC power available.

- (b) The plant is hit by a sudden gust of  $U_{E1}$  in the main wind direction during 3 seconds.
- (c) The wind may be axial or from the side.

The most unfavourable combination of wind direction, aerodynamic load and gravity shall be considered for various parts of the plant. Tilting, twisting the plant or turning the turbine.  $C_L$  max and  $C_D$  max shall be used for chordwise and flatwise relative wind directions.  $C_L$  max will act on whole blade surfaces and  $C_D$  max on blade surfaces projected on a plane perpendicular to the wind direction. NB the most unfavourable combinations of loads may be different for different parts of the plant.

Due to the short instantaneously applied gust mechanical dynamic effects must be considered.

## 7.13

(EXCEPTIONAL) CASE 13 Extreme gale wind loads. Symmetric long gust

- (a) Same as CASE 12.

- (b) The windpower plant is hit by a sudden gust of  $U_{E2}$  during 1 minute.
- (c) Same as CASE 12. However due to the long duration of the gust special attention may have to be given to vibrations and heating of any slipping brakes.

## 7.14

(EXCEPTIONAL) CASE 14 Extreme gale wind loads. Unsymmetric short gust

- (a) The case is almost identical to CASE 12 with the only difference that the gust hits only the most unfavourably positioned blade.

## 7.15

(EXCEPTIONAL) CASE 15 Extreme gale wind loads on windpower plant with critical fault. Symmetric short gust.

- (a) The average windspeed is  $U_{E3}$ .

The windpower plant has a critical fault and is locked in the following alternative ways. Each alternative must be studied.

- (1) The turbine rotation is locked in the most unfavourable position. All other movements as prescribed by the manufacturer.
- (2) The jaw rotation is locked in the most unfavourable position. All other movements as prescribed by the manufacturer.
- (3) Both turbine and jaw rotation are locked in the most unfavourable positions. All other movements as prescribed by the manufacturer.

- (b) The plant is hit by a sudden wind gust of  $U_{E2}$  during 3 seconds.
- (c) The wind may be axial or from the side.

The most unfavourable combination of wind direction, aerodynamic load and gravity shall be considered for various parts of the plant. Tilting, twisting the plant or turning the turbine.  $C_L$  max and  $C_D$  max shall be used for chordwise and flatwise relative wind directions.  $C_L$  max will act on whole blade surfaces and  $C_D$  max on blade surfaces projected on a plane perpendicular to the wind direction. NB the most unfavourable combinations of loads may be different for different parts of the plant.

Due to the short instantaneously applied gust mechanical dynamic effects must be considered.

#### 7.16

(EXCEPTIONAL) CASE 16 Extreme gale wind loads on wind power plant with critical fault. Unsymmetric short gust.

- (a) The case is almost identical to CASE 15 with the only difference that the gust hits only the most unfavourably positioned blade.

#### 7.17

(EXCEPTIONAL) CASE 17 Ice loads on windpower plant with extreme gale winds.

- (a) The average windspeed is  $U_{E3}$ . The windpower plant is in that mode and/or position, free, held by brakes or locked, which is recommended

by the manufacturer for situations when high winds are expected.

Local AC power is available.

All turbine blades are covered on one side by a 50 mm layer of ice. Also all movable joints on the blades and between blades and hub are covered on one side. Mechanisms out in the open air are covered by a 100 mm ice layer. Ice density is  $900 \text{ kg/m}^3$ .

- (b) The plant is hit by a sudden windgust of  $U_{E2}$  during 3 seconds.
- (c) Same as (c) in CASE 12. However the maximum lift  $C_L$  max is never higher than 0,8 due to profile distortion.

#### 7.20

(EXCEPTIONAL) CASE 20 Bird collision with wind turbine blades.

- (a) Normal operation at a windspeed  $U$  just below the highest cut out speed.
- (b) The blade is hit by a bird at any place between 0,7 and 1,0 of the blade length from the hub at or near the leading edge. The bird velocity is  $U+15 \text{ m/s}$  and the bird weight is 1 alternatively 4 kgs.
- (c) Bird impacts of 1 kg and less may not cause any damage at all to the blade. Bird impacts of 4 kg and less may not cause damage to the load carrying structure of the blade or cause sizeable parts to be thrown off.

## 7.21

(EXCEPTIONAL) CASE 21 Rifle shots.

Blade resistance to rifle shots shall be described. A hit by a bullet from a common type of hunting rifle (for moose) in the - relatively seen - most highly stressed section of the load carrying beam of the blade must not cause any damage that can initiate propagating cracks when normal load cases are applied afterwards. It is considered unlikely that a bullet will hit bearings, control mechanisms, welds or joints.

## 7.22

(EXCEPTIONAL) CASE 22 Loss of control of one blade at rated wind velocity.

- (a) The wind velocity is steady at rated speed. The turbine is producing power for the network.
- (b) Instantaneously control of one blade is completely lost.
- (c) The behaviour of the powerplant shall be described. The plant shall endure the loads that will occur.

N.B. This load case is not applicable where a mechanical link mechanism between blades exists and can be proved to have such high reliability that the blades will always be coupled under all conditions and that control will never be lost of one blade only.

## 7.23

## (EXCEPTIONAL) CASE 23 Loss of a whole blade.

- (a) The wind velocity and the state of blade control is in that normal combination which would give the highest steady state run-away speed.
- (b) For some reason the wind turbine starts to run-away. Just before it reaches that speed where the back-up overspeed protection initiates a shut down a whole blade breaks off suddenly at the root.
- (c) All forces on and behaviour of the remaining structure shall be calculated for that initial position of the failing blade which will give the maximum effect on the nacelle and tower.
- (d) Length of throw shall be calculated for that initial position of the failing blade which gives the maximum throw distance.
- (e) Length of throw and forces on and behaviour of the remaining structure shall also be studied for the case that the blade breaks off when it is in the "most likely failure state". Here air breaking may have already started and the blade is in that azimuth and airbreak state where the combined effects of aerodynamic, centrifugal and gravity forces produce the highest stress in a critical point of the blade root.
- (f) The plant may fall and may be damaged completely beyond repair. No blade piece must however fall outside a radius of 250 m including a theoretical slide on the ground and no part of the nacelle and tower must fall outside a radius of

1.5 x hubheight. It is an advantage if the foundation and most of the tower foot is intact for reuse.

- (g) The foreseeable theoretical effects of the load case must be described and the probability of occurrence during a 30 year period must be estimated. The best available methods of calculation and estimation shall be used. If the foundation and lower part of tower foot is damaged beyond reuse (e g due to overstressed reinforcement) an estimation of the work and cost for removal of these damaged structures and for construction of a new foundation must be presented.

#### 7.24

(EXCEPTIONAL) CASE 24 Loss of a blade section.

- (a) Same as in CASE 23.
- (b) Same as in CASE 23 but instead of losing a whole blade there is a loss of a movable tip or aileron or if the whole blade is pitchable or spoiler controlled loss of either half of the blade or the outer part from the most highly stressed section which ever is the shortest.
- (c) Same as CASE 23.
- (d) Same as CASE 23.
- (e) Same as CASE 23.
- (f) The main structure of the plant shall be intact. No machinery must be torn loose inside the nacelle. After having changed the failing blade and certain over stressed components - to be

specified by the manufacturer - the plant shall be ready for reuse.

- (g) The foreseeable theoretical effects of the load case must be described. The probability of occurrence during a 30 year period and the effect on the remaining fatigue life of the plant must be estimated. The best available methods of calculation and estimation shall be used.

(EXCEPTIONAL) CASE 25 Lightning strike.

This load case need not be combined with any other than normal load at rated steady windspeed.

The theoretical effects of "unusually" and "exceptionally" strong or weak strikes shall be estimated and described. The estimated number of "unusual" strikes of both kinds that the plant will endure shall be stated.



IEA LS WECS MEETING, STRUCTURAL DESIGN CRITERIA, MARCH 1983Rotor Blade Loads on Horizontal and Vertical Axis Wind TurbinesJ. Holt and D.J. Milborrow

Central Electricity Generating Board  
Central Electricity Research Laboratories  
Kelvin Avenue  
Leatherhead  
Surrey KT22 7SE

SYNOPSIS

Strain gauge measurements have been made on the blade spars of a 1.7 m diameter horizontal axis wind turbine and a 6 m diameter vertical axis machine. Both sets of measurements clearly show the aerodynamic and mechanical loads. As anticipated, edgewise gravitational bending loads predominate with the horizontal axis machine and these are readily predictable. Fluctuating components in the flapwise load can also be identified due to a number of sources, both mechanical and aerodynamic.

An analysis of the measured flapwise strains shows that those due to gravitational bending, centrifugal bending (both present due to coning of the rotor) and quasi-steady-state aerodynamic thrust can be clearly identified and are in agreement with predicted values. Fluctuations due to gusts, wind shear, wind yaw and rotor tilt are more difficult to identify and separate but are, in general, lower than predicted by steady state analyses.

A statistical analysis (see Appendix) has been used to correlate the higher frequency variations in load with corresponding windspeed fluctuations. This shows that the form of the quasi-steady-state relationship is preserved but with an effective 50% decrease in the ratio of generated aerodynamic load to windspeed.

Occasional high amplitude fluctuations were also measured, which did not appear to be associated with wind gusts. These are believed to be due to a combination of mechanical and aerodynamic forces associated with yawing of the rotor.

The measured and predicted loads for the horizontal axis machine are summarized in Table 1.

The fluctuating flapwise bending loads incurred by a vertical axis blade, have also clearly identified; these are of sinusoidal form with a marked asymmetry between upwind and downwind passes.

### Implications for Load Case Studies

It must be emphasised that these conclusions are tentative and may be specific to this particular rotor.

1. Mechanical loads predominate - particularly edgewise bending under gravity but mechanical forces in yawing motion also appear much greater than aerodynamic ones.
2. Steady state aerodynamic loads can be predicted well by the established techniques which can therefore be used to define a load spectrum.
3. Fluctuating aerodynamic loads, at frequencies greater than (rotational frequency/10) are attenuated by the rotor. A factor of 2 applies in this case, both to systematic fluctuations and random turbulence.

### APPENDIX

If the probability distribution is normal, as in figure 3, i.e. if  $N(v) dv$  is the probability that  $v$  lies in the range  $v \rightarrow v + dv$  then:

$$N(v) = A \exp - \frac{(v-v_0)^2}{2\sigma_v^2} \quad \dots (1)$$

If the distribution of wind speed, measured remote from the turbulence, leads to a corresponding normal distribution of bending moment as approximated in Figure 4 by:

$$F(BM) = C \exp - \frac{(BM)^2}{2\sigma_B^2} \quad \dots (2)$$

then, since the transformation between distributions is:  $N(v) dv = F(BM)d(BM)$  then the relationships between  $v$  and  $BM$  must be linear:

$$BM = \beta v = \frac{\sigma_B}{\sigma_v} \cdot v$$

For the results in figures 3 and 4 we then have

$$\beta = 48.8 \text{ N-s} \quad \dots (3)$$

The corresponding relationship derived from theoretical considerations ( $v < 12 \text{ m/s}$ , Figure 1) is

$$\beta = 100 \text{ N-s approx.}$$

TABLE 1

Spar Loads at 54 RPM, 8 m/s

	Estimate	Measured	Comment
<u>Flapwise (73% radius)</u>	(Fig. 1)	(Fig. 2)	
"Steady" Centrifugal bending Aerodynamic bending -5 m/s	1.1 KNm } 0.5 KNm }	1.5 KNm	Function of Construction
Aerodynamic Bending (change 5-12 m/s)	0.6 KNm	0.5 KNm	Clearly visible
Cyclic Wind shear and tilt Yaw (aerodynamic)	$\pm 130$ Nm } $\pm 100$ Nm } (at 20°)	$\pm 100$ Nm	Not easily separable
Yaw (mechanical)		$\pm 200$ Nm	Includes gyroscopic and inertia forces
<u>Edgewise (61% radius) - rotor in variable speed mode</u>			
Gravity bending	$\pm 1.6$ KNm		
Aerodynamic torque	0.4 KNm		Well correlated with wind

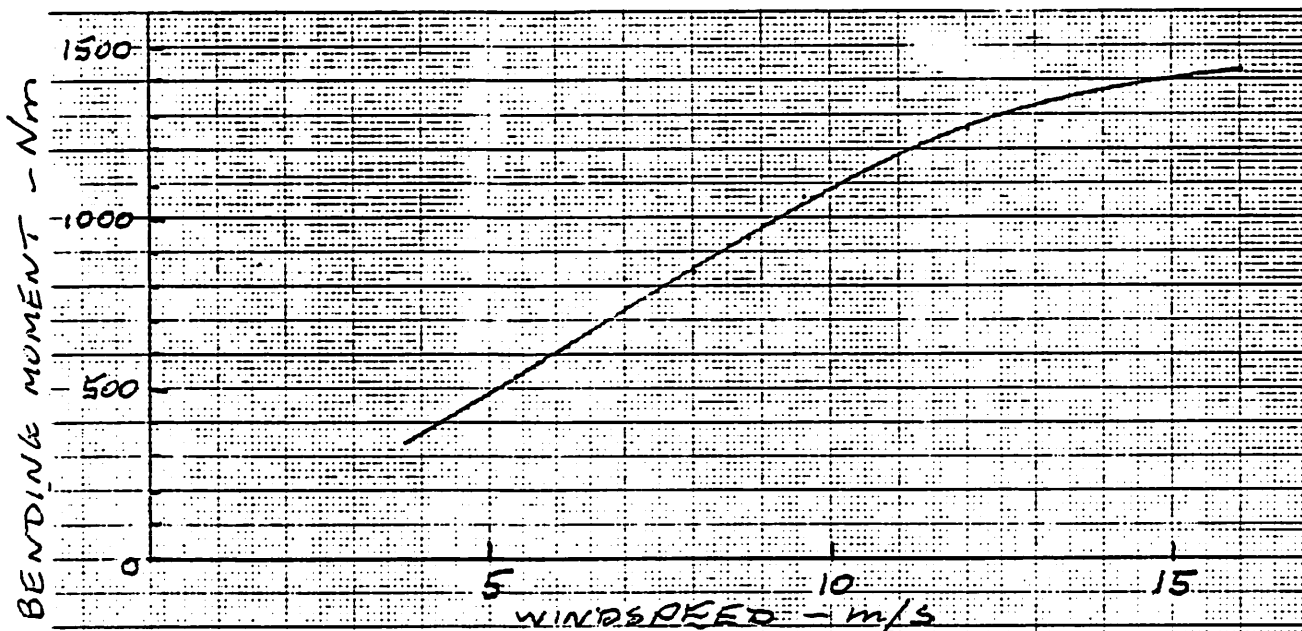
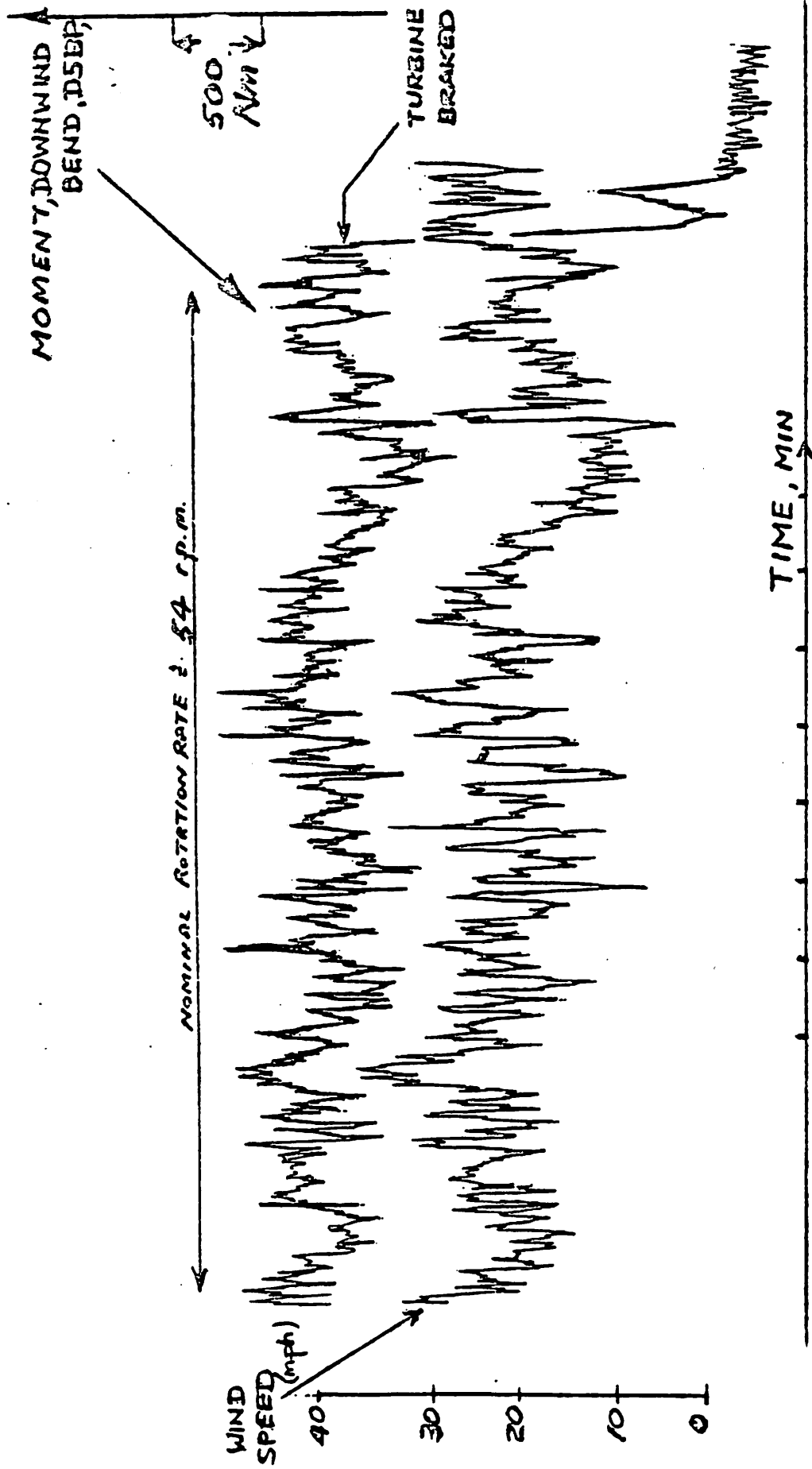
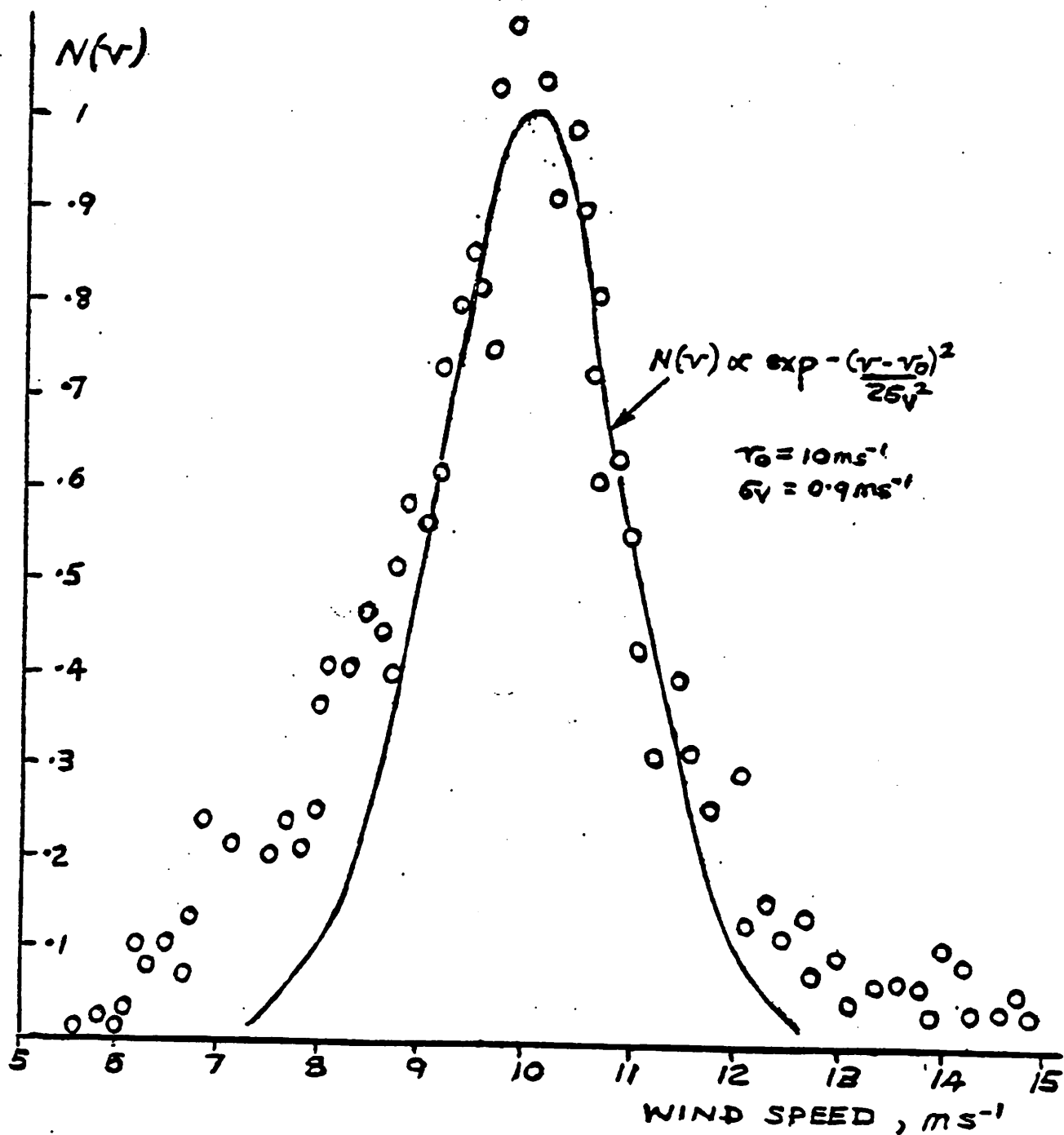

FIG 1 PREDICTED BENDING MOMENT AT 73% RADIUS  
DUE TO AERODYNAMIC LOAD



CORRELATION OF MEAN BENDING STRAIN, DSBP AND WIND SPEED

FIG 2

**FIG 3**

WIND SPEED DISTRIBUTION, 16 MIN. PERIOD DURING RUN  
AT 54 RPM

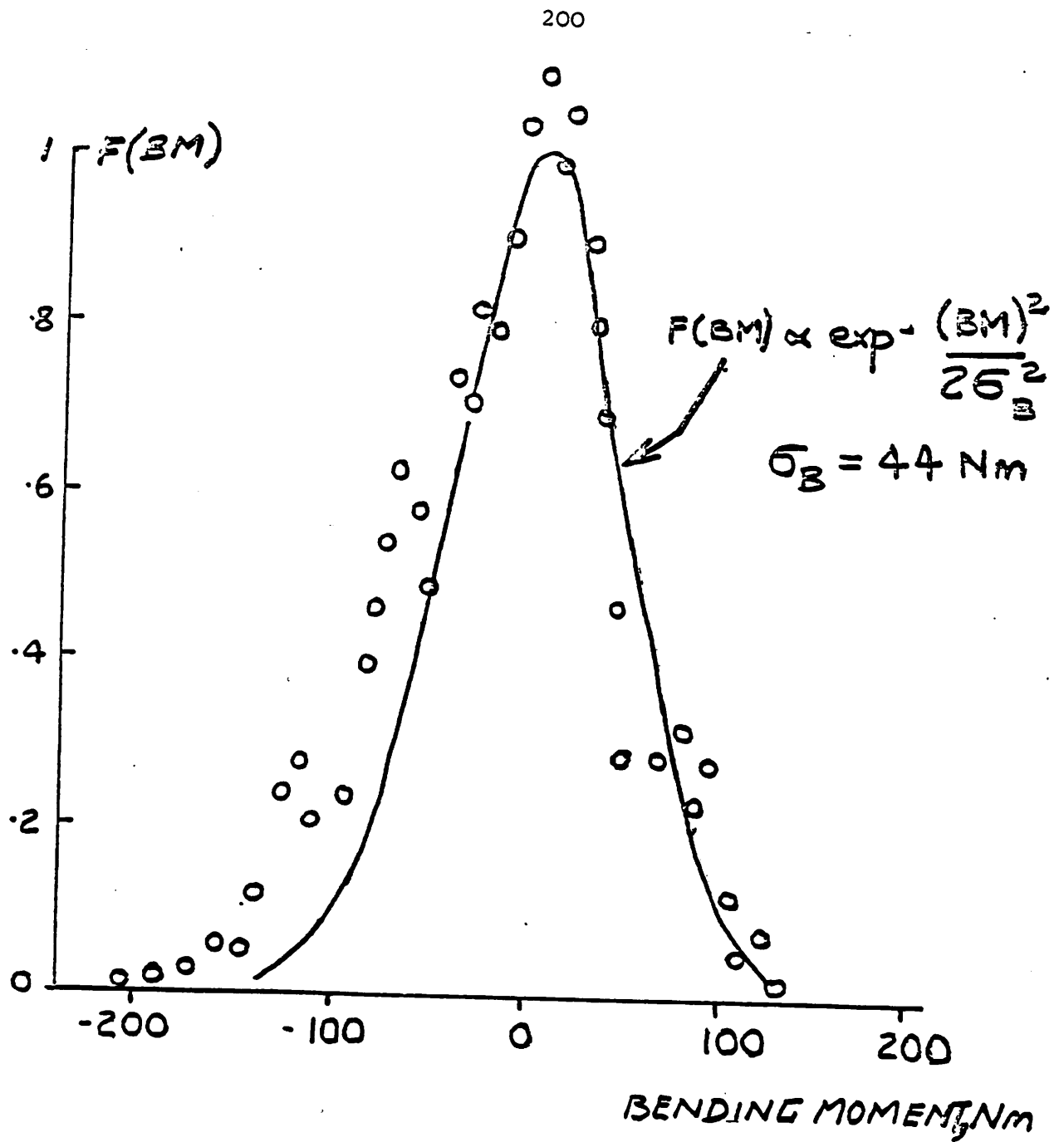

FIG 4

PROBABILITY DISTRIBUTION OF BENDING MOMENT,  
ABOUT MEAN, SAME PERIOD AS FIG 3., BRIDGE DSBP

Transmission Dynamics of Vertical Axis  
Variable Geometry Wind Turbines

I.P.Ficenec, NEI Cranes Ltd.

The contribution presents a resume of the dynamic study carried out as a part of the preliminary feasibility study for the Variable Geometry vertical Axis Wind Turbine (VGVAWT). Musgrove (Ref.1) suggested a scheme of varying the geometry of blades as a means of shedding the excess power at high wind speeds and thus extending the upper limit of the wind turbine operating range and improving the overall energy capture performance of the machine. The machine referred to in the contribution is the design/development implementation of the original concept with a 25m diameter rotor and power output in the region of one hundred kilowatt. The machine, the schematic diagram of which is shown in Fig.1 is intended to serve as a research and development prototype providing a test bed of sufficient size and flexibility to allow an investigation of various design options. The original concept of blade furling was retained in this machine although with a modification in the actual operating mechanism.

A typical arrangement of the power train of the wind turbine is shown in Fig.2. It consists of the rotor cross-arm carrying two blades by means of two drag struts and actuator struts which provide the furling action. The cross-arm is attached to the hub shaft which carries the low speed brake at its lower end. Immediately below this brake is located the first speed increasing gear box, with the output torque transmitted to the second speed increasing gear box at ground level by means of the vertical downshaft. The output shaft of the lower gear box carries the high speed brake and provides the driving torque for the generator.

The dynamic study of the transmission train was aimed at providing design backup in terms of data concerning the entire transmission train and in particular natural frequencies, forcing frequencies and the variation and magnitude of torque transmitted by various elements of the train under the selected range of inputs simulating critical design operating conditions. During the study several dynamic models for this system were developed together with their cor-

responding system differential equations. The system equations were used in several ways: to obtain system eigenvalues and eigenvectors, to obtain response characteristics for the system and to calculate the response of the system to the selected types of operational inputs. A more detailed description of the investigations is given below.

#### Selection of load cases.

A wide range of operating conditions can occur during the service life of the wind turbine, resulting in a variety of loading conditions for the transmission train. However, for the purpose of the preliminary study these were limited to the operational cases which were considered to yield the most significant loading cases and these are listed below.

- a/ Loads arising from steady operation at constant wind speed and rotor speed
- b/ Loads arising from a gust of wind of variable profile
- c/ loads arising from the application of the low speed brake.
- d/ Loads arising from the application of the high speed brake
- e/ Loads arising from the combined application of both brakes

It is one of the inherent characteristics of the vertical axis wind turbine with a discrete number of blades that even under steady operating conditions, viz. constant wind speed and constant rotor speed, the aerodynamic forces developed by the rotor blades are cyclic in nature. These cyclic forces from the individual blades are additive when transformed into moments about the rotor axis and hence the torque developed by the rotor at the hub shaft is cyclically variable, providing a potential for continuous fatigue loading of the system. Furthermore, should any of these forcing fre-



quencies lie too close to relevant natural frequencies or pass through them during start up or shut down an unacceptable situation may arise. It can be shown that the variation of torque consists of the fundamental frequency equal to  $2p$  excitation together with several higher harmonics. The exact harmonic content, in terms of number and respective magnitudes, is dependant on the operating regime of the machine and whether or not the blades are passing through a stall regime during each rotation. The aim of the study which dealt with the steady state operation was to investigate the dynamic loads in the transmission train under those conditions and provide information about the design loads present. Furthermore, the study was also used to investigate the possible ways of attenuating the basic cyclic torque through the transmission train and thus improve the fatigue life of the wind turbine but also the quality of the generator drive torque and consequently the power generated ( See fig.3 ).

In the investigation of the response of the system to a gust of wind, the wind speed was considered to be uniform across the diameter of the rotor but variable in time according to the selected velocity profile. At this stage the velocity profiles were restricted to a simple step-wise and a ramp type profile with a variable rate of rise. Typical profiles are shown in Fig.4. It was felt that this representation was adequate for the purpose at the time as it yielded all necessary information about the dynamic characteristics of the system and results could be easily interpreted to cover any other type of wind profile. Although the approach adopted, viz. modal response analysis and time history solution, could deal with any time dependant load input expressed either in analytical or numerical form, including that of random variable input, it was felt that the relatively simple input forms were preferable. They yielded all information required at the time and were much more manageable as a part of the design process. Stochastic inputs generally require much more computational effort per single investigation together with the necessity of a stochastic approach to the analysis of results. This can only be carried out provided a statistically significant number of runs is available for each operating condition. Greatly increased computational effort to achieve that was felt not justified.

Studies dealing with the low speed brake, which is a multiple caliper disc brake, concentrated on determining the system response during various braking regimes. The braking torque profile of a single caliper was assumed to be of ramp type, with a quick rise to full braking torque followed by a dwell at the maximum value. The temperature effect on the brake efficiency was neglected, although there is no difficulty in its being incorporated in the solution, e.g. to simulate brake fading. The braking action of the complete brake assembly was composed from these individual contribu-

tions and a torque diagram of typical braking sequence is shown in Fig.5. Torque profiles of individual brakes and their combinations could be varied as required in order to establish optimum sequencing and timing. The brake performance was also established together with stopping times and magnitudes of torque within the system under the selected operating regimes. Similar investigation were carried out for the lower high speed brake and for a combined operation of both brakes.

### Dynamic models

The transmission train already described, can be modelled in full as a dynamic system with fifteen degrees of freedom and a typical model of this type is shown in Fig.6. The model was restricted to linear behaviour and consequently non-linear effects such as backlash in gears and others were neglected. Although there is no difficulty in introducing these effects into the analysis, it was again felt that for the purpose of the present studies the effects were of secondary importance and hindered rather than helped the understanding of problems involved. For some studies, in particular of parametric character, the full model was sometimes unnecessarily detailed and various other simplified version were also developed to represent different salient aspects of the system dynamic behaviour. The simplest model of this type was that with only four degrees of freedom shown in Fig.7 and later used elsewhere in the model developed to investigate the system control behaviour. Depending on each particular investigation, a model was selected accordingly.

As already mentioned system equations were developed for each model and these were then used

- a/ to calculate system eigenvalues and eigenvectors
- b/ to calculate system response to various inputs by using modal response analysis
- c/ to calculate system response to various inputs by numerical integration of system equations, i.e. time history solutions

The techniques under b/ and c/ may appear to give the same answers, however each technique had its advantages and disadvantages. Modal response analysis was used mostly for parametric studies of maximum response of linear systems to analytical inputs, whilst the time history approach was used in cases where the response depended upon non-linear behaviour and non-analytical inputs.

The system eigenvalues and eigenvectors were obtained directly from the system matrices by using eigenvalue extraction techniques. The natural frequencies were compared with the forcing frequencies present and combined in diagrams such as the spoke diagram shown in Fig.8. These eigensolutions were also used in the modal response analysis described in greater detail in Appendix 1.

Typical examples of results from these investigations are shown in Fig.9 to 10.

#### References

- 
1. P.J. Musgrove : "The Variable Geometry Vertical Axis Windmill" International Symposium on Wind Energy Systems, Sept. 7-9, 1976.

Appendix 1  
-----

Assume the system to be described by the matrix equation

$$[M] \{\ddot{x}\} + [K] \{x\} = \{0\}$$

The response of this system to an input described by a column vector  $\{P\}$  is required.

Assume the system to have eigenvalues  $w_1, w_2, \dots, w_n$  and associated modal matrix  $\{x_M\}$ .

The system equations can be decoupled by using the normalized modal matrix

$$\{x_N\} = \{x_M\} [C]^{-1}$$

where  $[c]$  is the normalised mass matrix of the system. The response of the system to the given input in normal coordinates can then be calculated by using the Duhamel's integral for each mode

$$q_i(t) = (1/w_i) \int_0^t \mu(\tau) \sin w_i(t-\tau) d\tau$$

and the resultant response transformed back into the original physical coordinates and the system response obtained and analysed

$$\{x\} = \{x_M\}^T \{P\} \{x_N\} [C]^{-1}$$

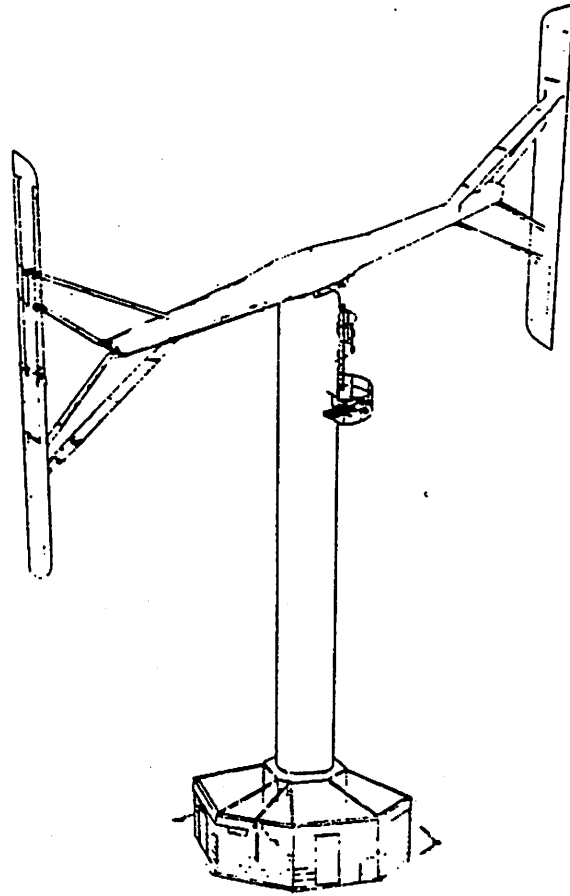

Fig.1 Schematic Diagram of the VAVG Wind Turbine

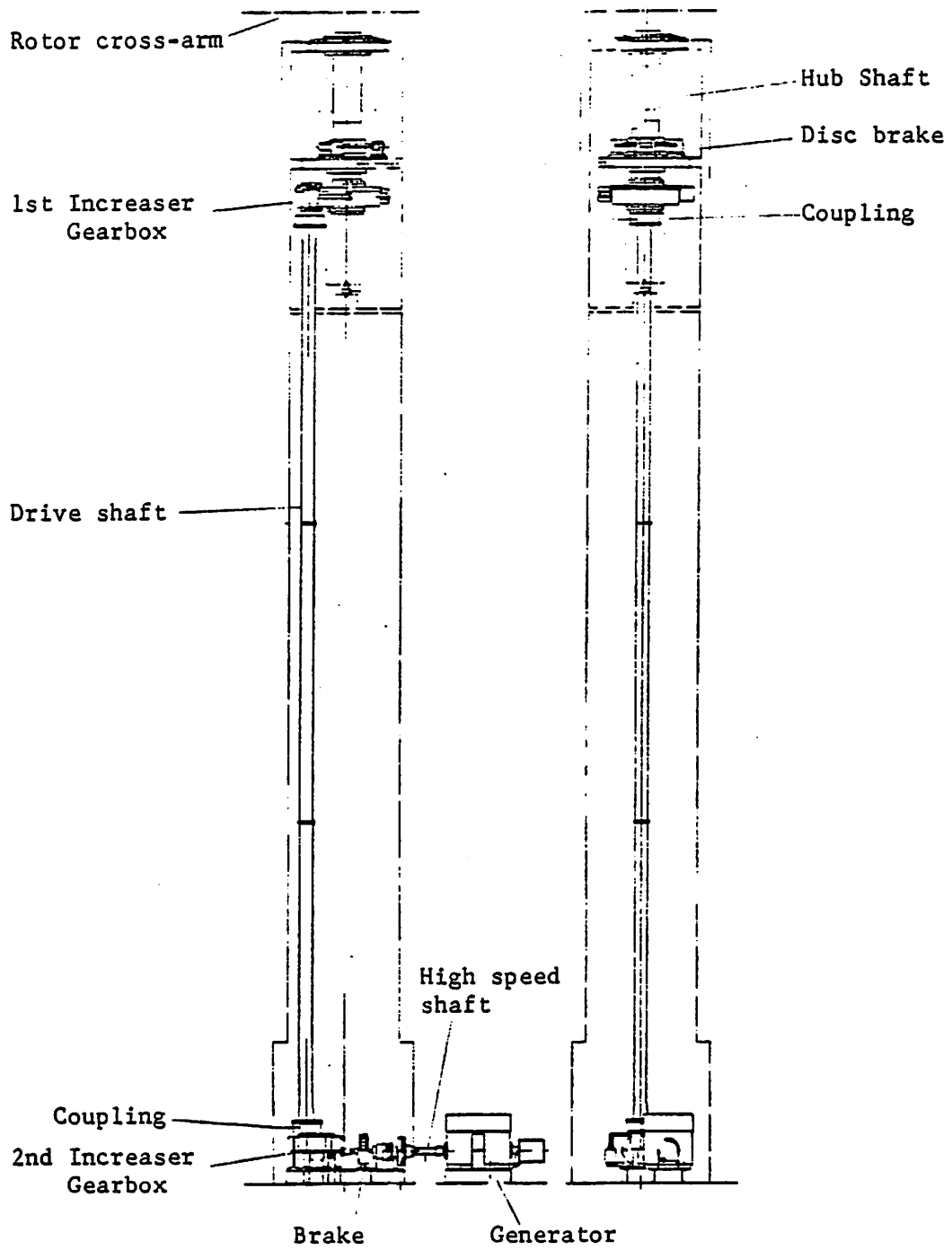

Fig.2 Schematic Diagram of Transmission Train

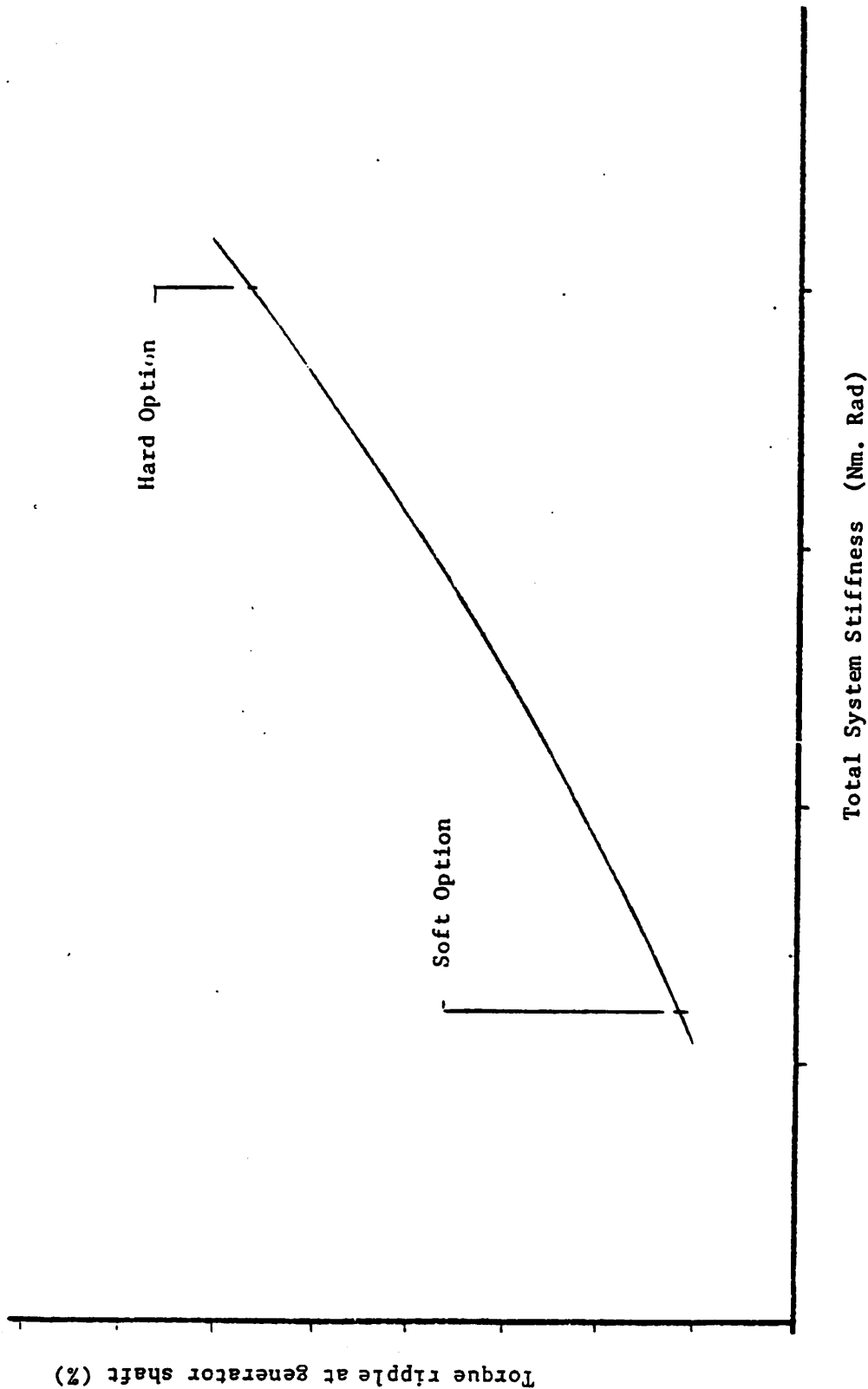
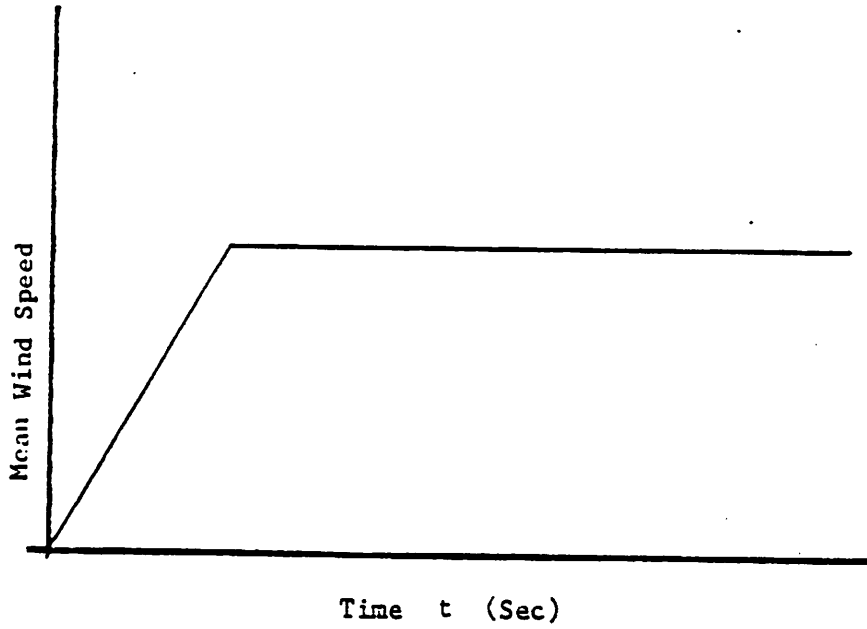
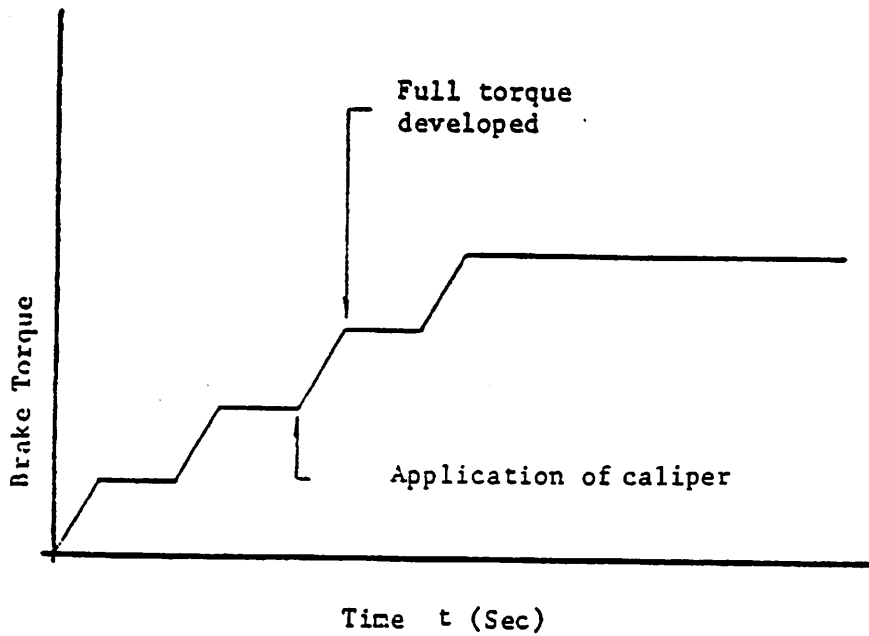

Figure 3 Variation of torque ripple against the total torsional stiffness of the system



Typical wind velocity profile

Figure 4.



Typical Brake Torque Diagram

Figure 5



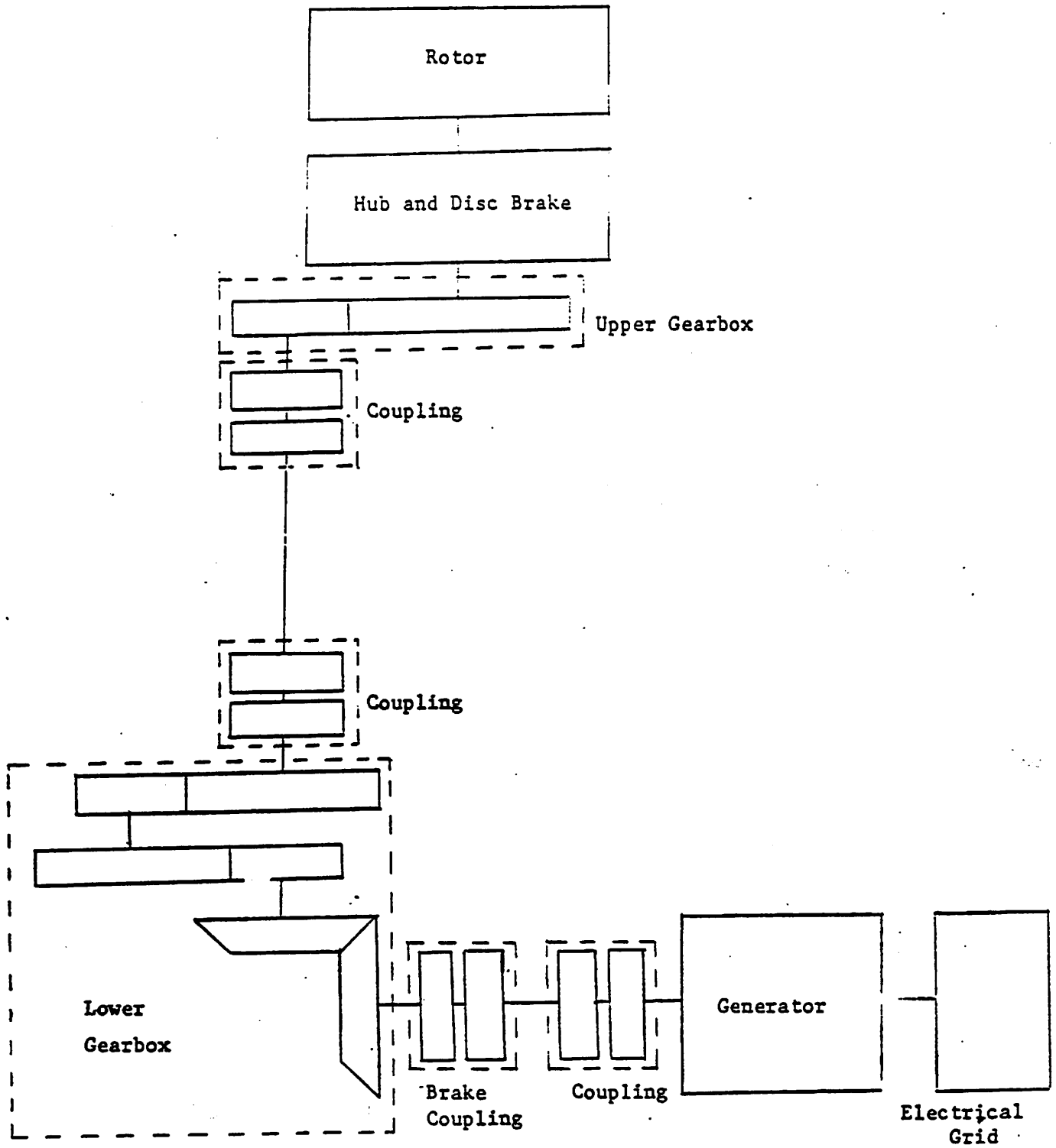

Fig.6 Schematic Diagram of a 15 D.O.F. Dynamic Model  
of Power Train

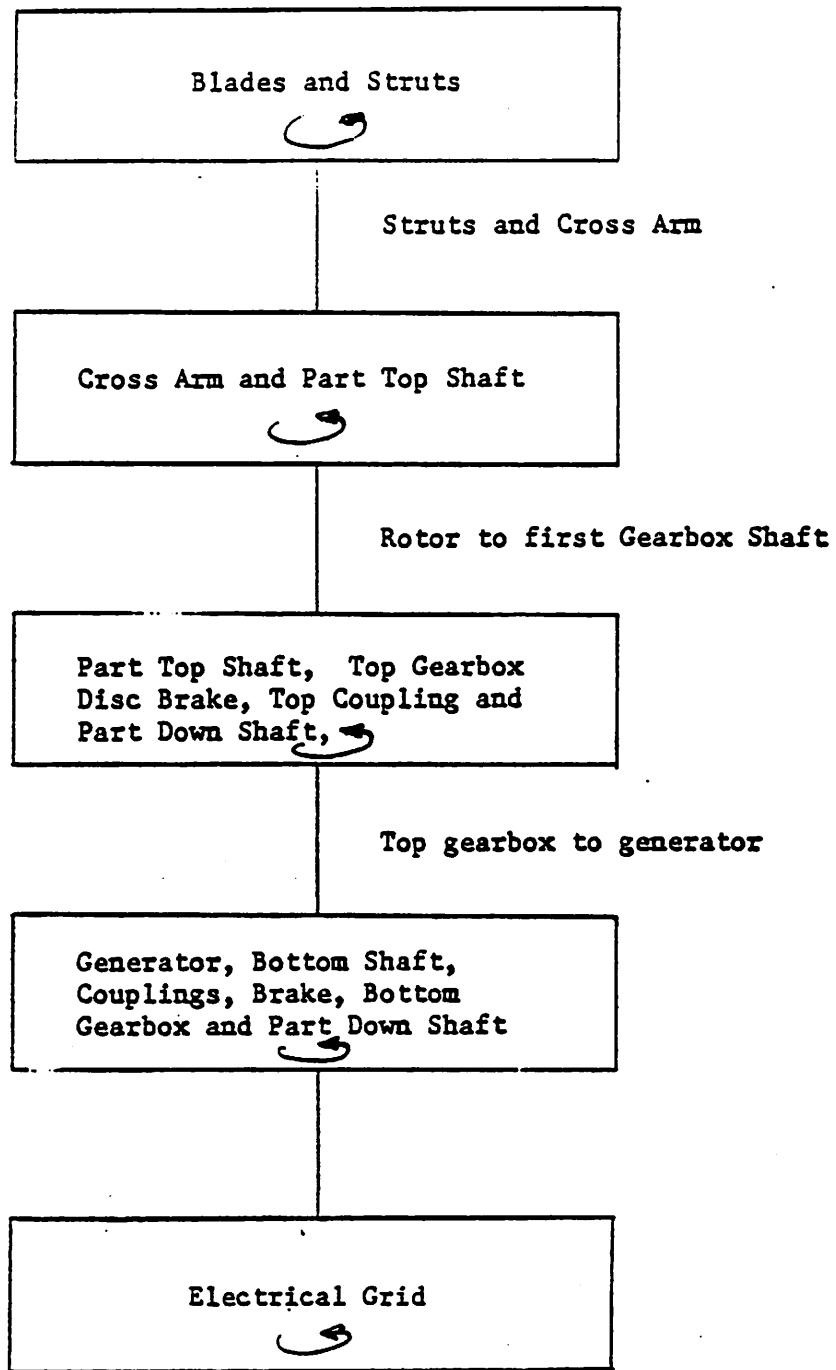

Fig.7 Schematic Diagram of a 4 D.O.F. Dynamic Model of Power Train

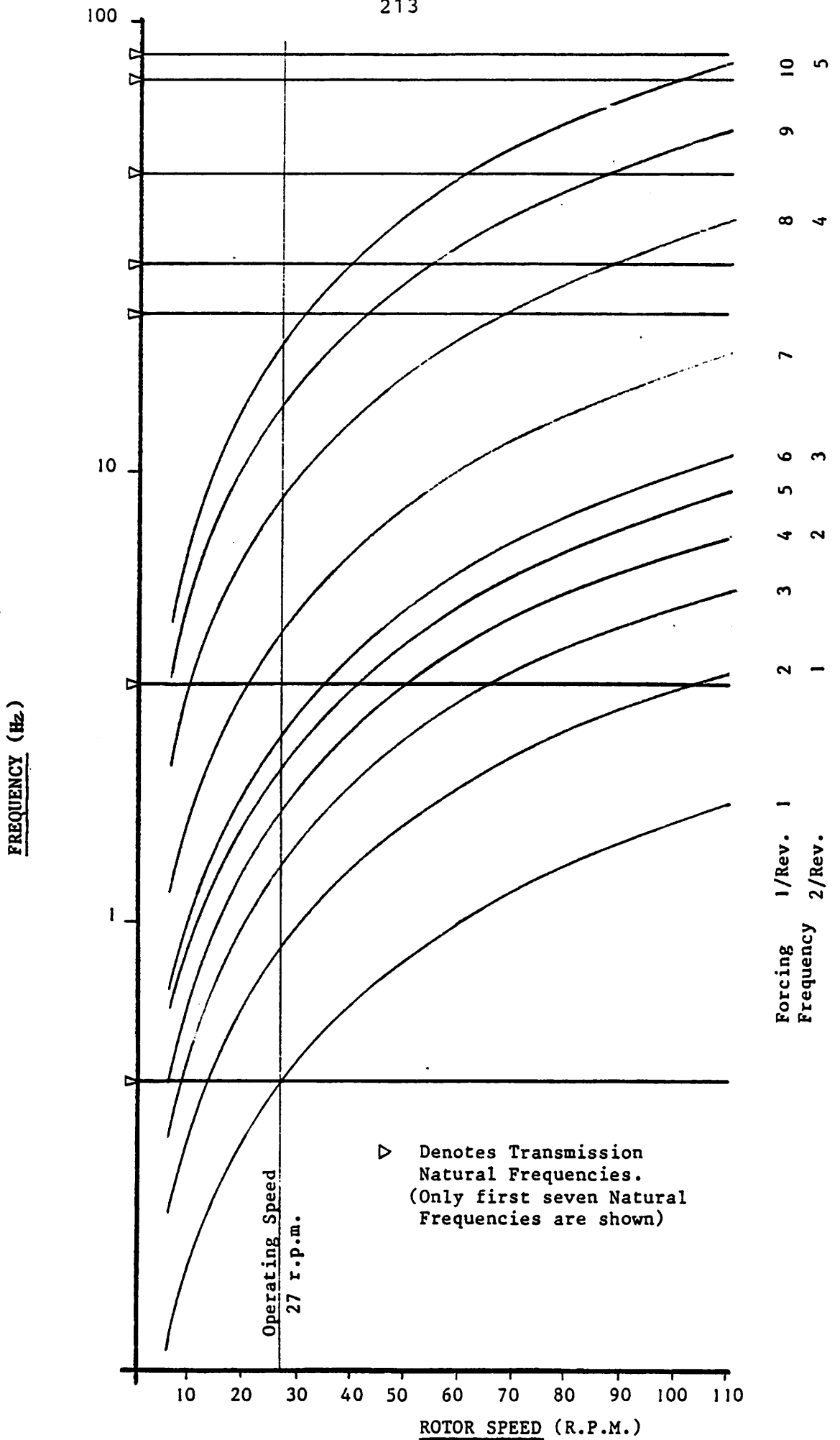
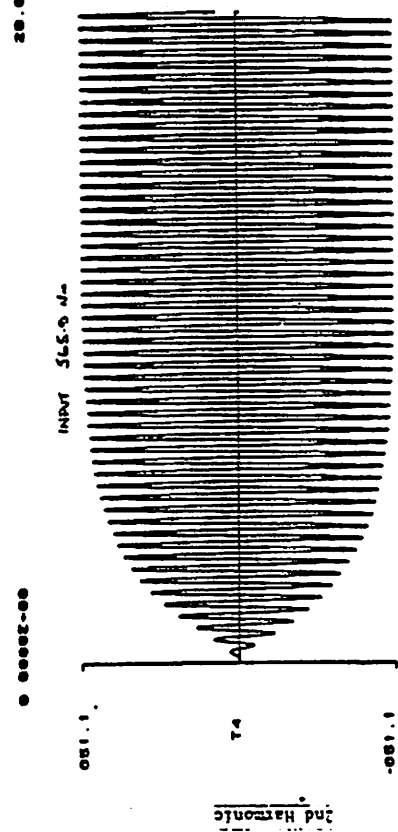
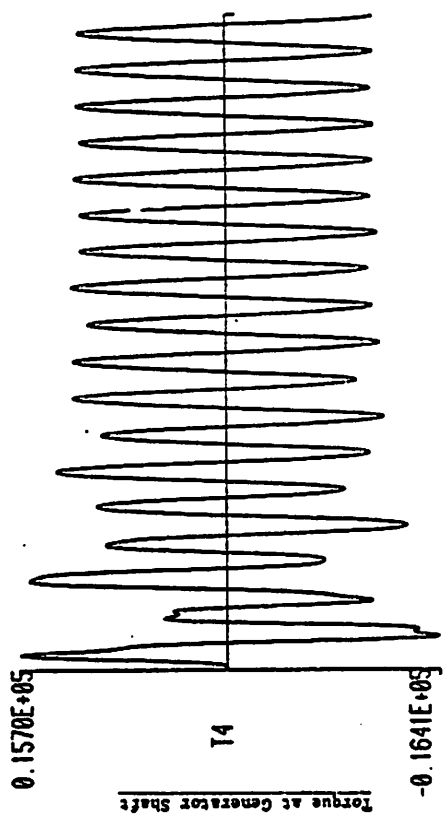
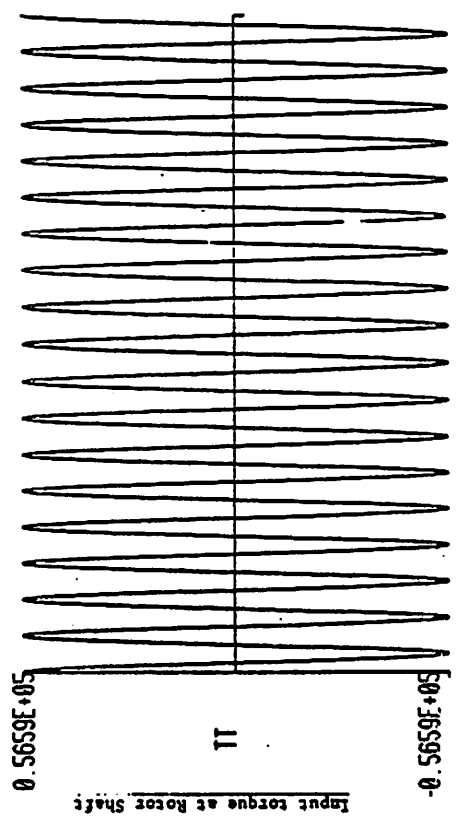
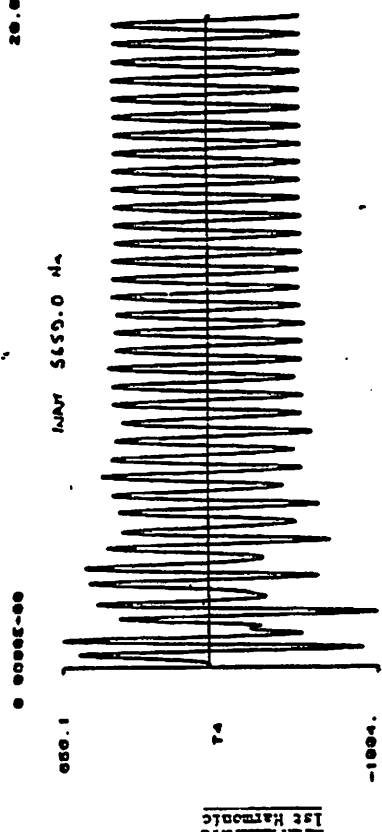
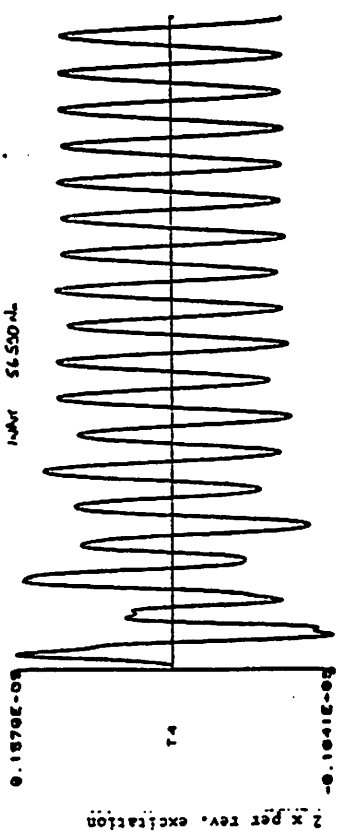

Fig.8 Spoke diagram showing natural and excitation

10.422 263 3.66 200 1.4  
 Stress & Flex. Analysis



0.0000E+00 20.00

Fig.9 Time history output showing torque variation at generator shaft

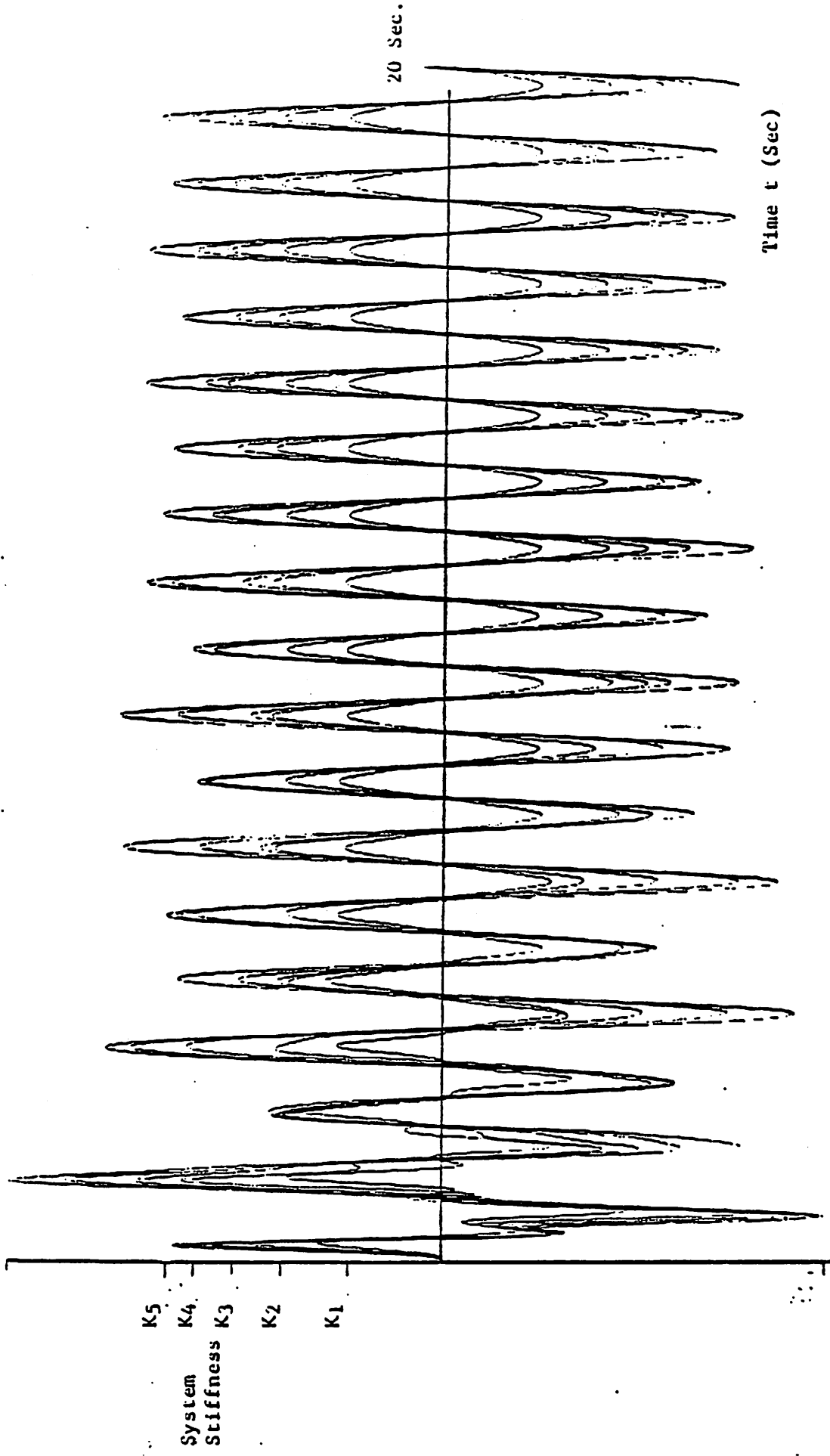
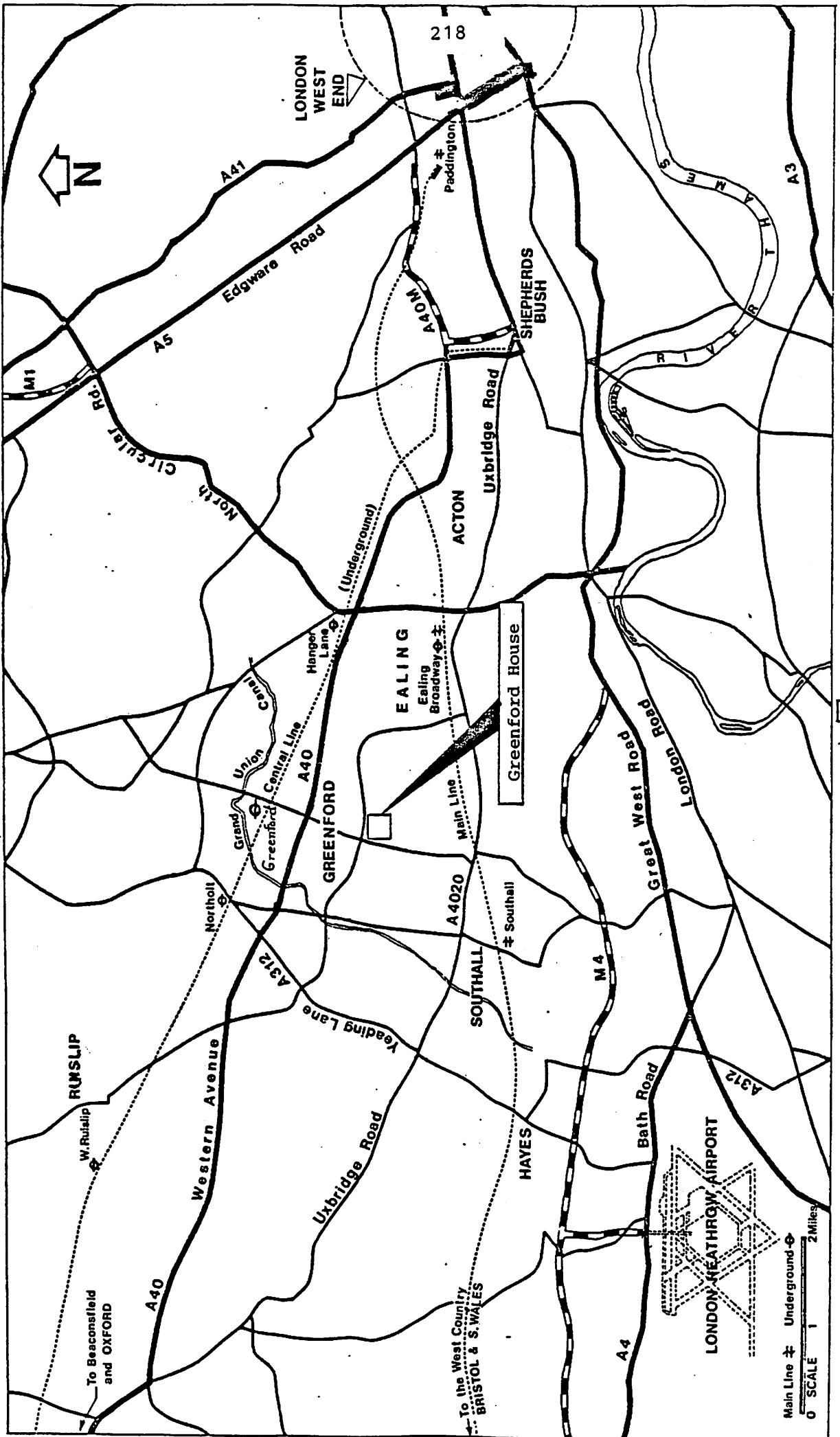

Figure 10 Variation of torque at generator for sinusoidal input torque at rotor shaft.

## LIST OF PARTICIPANTS

M B Anderson	Sir Robert McAlpine & Sons Limited, UK
K Braun	University Stuttgart, FRG
B Dahlroth	VAST, Sweden
I Ficenec	NEI Cranes Limited, UK
A D Garrad	Wind Energy Group, UK
U Hassan	Wind Energy Group, UK
I V Hau	MAN Neue Technologie, FRG
S Holt	Central Electricity Research Laboratories, UK
P Madsen	Risø, Denmark
K McAnulty	Energy Technology Support Unit Department of Energy, UK
D B McIver	W S Atkins, UK
D J Milborrow	Central Electricity Research Laboratories, UK
B Montgomerie	FFA, Sweden
I H O'Donnell	North of Scotland Hydro Electric Board, UK
B M Pedersen	TU Copenhagen, Denmark
P B Simpson	Wind Energy Group, UK
R Thresher	Oregon State University, USA
D A Thurgood	Wind Energy Group, UK
A Ulfvarson	Svenska Varv Vindenergi AB, Sweden



Wind Energy Group; 309 Rutlip Road, East Greenford, Middx. UB6 9BO

IEA - Implementing Agreement LS-WECS  
Previous Expert Meetings

1. Seminar on Structural Dynamics, Munich, October 12, 1978
2. Control of LS-WECS and Adaptation of Wind Electricity to the Network, Copenhagen, April 4, 1979
3. Data Acquisition and Analysis for LS-WECS, Blowing Rock, North Carolina, Sept. 26-27, 1979
4. Rotor Blade Technology with Special Respect to Fatigue Design Problems, Stockholm, April 21-22, 1980
5. Environmental and Safety Aspects of the Present LS WECS, Munich, September 25-26, 1980
6. Reliability and Maintenance Problems of LS WECS, Aalborg, April 29-30, 1981
7. Costings for Wind Turbines, Greenford, March 7-8, 1983